

Anhang / Annexe / Appendix

Verzeichnis / Table des matières / Contents

1	Übersicht / Disposition / Arrangement	A - 2
2	Verschleisteile / Pièces d'usure / Wearing parts	A - 16
3	Hydraulikschema / Schéma hydraulique / Hydraulic diagram	A - 78
4	Hydrostatik- und Schmierschema Schéma hydrostatique et lubrification Hydrostatic and lubrication diagram	A - 83
5	Pneumatikschema / Schéma pneumatique / Pneumatic diagram	A - 88
6	Kühlschema / Schéma de refroidissement / Coolant diagram	A - 101
7	Kühlschmiermittelschema Schéma de lubrifiant de refroidissement Coolant-lubricant diagram	A - 103
8	Schmierschema HF- Innenschleifspindel Schéma de lubrification broches de rectification intérieure H.F. Lubrication diagram HF internal grinding spindle	A - 110
9	Schmieranleitung / Instructions de graissage / Lubrication instructions	A - 115

I Übersicht / Disposition / Arrangement

Die in diesem Anhang enthaltenen Schemata beinhalten neben der Standardausrüstung auch sämtliche Optionen und müssen mit der effektiven Maschinenausrüstung nicht übereinstimmen. Soweit es sich um optionale Maschinenausrüstungen handelt sind diese in den Schemata mit Rahmen und entsprechender Ident.-Nr. gekennzeichnet. Die folgende Tabelle zeigt eine Übersicht der möglichen Optionen.

Les schémas de cette annexe contiennent en plus de l'équipement standard également de nombreuses options et peuvent ne pas concorder avec l'équipement effectif de la machine. Lorsqu'il s'agit d'équipements optionnels de la machine, ceux-ci sont contenus dans des schémas avec cadre et sont indiqués par le n° d'identification correspondant. Le tableau suivant présente un aperçu des options possibles.

The diagrams in this appendix show not only the standard equipment but also all optional extras. Consequently, they may differ from the actual machine as supplied. Where optional machine equipment is concerned, this is shown in the diagrams with a frame and is identified by the corresponding identity no. The following tables show an overview of possible optional extras.

	Bezeichnung der Option	Désignation de l'option	Designation of option
10210.01	DREHTEIL MIT MAN. INDEXIERUNG	PLATEAU D' INDEXATION MANUELLE	SWIVELLING SYSTEM WITH MANUALLY INDEXING
10220.01	DREHTEIL MIT AUTOM. INDEXIERUNG	PLATEAU D' INDEXATION AUTOMATIQUE	SWIVELLING SYSTEM WITH AUTOMATICALLY INDEXING
10230.01	B-ACHSE MIT DIREKTEM MESSSYSTEM	AXE B AVEC SYSTÈME DE MESURE DIRECT	B-AXIS WITH DIRECT GAUGE SYSTEM
10230.02	B-ACHSE MIT INDIREKTEM MESSSYSTEM	AXE B AVEC SYSTÈME DE MESURE INDIRECT	B-AXIS WITH INDIRECT GAUGE SYSTEM
10700.00	BETRIEBSEINHEIT FÜR EINE HJN-SPINDEL	UNITÉ DE FONCTIONNEMENT POUR UNE BROCHE HJN	OPERATING UNIT FOR A HJN SPINDLE
10710.00	BETRIEBSEINHEIT FÜR EINE MFV-SPINDEL	UNITÉ DE FONCTIONNEMENT POUR UNE BROCHE MFV	OPERATING UNIT FOR A MFV SPINDLE
10710.02	BETRIEBSEINHEIT FÜR ZWEI MFV-SPINDELN	UNITÉ DE FONCTIONNEMENT POUR DEUX BROCHES MFV	OPERATING UNIT FOR TWO MFV SPINDLES
10800.00	WERKSTÜCKSPINDELSTOCK STANDARD	POUPÉE PORTE-PIÈCE STANDARD	WORKHEAD STANDARD VERSION
10800.02	WERKSTÜCKSPINDELSTOCK STANDARD MIT ORIENTIERTEM SPINDELHALT	POUPÉE PORTE-PIÈCE STANDARD AVEC L' ARRÊT ORIENTÉ DE LA BROCHE PORTE-PIÈCE	WORKHEAD STANDARD VERSION WITH POSITIONED SPINDLE STOP
10800.04	WERKSTÜCKSPINDELSTOCK STANDARD MIT C-ACHSE	POUPÉE PORTE-PIÈCE STANDARD AVEC AXE C	WORKHEAD STANDARD VERSION WITH C-AXIS
10800.06	WSP STANDARD MIT ERHÖHTER ARBEITSGENAUIGKEIT	POUPÉE PORTE-PIÈCE STANDARD AVEC PRÉCISION DE TRAVAIL PLUS ÉLEVÉE	WORKHEAD STANDARD WITH INCREASED WORKING ACCURACY
10800.08	WSP STANDARD MIT ERHÖHTER ARBEITSGENAUIGKEIT UND ORIENTIERTEM SPINDELHALT	POUPÉE PORTE-PIÈCE STANDARD AVEC PRÉCISION DE TRAVAIL PLUS ÉLEVÉE ET ARRÊT ORIENTÉ DE LA BROCHE	WORKHEAD STANDARD WITH INCREASED WORKING ACCURACY AND POSITIONED SPINDLE STOP
10810.00	WERKSTÜCKSPINDELSTOCK VERSTÄRKT	POUPÉE PORTE-PIÈCE RENFORCÉE	REINFORCED WORKHEAD
10810.02	WERKSTÜCKSPINDELSTOCK VERSTÄRKT MIT ORIENTIERTEM SPINDELHALT	POUPÉE PORTE-PIÈCE RENFORCÉE, AVEC ARRÊT ORIENTÉ DE LA BROCHE	REINFORCED WORKHEAD WITH POSITIONED SPINDLE STOP
10810.04	WERKSTÜCKSPINDELSTOCK VERSTÄRKT MIT C-ACHSE	POUPÉE PORTE-PIÈCE RENFORCÉE, AVEC AXE C	REINFORCED WORKHEAD WITH C AXIS
10870.32	PNEUM. ENTLASTUNG WERKSTÜCKSPINDELSTOCK	ALLÈGEMENT PNEUMATIQUE POUPÉE PORTE-PIÈCE	WORKHEAD AIR CUSHION
10870.60	KÜHLSCHMIERMITTELZUFÜHRUNG DURCH WERKSTÜCKSPINDEL	ALIMENTATION DU LUBRIFIANT DE REFROIDISSEMENT PAR LA BROCHE PORTE-PIÈCE	COOLANT-LUBRICANT SUPPLY THROUGH WORKHEAD SPINDLE
10900.02	REITSTOCK KOMBINIERT MIT HAND- UND HYDRAULISCHEM RÜCKZUG	CONTRE-POUPÉE COMBINÉE AVEC UNE RÉTRACTION MANUELLE ET HYDRAULIQUE DE LA CONTRE-POINTE	TAILSTOCK COMBINED WITH MANUAL AND HYDRAULIC RETRACTION
10900.04	REITSTOCK KOMBINIERT MIT HAND- UND PNEUMATISCHEM RÜCKZUG	CONTRE-POUPÉE COMBINÉE AVEC UNE RÉTRACTION MANUELLE ET PNEUMATIQUE DE LA CONTRE-POINTE	TAILSTOCK COMBINED WITH MANUAL AND PNEUMATIC RETRACTION
10970.80	PNEUM. ENTLASTUNG REITSTOCK	ALLÈGEMENT PNEUMATIQUE CONTRE-POUPÉE	TAILSTOCK AIR CUSHION
11100.00	PNEUM. KRAFTSPANNENRICHTUNG	ALLÈGEMENT PNEUMATIQUE VÉRIN DE SERRAGE	POWER CLAMPING SYSTEM AIR CUSHION
11230.20	VORBEREITUNG HYDR. LUNETTE	PRÉPARATION DE LA LUNETTE HYDRAULIQUE	KIT OF CONNECTING PARTS HYDR. STEADY-REST
11300.00	ABRICHTGERÄT AM UNTERTISCH, RST-SEITIG	DISPOSITIF À DRESSER MONTÉ À LA TABLE INFÉRIEURE, CÔTE CONTRE-POUPÉE	DRESSING DEVICE ON THE LOWER TABLE, TAILSTOCK-SIDED
11300.02	ABRICHTGERÄT AM UNTERTISCH, WSP-SEITIG	DISPOSITIF À DRESSER MONTÉ À LA TABLE INFÉRIEURE, CÔTE POUPÉE PORTE-PIÈCE	DRESSING DEVICE ON THE LOWER TABLE, WORKHEAD-SIDED
11310.00	ABRICHTGERÄT AUF DEM OBERTISCH	DISPOSITIF À DRESSER MONTÉ SUR LA TABLE SUPÉRIEURE	DRESSING DEVICE ON THE UPPER TABLE
11330.00	CBN-ABRICHTROLLE	MOLETTE DE DRESSAGE CBN	CBN DRESSING ROLL

	Bezeichnung der Option	Désignation de l'option	Designation of option
I 1340.00	HF-ABRICHTGERÄT AUF DEM OBERTISCH	DISPOSITIF À DRESSER HF MONTÉ SUR LA TABLE SUPÉRIEURE	HF DRESSING DEVICE ON THE UPPER TABLE
I 1400.00	AKTIVE LÄNGSPOSITIONIERUNG KEL-POS MOVOMATIC	SYSTÈME DE POSITIONNEMENT ACTIF KEL-POS MOVOMATIC	ACTIVE FLAGGING DEVICE KEL-POS MOVOMATIC
I 1400.20	AKTIVE LÄNGSPOSITIONIERUNG KEL-POS MARPOSS	SYSTÈME DE POSITIONNEMENT ACTIF KEL-POS MARPOSS	ACTIVE FLAGGING DEVICE KEL-POS MARPOSS
I 1430.02	MESSSTEUERUNG MOVOMATIC DP200	SYSTÈME D'AUTO-CALIBRAGE MOVOMATIC DP200	IN-PROCESS GAUGE SYSTEM MOVOMATIC DP200
I 1430.04	MESSSTEUERUNG MOVOMATIC DM200	SYSTÈME D'AUTO-CALIBRAGE MOVOMATIC DM200	IN-PROCESS GAUGE SYSTEM MOVOMATIC DM200
I 1430.06	MESSSTEUERUNG MOVOMATIC DM200+	SYSTÈME D'AUTO-CALIBRAGE MOVOMATIC DM200+	IN-PROCESS GAUGE SYSTEM MOVOMATIC DM200+
I 1430.08	MESSSTEUERUNG MOVOMATIC DU200	SYSTÈME D'AUTO-CALIBRAGE MOVOMATIC DU200	IN-PROCESS GAUGE SYSTEM MOVOMATIC DU200
I 1430.10	MESSSTEUERUNG MOVOMATIC DU200+	SYSTÈME D'AUTO-CALIBRAGE MOVOMATIC DU200+	IN-PROCESS GAUGE SYSTEM MOVOMATIC DU200+
I 1430.42	MESSSTEUERUNG MARPOSS P50	SYSTÈME D'AUTO-CALIBRAGE MARPOSS P50	IN-PROCESS GAUGE SYSTEM MARPOSS P50
I 1430.44	MESSSTEUERUNG MARPOSS S20	SYSTÈME D'AUTO-CALIBRAGE MARPOSS S20	IN-PROCESS GAUGE SYSTEM MARPOSS S20
I 1430.46	MESSSTEUERUNG MARPOSS S30	SYSTÈME D'AUTO-CALIBRAGE MARPOSS S30	IN-PROCESS GAUGE SYSTEM MARPOSS S30
I 1430.48	MESSSTEUERUNG MARPOSS S31	SYSTÈME D'AUTO-CALIBRAGE MARPOSS S31	IN-PROCESS GAUGE SYSTEM MARPOSS S31
I 1500.00	PAPIERBANDFILTER SPB 4	FILTRE À RUBAN DE PAPIER SPB 4	PAPER TAPE FILTER SPB 4
I 1500.10	PAPIERBANDFILTER SPB 5	FILTRE À RUBAN DE PAPIER SPB 5	PAPER TAPE FILTER SPB 5
I 1510.00	KOMBIFILTER SPB 4/SAMG5	FILTRE COMBINÉ SPB 4/SAMG5	COMBINED FILTER SPB 4/SAMG5
I 1510.10	KOMBIFILTER SPB 5/SAMG5	FILTRE COMBINÉ SPB 5/SAMG5	COMBINED FILTER SPB 5/SAMG5
I 1520.00	ENDLOS-BANDFILTER STE-5	FILTRE DE LA BANDE SANS FIN STE-5	ENDLESS BAND FILTER STE-5
I 1540.60	VORBEREITUNG ANSCHL. ZENTRALE KÜHLSCHMIERMITTELANLAGE, 3BAR	JEU DE PIÈCE DE CONNEX., GROUPE CENTRALE POUR LUBRIFIANT DE REFROIDISSEMENT, 3BAR	KIT OF CONNECT. PARTS, CENTRAL COOLANT-LUBRICANT SYSTEM, 3BAR
I 1540.70	VORBEREITUNG ANSCHL. ZENTRALE KÜHLMITTELANLAGE, 10BAR	JEU DE PIÈCE DE CONNEX., GROUPE CENTRALE POUR LUBRIFIANT DE REFROIDISSEMENT, 10BAR	KIT OF CONNECT. PARTS, CENTRAL COOLANT-LUBRICANT SYSTEM, 10BAR
I 1560.00	KÜHLSCHMIERMITTELABSCHALTUNG FÜR TISCHGERÄTE	INTERRUPTION DU FLUIDE DU LUBRIFIANT DE REFROIDISSEMENT POUR LES APPAREILS DE TABLE	COOLANT-LUBRICANT SHUT-OFF DEVICE FOR TABLE DEVICES
I 1700.01	WARTUNGSEINHEIT FÜR PNEUM. ZUSATZFUNKTIONEN	UNITÉ D'ENTRETIEN POUR FONCTIONS PNEUMATIQUES SUPPLÉMENTAIRES	MAINTENANCE UNIT FOR PNEUMATICAL ADDITIONAL FUNCTIONS

Universal-Schleifköpfe / Poupées porte-meule Universelles / Universal wheelheads

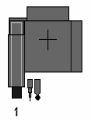
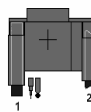
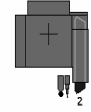
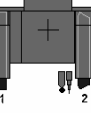
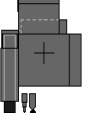
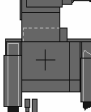
Bezeichn. / Désign. / Design. Schwenkbereich / Plage de pivotement / Swiveling range	Abbildung / Illustration Illustration	Max. Abmessungen Werkzeuge Dimensions max. d'outils Max. dimensions of the tools			
		1	2	3	4
R I +30° / -210°		T1 ø500x80 ø20"x3"	-	-	-
R I-2 +30° / -210°		T1 ø500x80 ø20"x3"	T2 ø400x63 ø16"x2.5"	-	-
RS 2 +30° / -210°		T2 ø500x80 ø20"x3"	-	-	-
RS I-2 +30° / -210°		T1 ø500x80 ø20"x3"	T2 ø500x80 ø20"x3"	-	-
UR I-3 +30° / -210°		T1 ø500x80 ø20"x3"	T3 HJN ø80 ø3 5/32" oder/ou/or HF ø120 ø4 23/32"	-	-
UR I-2-3 +30° / -210°		T1 ø500x80 ø20"x3"	T2 ø400x63 ø16"x2.5"	T3 HJN ø80 ø3 5/32" oder/ou/or HF ø120 ø4 23/32"	-

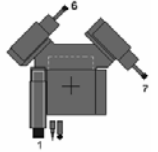
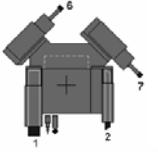
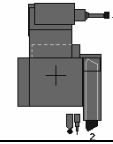
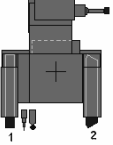
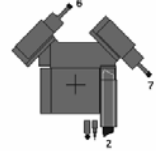
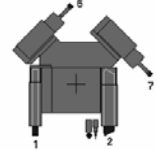
Bezeichn. / Désign. / Design. Schwenkbereich / Plage de pivotement / Swiveling range	Abbildung / Illustration Illustration	Max. Abmessungen Werkzeuge Dimensions max. d'outils Max. dimensions of the tools			
		1	2	3	4
UR I-6-7 +10° / -230°		T1 ø500x80 ø20"x3"	T6 HF ø120 ø4 23/32"	T7 HF ø120 ø4 23/32"	-
UR I-2-6-7 +10° / -230°		T1 ø500x80 ø20"x3"	T2 ø400x63 ø16"x2.5"	T6 HF ø120 ø4 23/32"	T7 HF ø120 ø4 23/32"
URS 2-3 +30° / -210°		T2 ø500x80 ø20"x3"	T3 HJN ø80 ø3 5/32" oder/ou/or HF ø120 ø4 23/32"	-	-
URS I-2-3 +30° / -210°		T1 ø500x63 ø20"x2.5"	T2 ø500x80 ø20"x3"	T3 HJN ø80 ø3 5/32" oder/ou/or HF ø120 ø4 23/32"	-
URS 2-6-7 +10° / -230°		T2 ø500x80 ø20"x3"	T6 HF ø120 ø4 23/32"	T7 HF ø120 ø4 23/32"	-
URS I-2-6-7 +10° / -230°		T1 ø500x63 ø20"x2.5"	T2 ø500x80 ø20"x3"	T6 HF ø120 ø4 23/32"	T7 HF ø120 ø4 23/32"

Diagonal-Schleifköpfe / Poupées porte-meule Diagonal / Diagonal wheelheads

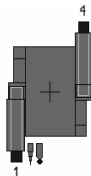
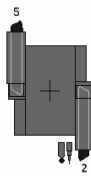
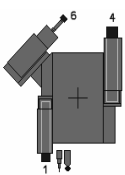
Bezeichn./Désign./Design. Schwenkbereich/Plage de pivotement/Swiveling range	Abbildung/Illustration Illustration	Max. Abmessungen Werkzeuge Dimensions max. d'outils Max. dimensions of the tools			
		1	2	3	4
2R I-4 +30° / -210°		T1 ø500x80 ø20"x3"	T4 ø500x80 ø20"x3"	-	-
2RS 2-5 +10° / -230°		T2 ø500x80 ø20"x3"	T5 ø500x80 ø20"x3"	-	-
2RU I-4-6 +10° / -230°		T1 ø400x63 ø16"x2.5"	T4 ø500x80 ø20"x3"	T6 HF ø120 ø4 23/32"	-

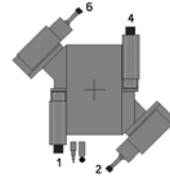
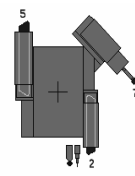
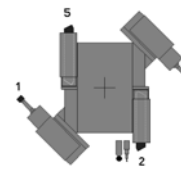
Bezeichn./Désign./Design. Schwenkbereich/Plage de pivotement/Swiveling range	Abbildung/Illustration Illustration	Max. Abmessungen Werkzeuge Dimensions max. d'outils Max. dimensions of the tools			
		1	2	3	4
2RU I-2-4-6 +10° / -230°		T1 ø400x63 ø16"x2.5"	T2 HF ø120 ø4 23/32"	T4 ø400x63 ø16"x2.5"	T6 HF ø120 ø4 23/32"
2RSU 2-5-7 +10° / -230°		T2 ø500x80 ø20"x3"	T5 ø400x63 ø16"x2.5"	T7 HF ø120 ø4 23/32"	-
2RSU I-2-5-7 +50° / -230°		T1 HF ø120 ø4 23/32"	T2 ø400x63 ø16"x2.5"	T5 ø400x63 ø16"x2.5"	T7 HF ø120 ø4 23/32"

Tandem-Schleifköpfe / Poupées porte-meule Tandem / Tandem wheelheads

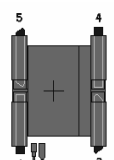
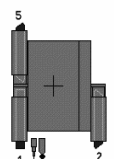
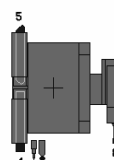
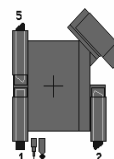
Bezeichn. / Désign. / Design. Schwenkbereich / Plage de pivotement / Swiveling range	Abbildung / Illustration Illustration	Max. Abmessungen Werkzeuge Dimensions max. d'outils Max. dimensions of the tools			
		1	2	3	4
R-RS I-5 +10° / -230°		T1 ø400x63 ø16"x2.5"	T5 ø400x63 ø16"x2.5"	-	-
R-RS I-2-4-5 +10° / -230°		T1 ø400x63 ø16"x2.5"	T2 ø400x63 ø16"x2.5"	T4 ø400x63 ø16"x2.5"	T5 ø400x63 ø16"x2.5"
R-RS I-2-5 +10° / -230°		T1 ø400x63 ø16"x2.5"	T2 ø400x63 ø16"x2.5"	T5 ø400x63 ø16"x2.5"	-
UR-RS I-5-8 +10° / -230°		T1 ø400x63 ø16"x2.5"	T5 ø400x63 ø16"x2.5"	T8 HF ø120 ø4 23/32"	-
UR-RS I-2-5-7 +10° / -230°		T1 ø400x63 ø16"x2.5"	T2 ø400x63 ø16"x2.5"	T5 ø400x63 ø16"x2.5"	T7 HF ø120 ø4 23/32"

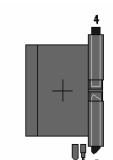
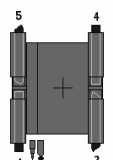
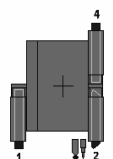
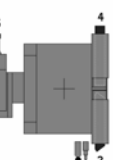
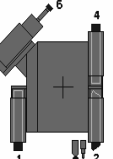
Bezeichn. / Désign. / Design. Schwenkbereich / Plage de pivotement / Swiveling range	Abbildung / Illustration Illustration	Max. Abmessungen Werkzeuge Dimensions max. d'outils Max. dimensions of the tools			
		1	2	3	4
RS-R 2-4 +10° / -230°		T2 ø400x63 ø16"x2.5"	T4 ø400x63 ø16"x2.5"	-	-
RS-R I-2-4-5 +10° / -230°		T1 ø400x63 ø16"x2.5"	T2 ø400x63 ø16"x2.5"	T4 ø400x63 ø16"x2.5"	T5 ø400x63 ø16"x2.5"
RS-R I-2-4 +10° / -230°		T1 ø400x63 ø16"x2.5"	T2 ø400x63 ø16"x2.5"	T4 ø400x63 ø16"x2.5"	-
URS-R 2-4-5 +190° / -50°		T2 ø400x63 ø16"x2.5"	T4 ø400x63 ø16"x2.5"	T5 HF ø120 ø4 23/32"	-
URS-R I-2-4-6 +10° / -230°		T1 ø400x63 ø16"x2.5"	T2 ø400x63 ø16"x2.5"	T4 ø400x63 ø16"x2.5"	T6 HF ø120 ø4 23/32"

Steuerung / Commande / Control unit

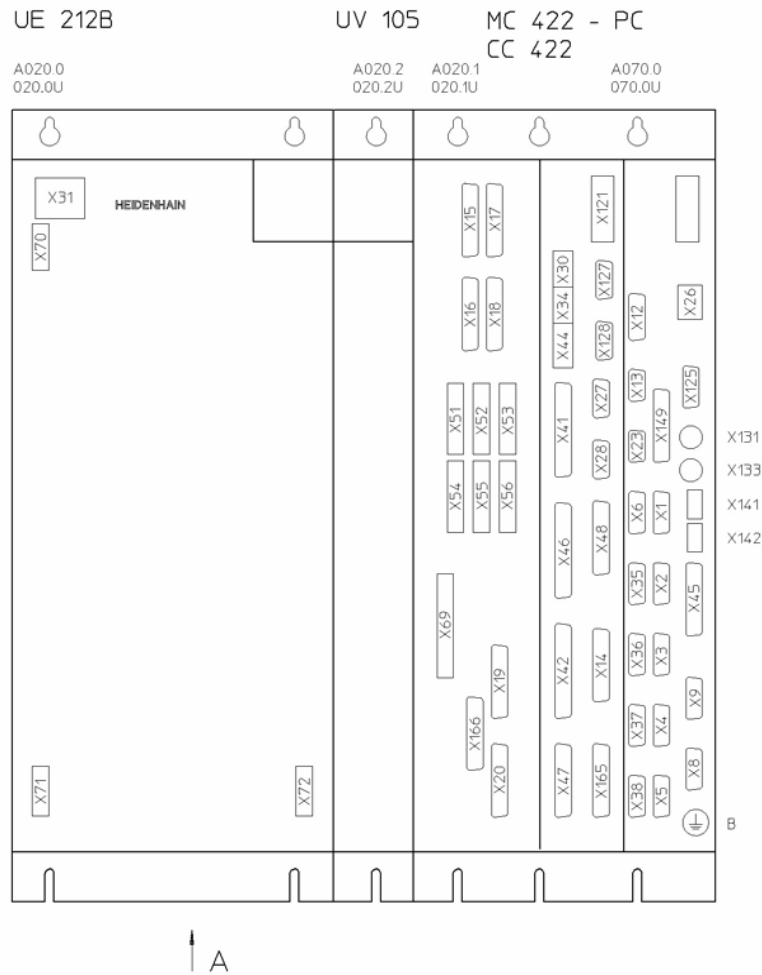

Ansicht A
 View A
 Projection A

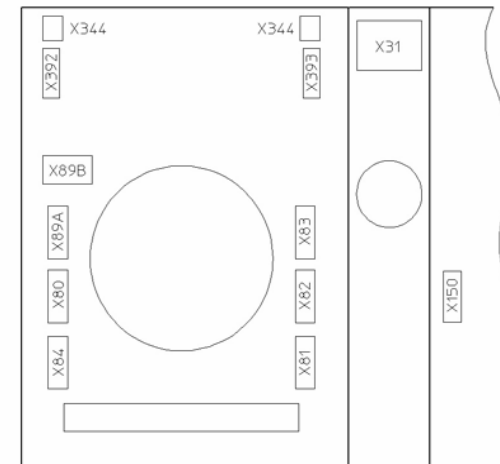

Panel / Panneau / Panel

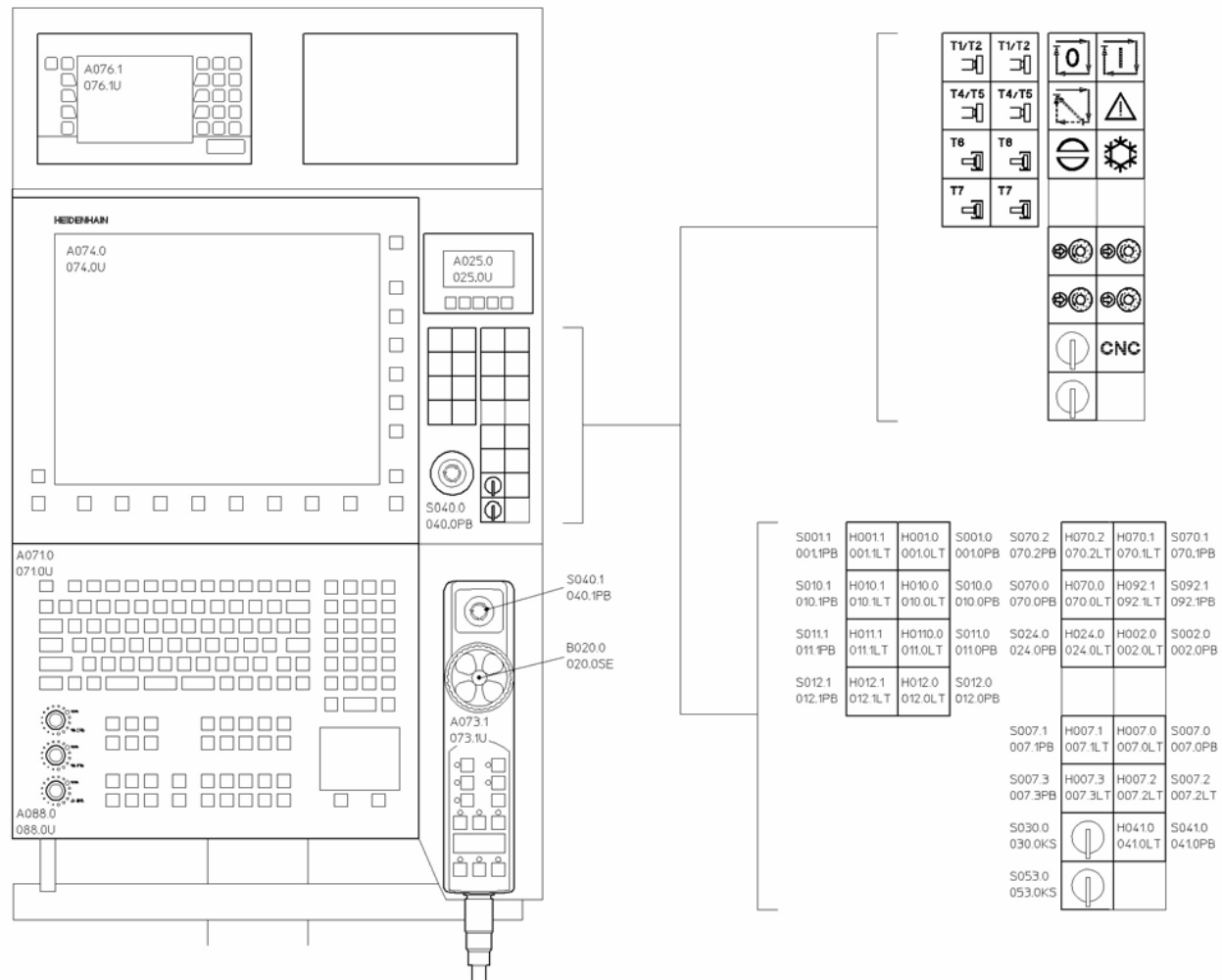

293323-2/6

Elektroschrank / Armoire électrique / Electric cubicle

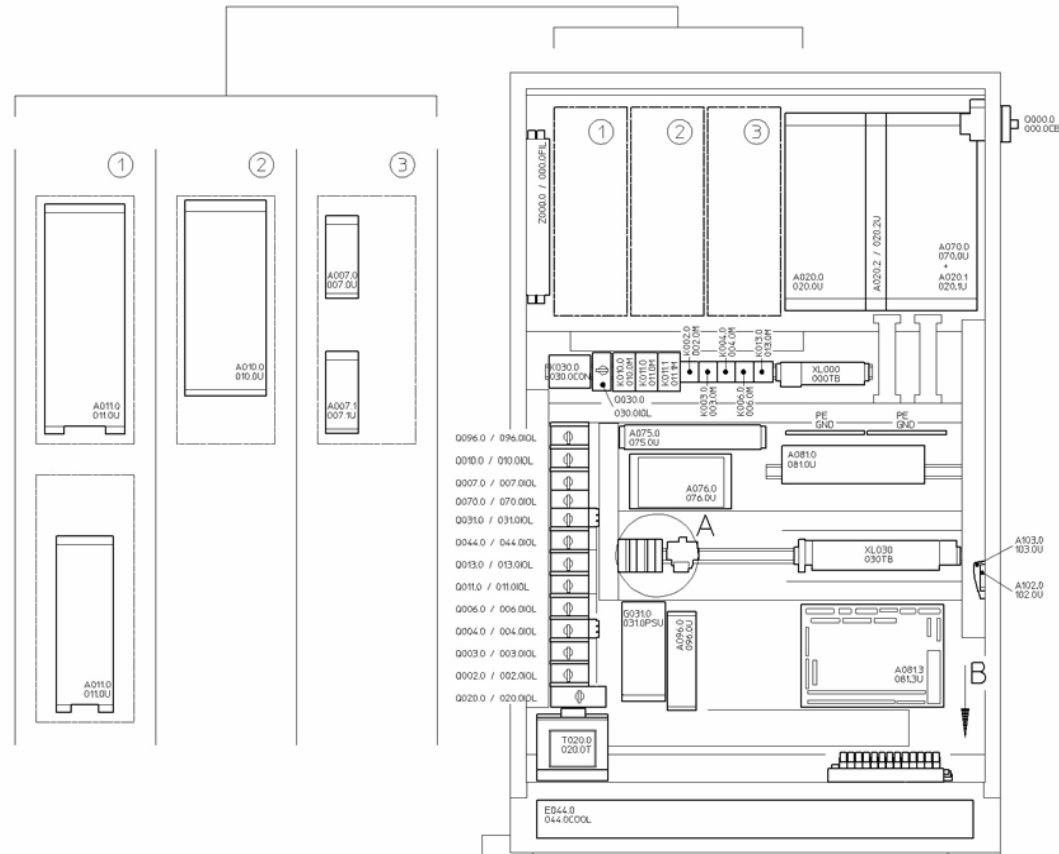

Ansicht A

View A
 Projection A

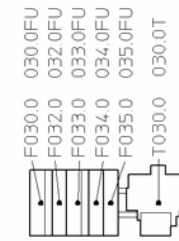

Ansicht B

View B
 Projection B

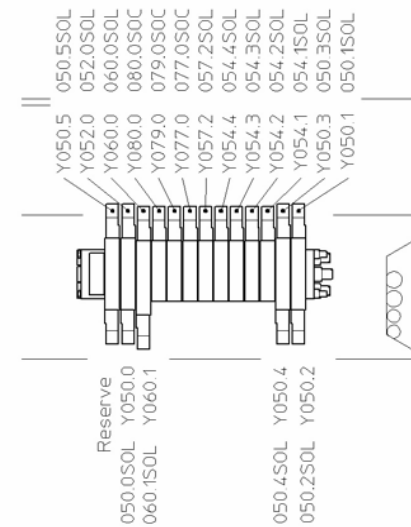

293323-3/6

Maschine / Machine / Machine

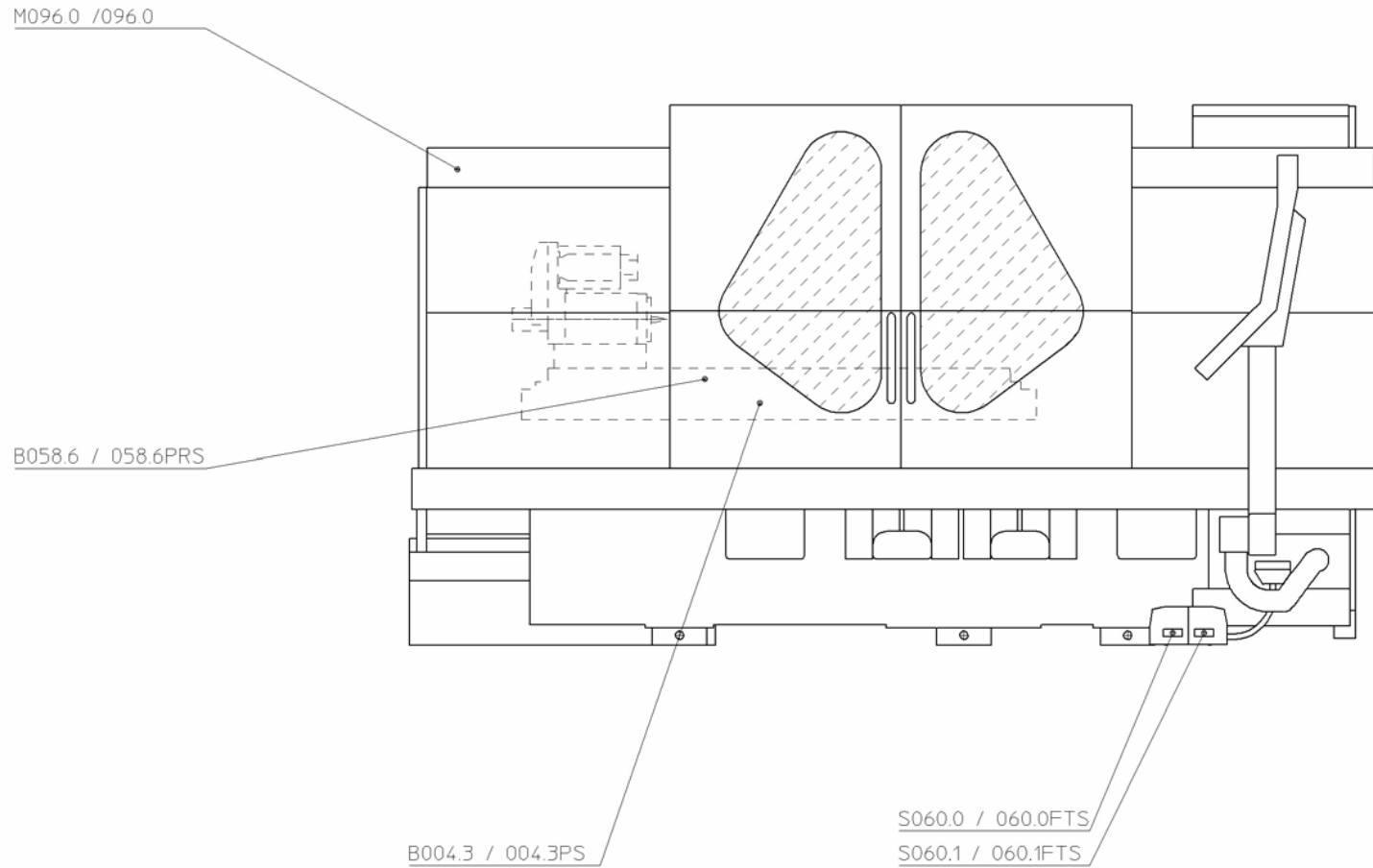

293323-4/6

Maschine / Machine / Machine

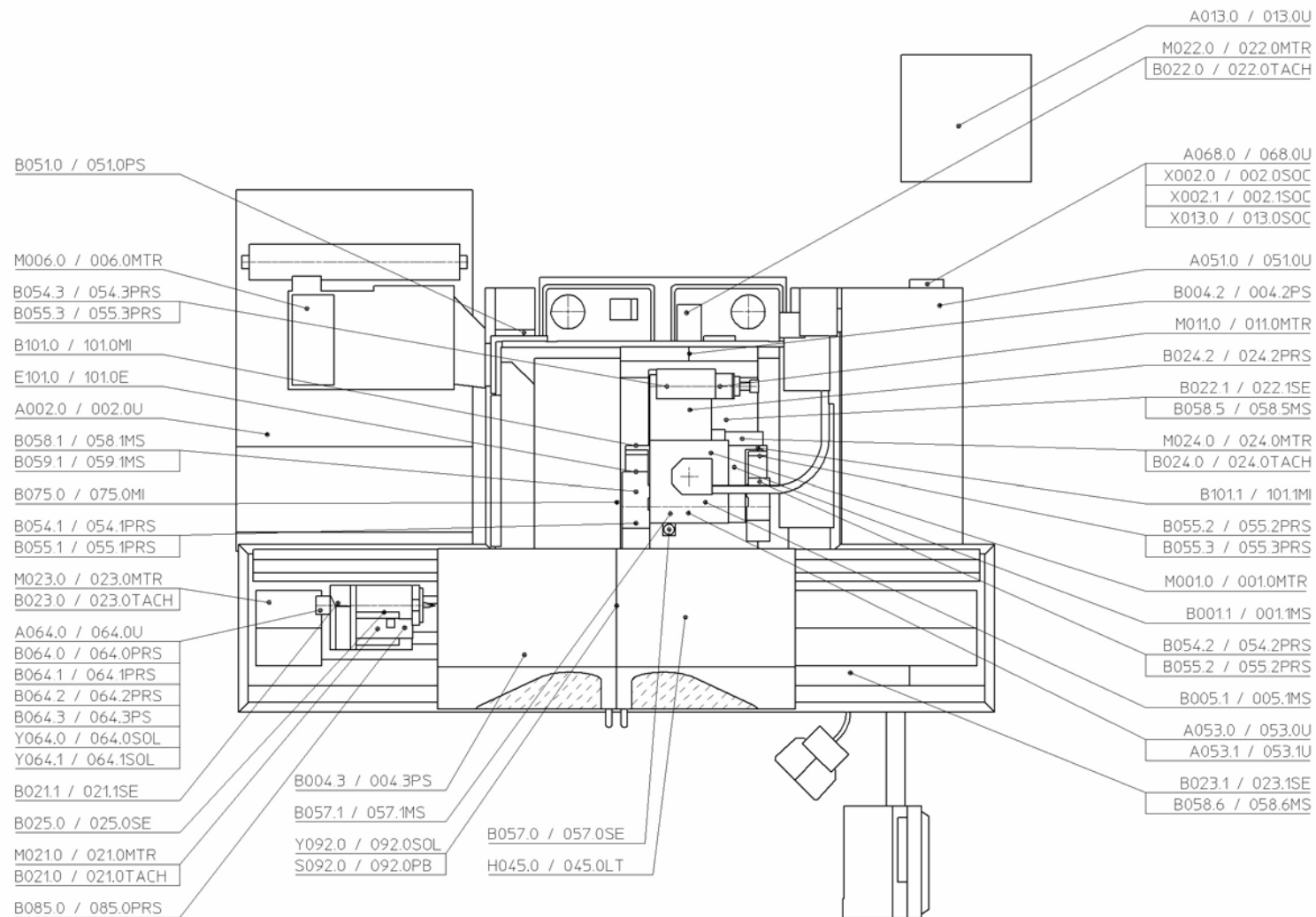

293323-5/6

Energieversorgung / Power supply / Alimentation en énergie

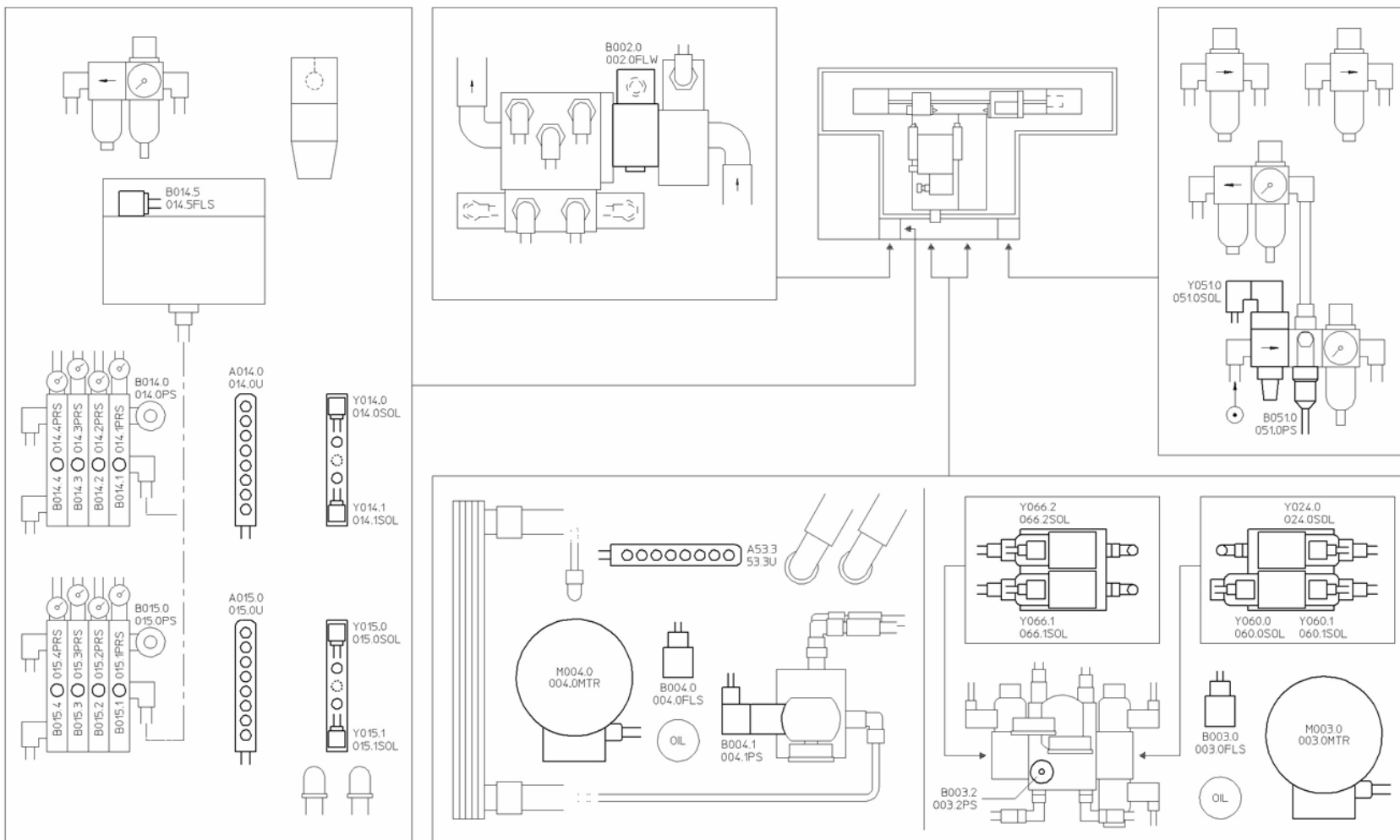

293323-6/6

Hardware Kabel Heidenhain / Hardware câble Heidenhain / Hardware cable Heidenhain

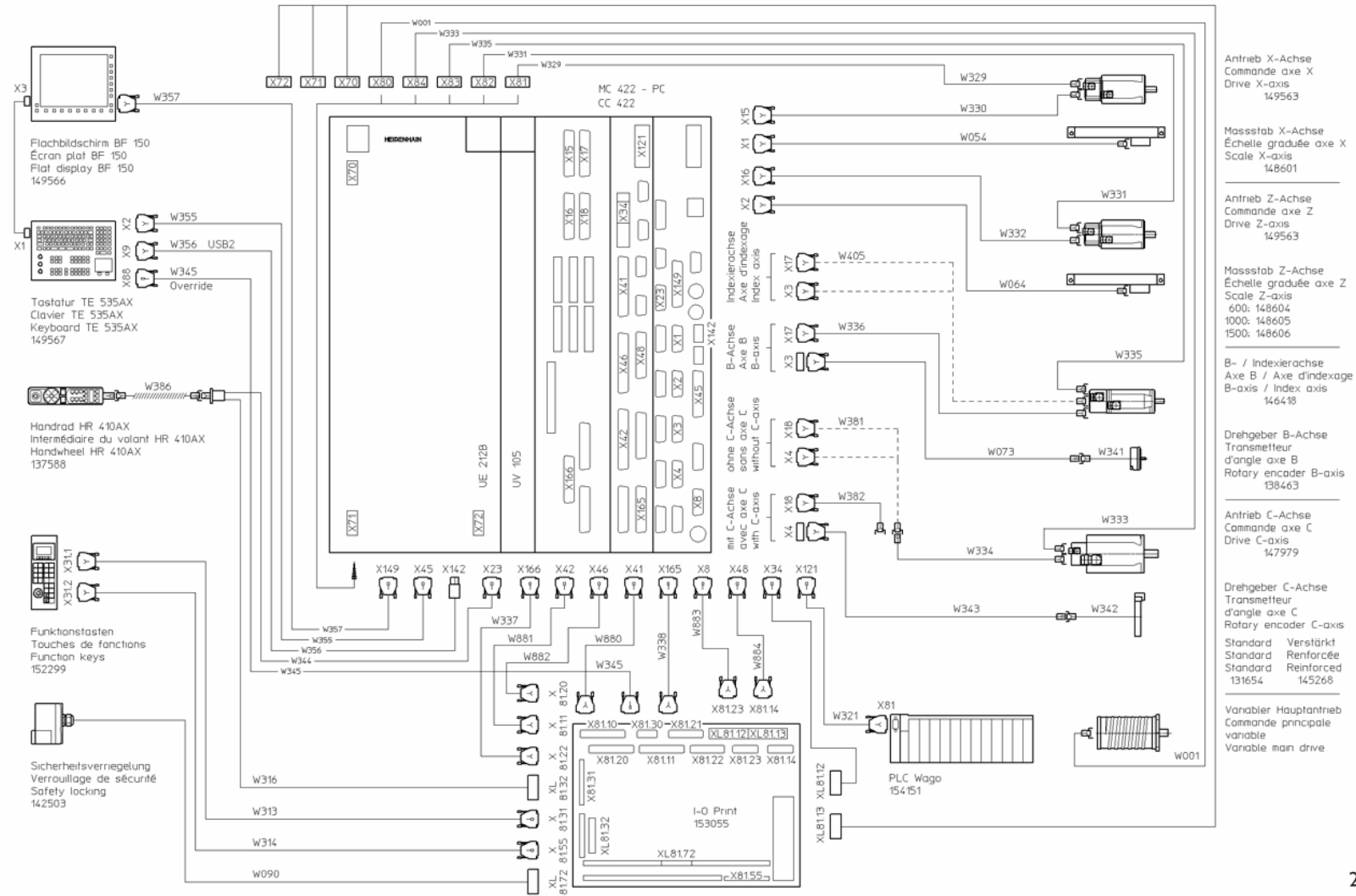

293326

Hardware Kabel Marposs / Hardware câble Marposs / Hardware cable Marposs

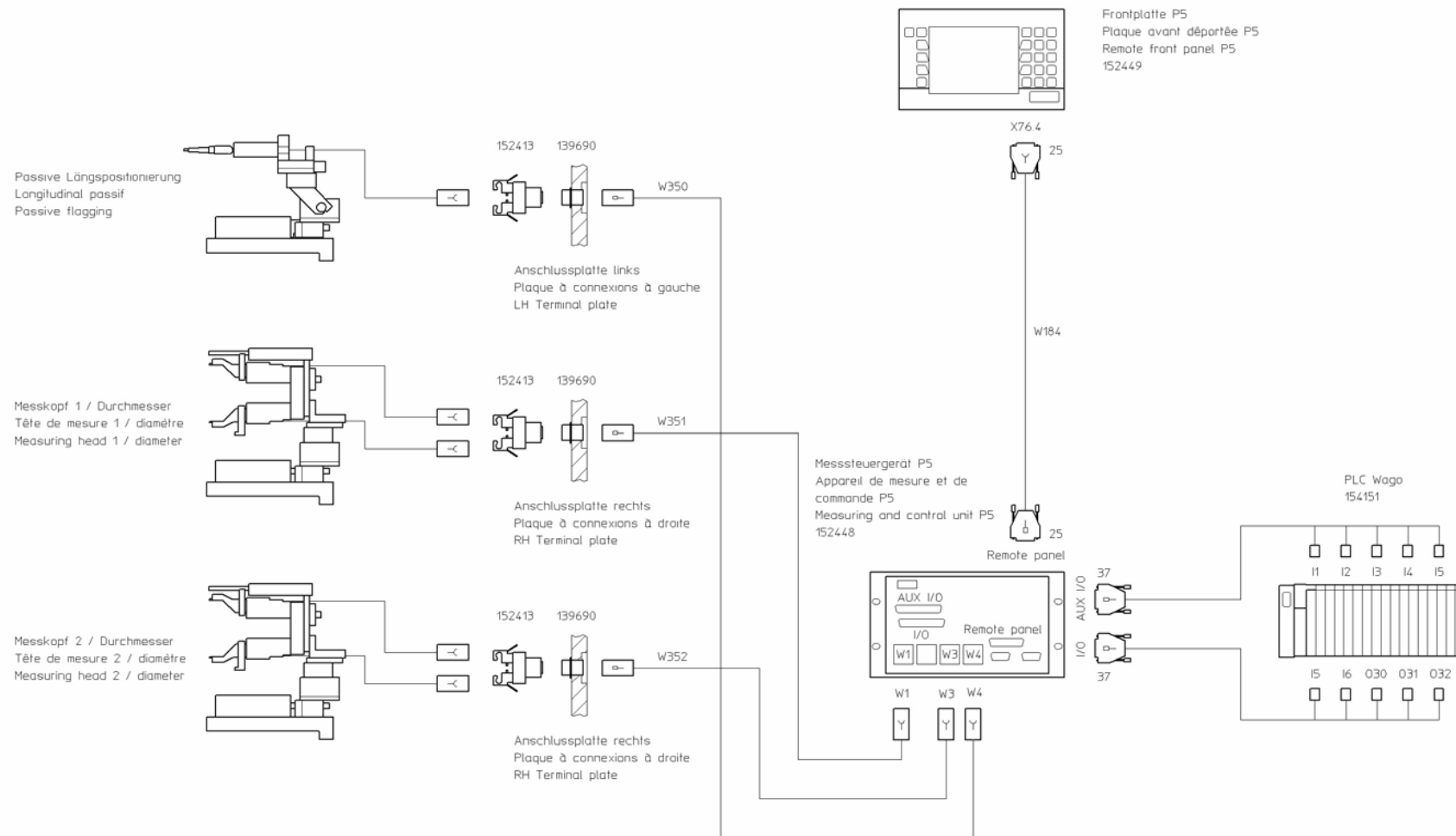

293330-1/2

Hardware Kabel Movomatic / Hardware câble Movomatic / Hardware cable Movomatic

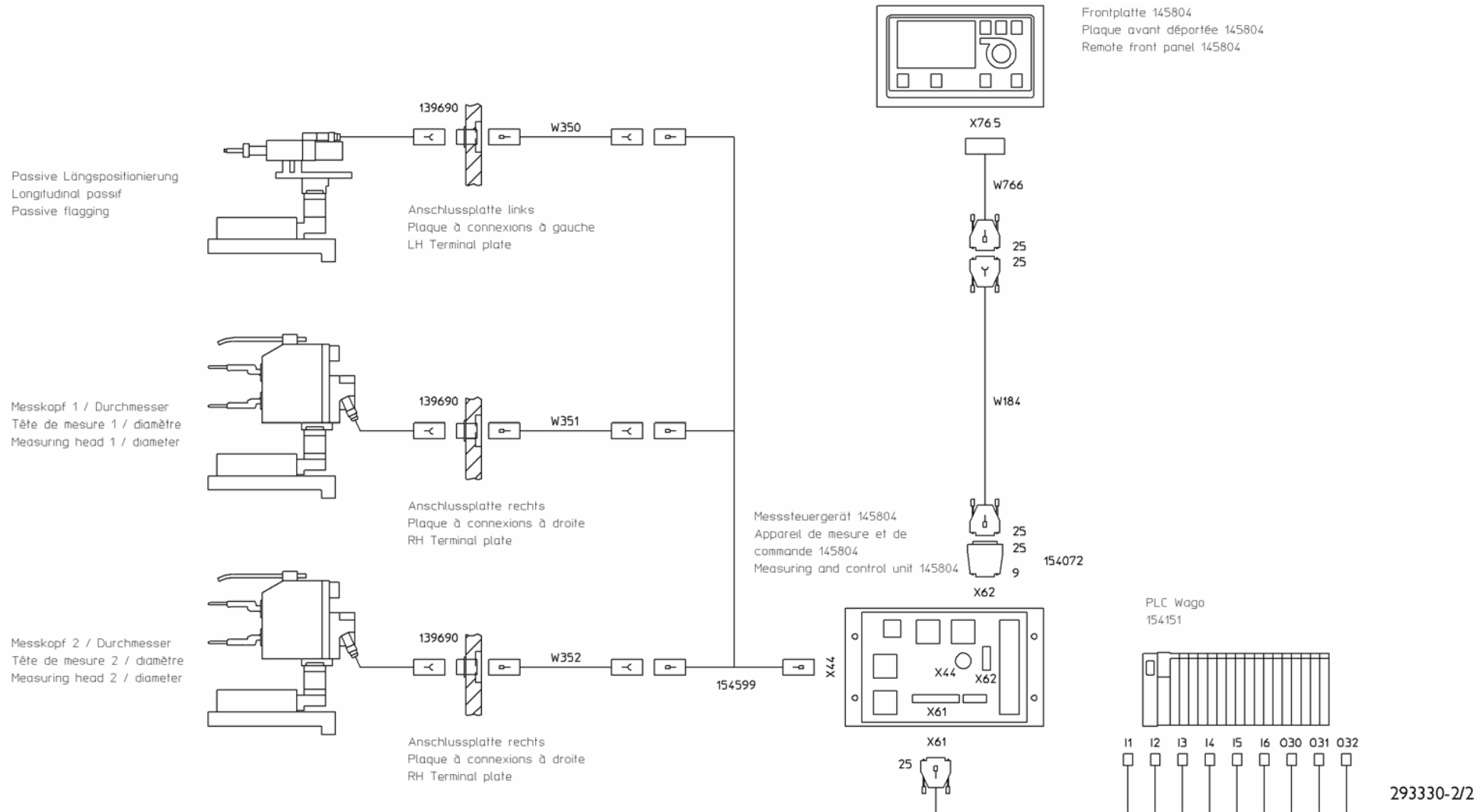

2 Verschleissteile / Pièces d'usure / Wearing parts

Position Rep. Item	Bezeichnung	Désignation	Designation of part	Lieferant Fournisseur Supplier	Bestell-Nr. Référence Order no.	Ident.-Nr. No. d'ident. ID-no.
042394	STERNGRIFF	POIGNÉE	STAR HANDLE		M8 / 40X30	042394
042396	STERNGRIFF	POIGNÉE	STAR HANDLE			042396
060885	KUGELHAHN	ROBINET D'ARROSAGE	BALL VALVE		G1/4"	060885
100562	DRUCKFEDER	RESSORT DE PRESSION	PRESSURE SPRING		0.4X4.8X10	100562
100601	DRUCKFEDER	RESSORT DE PRESSION	PRESSURE SPRING		1.6X8X21.7	100601
100607	DRUCKFEDER	RESSORT DE PRESSION	PRESSURE SPRING		1.7X15.2X55	100607
100619	DRUCKFEDER	RESSORT DE PRESSION	PRESSURE SPRING		4.0 X29X237	100619
100816	O-RING	JOINT TORIQUE	TORIDAL SEALING RING		70X2.5	100816
100863	SCHUTZSTOPFEN	BOUCHON DE PROTECTION	PROTECTION STOPPER		TL-4-105	100863
100876	O-RING	JOINT TORIQUE	TORIDAL SEALING RING		5X1.5	100876
100877	O-RING	JOINT TORIQUE	TORIDAL SEALING RING		5X2.5	100877
100878	O-RING	JOINT TORIQUE	TORIDAL SEALING RING		6X1.5	100878
100881	O-RING	JOINT TORIQUE	TORIDAL SEALING RING		8X2	100881
100885	O-RING	JOINT TORIQUE	TORIDAL SEALING RING		11X2.0	100885
100886	O-RING	JOINT TORIQUE	TORIDAL SEALING RING		12X2.0	100886
100888	O-RING	JOINT TORIQUE	TORIDAL SEALING RING		14X2.0	100888
100889	O-RING	JOINT TORIQUE	TORIDAL SEALING RING		14X3.0	100889
100902	O-RING	JOINT TORIQUE	TORIDAL SEALING RING		22X1.5	100902
100908	O-RING	JOINT TORIQUE	TORIDAL SEALING RING		25X2.5	100908
100909	O-RING	JOINT TORIQUE	TORIDAL SEALING RING		26X2.0	100909
100921	O-RING	JOINT TORIQUE	TORIDAL SEALING RING		45X2.0	100921
100922	O-RING	JOINT TORIQUE	TORIDAL SEALING RING		45X3.5	100922
100929	O-RING	JOINT TORIQUE	TORIDAL SEALING RING		65X3.0	100929
100931	O-RING	JOINT TORIQUE	TORIDAL SEALING RING		70X2.0	100931
102853	O-RING	JOINT TORIQUE	TORIDAL SEALING RING		17X2	102853
102978	KLEMMRING	BAGUE DE SERRAGE	CLAMPING RING			102978
103166	KEGELROLLENLAGER	ROULEMENT A GALETS CONIQUES	TAPER ROLLER BEARINGS		124070/124112XP	103166
103169	A-RING	BAGUE EXTÉRIEURE	OUTER-RING		11-P5	103169
103858	BUNDMUTTER	ECROU A EMBASE	FLANGED NUT			103858
104511	BACKEN	MORS	JAWS			104511
104514	GEWINDESPINDEL	BROCHE FILETÉE	ADJUSTING BOLT			104514
104515	GEWINDESPINDEL	BROCHE FILETÉE	ADJUSTING BOLT			104515
104583	BACKEN	MORS	JAWS			104583
105102	V-RING	JOINT TRAPÉZOÏDAL	V-SEALING RING		V-85A	105102

Position Rep. Item	Bezeichnung	Désignation	Designation of part	Lieferant Fournisseur Supplier	Bestell-Nr. Référence Order no.	Ident.-Nr. No. d'ident. ID-no.
I05108	V-RING	JOINT TRAPÉZOÏDAL	V-SEALING RING		V-145	I05108
I05110	V-RING	JOINT TRAPÉZOÏDAL	V-SEALING RING		V-65A	I05110
I05205	AXIAL-NADELKÄFIG	CAGE É AIGUILLES AXIAL	AXIAL NEEDLE CAGE		AXK 1730	I05205
I05274	SCHRÄGKUGELLAGER ZWEIREIHIG	ROULEMENT À BILLES	BALL BEARING		15/ 35X15.9 3202	I05274
I05315	O-RING	JOINT TORIQUE	TORIDAL SEALING RING		54X2.5	I05315
I05320	O-RING	JOINT TORIQUE	TORIDAL SEALING RING		30X2.5	I05320
I06486	NADELKLANZ	CAGE DE PALIER À AGUILLES	NEEDLE RING		K 55X60X20	I06486
I06493	O-RING	JOINT TORIQUE	TORIDAL SEALING RING		18X2.0	I06493
I07371	SIMMERRING	BAGUE D'ÉTANCHÉITÉ	OIL-SEAL-RING		15/ 30X7	I07371
I07603	DRUCKFEDER	RESSORT DE PRESSION	PRESSURE SPRING		1.25X19X49	I07603
I07608	DRUCKFEDER	RESSORT DE PRESSION	PRESSURE SPRING		1.6X19.8X44	I07608
I07609	ZENTRIERSPITZE	CENTER SLEEVE	POINTE DE CENTRAGE		MK1 L80	I07609
I07610	ZENTRIERSPITZE	CENTER SLEEVE	POINTE DE CENTRAGE		MK1 L80	I07610
I08926	DRUCKFEDER	RESSORT DE PRESSION	PRESSURE SPRING		1.2X7.8X20	I08926
I09264	O-RING	JOINT TORIQUE	PRESSURE SPRING		35X2	I09264
I09266	BOLZEN	BOULON	BOLT			I09266
I09270	DRUCKFEDER	RESSORT DE PRESSION	PRESSURE SPRING		0.8X10X20	I09270
I10647	O-RING	JOINT TORIQUE	TORIDAL SEALING RING		36X3.0	I10647
I10724	O-RING	JOINT TORIQUE	TORIDAL SEALING RING		9X2.0	I10724
I10846	DRUCKFEDER	RESSORT DE PRESSION	PRESSURE SPRING		0.45X6.6X23	I10846
I12521	RILLENKUGELLAGER	ROULEMENT À BILLES	BALL BEARING		6205-2RS	I12521
I14188	BUNDMUTTER	ECROU A EMBASE	FLANGED NUT			I14188
I14755	O-RING	JOINT TORIQUE	TORIDAL SEALING RING		22X2.5	I14755
I15161	FLÜSSIGKEITSANZEIGE	VERRE REGARD DU NIVEAU D'HUILE	OIL-LEVEL INDICATOR		FSA76.1.1/12	I15161
I15479	TASTARM	BRAS-PALPEUR	MEASURING PINCER			I15479
I15750	MEMBRANKUPLUNG	ACCOUPLLEMENT A DIAPHRAGME	DIAPHRAGM COUPLING		200 313 04 ROD 250	I15750
I17770	KOLBENDICHTUNG	BAGUE D'ÉTANCHÉITÉ	PISTON PACKING		KDS 20-015	I17770
I17771	O-RING	JOINT TORIQUE	TORIDAL SEALING RING		16X2.0	I17771
I18131	DICHTRING	BAGUE D'ÉTANCHÉITÉ	SEALING WASHER		SD 40X52X5	I18131
I18202	MANOMETER	MANOMÈTRE	MANOMETER		NG63	I18202
I18510	V-RING	JOINT TRAPÉZOÏDAL	V-SEALING RING		VL-0300	I18510
I18512	NADEL-AXIAL-ZYLINDERROLLENLAGER	ROULEMENT À ROULEAUX	BEARING		NKXR40	I18512
I18573	O-RING	JOINT TORIQUE	TORIDAL SEALING RING		7X1.5	I18573
I19341	MONTAGESCHIENE	EMBRASE ASSOCIABLE	ASSEMBLY RAIL			I19341
I19342	BÜRSTEN	BROSSE	BRUSH		10.2509.0002	I19342
I19802	O-RING	JOINT TORIQUE	TORIDAL SEALING RING		82X2	I19802

Position Rep. Item	Bezeichnung	Désignation	Designation of part	Lieferant Fournisseur Supplier	Bestell-Nr. Référence Order no.	Ident.-Nr. No. d'ident. ID-no.
I19964	NUTSTEIN	COULISSEAU	SLIDING BLOCK			I19964
I19969	ROLLENFLACHKÄFIG	PLAQUETTES A AIGUILLES SUR GALETS	ROLLER FLAT CAGE		H 20X159 G2 SORT-1	I19969
I21738	INITIATOR	PREPARATEUR	INITIATOR		IFRM 06PI788/PL	I21738
I21862	O-RING	JOINT TORIQUE	TORIDAL SEALING RING		50X2.0	I21862
I22059	DICHTRING	BAGUE D'ÉTANCHÉITÉ	SEALING WASHER		RA 080-1/8"	I22059
I22522	NUTDICHTUNG	JOINT	SEAL			I22522
I22811	KLEMMSCHRAUBE	VIS DE SERRAGE	CLAMPING SCREW			I22811
I22992	RUNDSCHNUR	CORDE RONDE	ROUND CORD		10.2603.0504	I22992
I22993	O-RING	JOINT TORIQUE	TORIDAL SEALING RING		46X5.0	I22993
I24036	LAGER	ROULEMENT À BILLES	BALL BEARING		608-2RSR	I24036
I24431	STANGENDICHTUNG	BAGUE D'ÉTANCHÉITÉ	BAR PACKING		20X2	I24431
I26663	SIMMERING	BAGUE D'ÉTANCHÉITÉ	OIL-SEAL-RING		40/52X6	I26663
I27241	MANOMETER	MANOMÈTRE	MANOMETER		NG63	I27241
I27363	DIFFERENZDRUCKANZEIGE	AFFICHAGE DE LA PRESSION DIFFÉRENTIELLE	DIFFERENTIAL PRESSURE INDICATOR		VM 5 C.O	I27363
I29072	VAKUUMSCHALTER	INTERRUPTEUR A VIDE	VACUUM SWITCH		452 15 3 001 0.4BAR ABS	I29072
I30000	AXIAL-RADIALLAGER	PALIER AXIAL-RADIAL	AXIAL-RADIALBEARING		YRT 200	I30000
I30129	FILTERELEMENT	FILTRE IMMERGÉ	FILTER ELEMENT		0030 D 010 BN	I30129
I30418	KEGELROLLENLAGER	ROULEMENT A GALETS CONIQUES	TAPER ROLLER BEARINGS		I24070/I24112 SPEZ.	I30418
I30430	SCHWIMMERSCHALTER	INTERRUPTEUR À FLOTTEUR	FLOATING SWITCH		AFMS-L165-SB	I30430
I30475	EINFÜLL- UND BELÜFTUNGSFILTER	FILTRE DE REMPLISSAGE ET D'AÉRATION	FILLING AND VENTILATION FILTER		SES1-S	I30475
I30481	DICHTRING	BAGUE D'ÉTANCHÉITÉ	SEALING WASHER		D160NBR	I30481
I30542	ZWISCHENPLATTE SPH225	SEMELLE DE REHAUSSE	RAISING BLOCK		50MM	I30542
I31003	DIFFERENZIALSCHRAUBE	VIS DIFFÉRENTIELLE	DIFFERENTIAL SCREW			I31003
I31051	REITSTOCKPINOLE	FOURREAU DE CONTRE-POUPÉE	TAILSTOCK SLEEVE		MK4 L=317	I31051
I31059	BÜCHSE	COUSSINET	BEARING BUSH			I31059
I31061	KUGELKÄFIG	CAGE À BILLETS	BALL BEARING CAGE		50/58X45	I31061
I31064	STIRNRAD	ROUE CYLINDRIQUE	SPUR WHEEL			I31064
I31067	STEPSEAL K INNEN	STEPSEAL K INTÉRIEUR	STEPSEAL K INTERNAL		GS-55013-0500-5K 331-8307	I31067
I31643	DICHTUNG	JOINT	SEAL			I31643
I31654	DREHGEBER	RESOLVEUR	ROTARY ENCODER		ERA 180.3003	I31654
I31656	ZAHNRIEMEN	COURROIE DENTÉE	TOOTHED BELT		8MR-800-50	I31656
I31657	KLEMMSCHRAUBE	VIS DE SERRAGE	CLAMPING SCREW			I31657
I31661	DICHTPROFIL	PROFILÉ D'ÉTANCHÉITÉ	SEALING PROFILE		445 852	I31661
I31665	LAMELLENRING	JOINT	SEAL RING		FK6 ISD 125/6/2 „A-SPI“	I31665
I31666	LAMELLENRING	JOINT	SEAL RING		FK6 ISD 160/7/2 „A-SPI“	I31666
I31667	RILLENKUGELLAGER	ROULEMENT À BILLES	BALL BEARING		61916-ZZ P63	I31667

Position Rep. Item	Bezeichnung	Désignation	Designation of part	Lieferant Fournisseur Supplier	Bestell-Nr. Référence Order no.	Ident.-Nr. No. d'ident. ID-no.
I31668	RILLENKUGELLAGER	ROULEMENT À BILLES	BALL BEARING		61822-ZZ P63	I31668
I32006	KUGELGEWINDESPINDEL X-ACHSE	BROCHE FILETÉE À BILLES AXE X	BALL THREADED SPINDLE X-AXIS			I32006
I32007	KUGELGEWINDESPINDEL Z-ACHSE 1000	BROCHE FILETÉE À BILLES AXE Z 1000	BALL THREADED SPINDLE Z-AXIS 1000			I32007
I32016	AXIAL-SCHRÄGKUGELLAGERPAAR	ROULEMENT À BILLES À DISPOSITION OBLIQUE	AXIAL ANGULAR BALL BEARING		BSD 3062 C/DBB	I32016
I32024	SPINDEL	BROCHE	SPINDLE			I32024
I32029	FLANSCHBÜCHSE	DOUILLE À BRIDE	FLANGED BUSH		8X12X10	I32029
I32030	FLANSCHBÜCHSE	DOUILLE À BRIDE	FLANGED BUSH		12X18X12	I32030
I32065	O-RING	JOINT TORIQUE	TORIDAL SEALING RING		155X3	I32065
I32069	FALTENBALG 600 / 1000	SOUFFLET 600 / 1000	ACCORDIAN COVER 600 / 1000			I32069
I32076	FALTENBALG	SOUFFLET	ACCORDIAN COVER			I32076
I32077	FALTENBALG	SOUFFLET	ACCORDIAN COVER			I32077
I32105	GLEITSCHUH VORNE	COULISSEAU DE COROSSE, DEVANT	SLIDING SHOE, FRONT			I32105
I32129	GLEITSCHUH HINTEN	COULISSEAU DE COROSSE, DERRIÈRE	SLIDING SHOE, BEHIND			I32129
I32165	STEPSEAL K AUSSEN	STEPSEAL K EXTÉRIEUR	STEPSEAL K EXTERNAL		GS-55014-0630-46-K 328-8307	I32165
I32171	GUMMISCHUTZ	PROTECTION EN CAOUTCHOUC	RUBBER PROTECTION			I32171
I32196	SCHIEBELEMENT 1	ÉLÉMENT À COULISSE 1	SLIDING ELEMENT 1			I32196
I32197	SCHIEBELEMENT 2	ÉLÉMENT À COULISSE 2	SLIDING ELEMENT 1			I32197
I32198	SCHIEBELEMENT 3	ÉLÉMENT À COULISSE 3	SLIDING ELEMENT 1			I32198
I32199	SCHIEBELEMENT 4	ÉLÉMENT À COULISSE 4	SLIDING ELEMENT 1			I32199
I32203	ABDECKTUCH	CONVERTURE	COVER			I32203
I32378	O-RING	JOINT TORIQUE	TORIDAL SEALING RING		50X1.5	I32378
I32388	O-RING	JOINT TORIQUE	TORIDAL SEALING RING		48X2.0	I32388
I32428	ZAHNRINGPAAR HIRTH 2.5°	PAIR D'ANNEAU DENTÉE HIRTH 2.5°	ANNULAR GEAR PAIR HIRTH 2.5°			I32428
I32465	O-RING	JOINT TORIQUE	TORIDAL SEALING RING		80X2.5	I32465
I32466	O-RING	JOINT TORIQUE	TORIDAL SEALING RING		116X2.0	I32466
I32489	KUGELLAGER	ROULEMENT A BILLES	BALL BEARING		110/140X16	I32489
I32510	KUGELGEWINDESPINDEL Z-ACHSE 600	BROCHE FILETÉE À BILLES AXE Z 600	BALL THREADED SPINDLE Z-AXIS 600		600MM	I32510
I32511	KLEMMSCHRAUBE	VIS DE SERRAGE	CLAMPING SCREW			I32511
I32514	O-RING	JOINT TORIQUE	TORIDAL SEALING RING		90X2.5	I32514
I32539	KUGELGEWINDESPINDEL Z-ACHSE 1500	BROCHE FILETÉE À BILLES AXE Z 1500	BALL THREADED SPINDLE Z-AXIS 1500			I32539
I32622	STIRNRAD SCHRÄGVERZÄHNT	ROUE CYLINDRIQUE HELICOÏDALE	HELICAL SPUR WHEEL			I32622
I32623	SCHNECKENWELLE	VIS SANS FIN	WORM SHAFT			I32623
I32647	FALTENBALG 1500	SOUFFLET 1500	ACCORDIAN COVER 1500			I32647
I32758	FILTER	FILTRE	FILTER		HF 1F	I32758
I32964	ÖLSCHAUGLAS	INDICATEUR DE NIVEAU D'HUILE	OIL-LEVEL GAUGE		H.25 10301	I32964
I33001	SPANNSCHRAUBE	VIS DE SERRAGE	STRAINING SCREW			I33001

Position Rep. Item	Bezeichnung	Désignation	Designation of part	Lieferant Fournisseur Supplier	Bestell-Nr. Référence Order no.	Ident.-Nr. No. d'ident. ID-no.
I33010	EXZENTER	EXCENTRIQUE	ECCENTRIC			I33010
I33011	DIFFERENZIALSCHRAUBE	VIS DIFFÉRENTIELLE	DIFFERENTIAL SCREW			I33011
I33019	DICHTUNGSRING	COULISSEAU	SLIDING BLOCK			I33019
I33021	SCHLEIFSPINDEL	BROCHE PORTE-MEULE	GRINDING SPINDLE			I33021
I33112	SPANNROLLE	GALET TENDEUR	TENSION ROLLER			I33112
I33115	RUNDRIEMENSCHLEIBE	POULIE RONDE	ROUND BELT PULLEY		D75	I33115
I33122	RILLENKUGELLAGER	ROULEMENT À BILLES	BALL BEARING		6007.C3	I33122
I33123	RILLENKUGELLAGER	ROULEMENT À BILLES	BALL BEARING		6002.2RZ	I33123
I33144	STRÖMUNGSWÄCHTER	CONTROLEUR DE FLUX	FLOW MONITOR		DKM-2/1	I33144
I33148	INNENZAHNRADPUMPE	POMPE A ENGRENAGES INTERIEURS	INTERNAL GEARED WHEEL PUMP		IPZ2-HR12	I33148
I33149	WELLENKUPPLUNG	ACCOUPEMENT D'ARBRES	SHAFT COUPLING		19-24	I33149
I33275	RADIALLAGER	PALIER RADIAL	RADIALBEARING			I33275
I33276	RADIALLAGER	PALIER RADIAL	RADIALBEARING			I33276
I33277	AXIALLAGER	PALIER AXIAL	AXIALBEARING			I33277
I33278	AXIALLAGER	PALIER AXIAL	AXIALBEARING			I33278
I33289	O-RING	JOINT TORIQUE	TORIDAL SEALING RING		186X5	I33289
I33710	O-RING	JOINT TORIQUE	TORIDAL SEALING RING		115X2.0	I33710
I33711	O-RING	JOINT TORIQUE	TORIDAL SEALING RING		185X2.0	I33711
I33712	O-RING	JOINT TORIQUE	TORIDAL SEALING RING		120X2.0	I33712
I33714	O-RING	JOINT TORIQUE	TORIDAL SEALING RING		180X2.0	I33714
I33738	O-RING	JOINT TORIQUE	TORIDAL SEALING RING		145X2.5	I33738
I33739	O-RING	JOINT TORIQUE	TORIDAL SEALING RING		140X2.0	I33739
I33852	RUNDZYLINDER	CYLINDRE ROND	ROUND CYLINDER		D16-HUB198 ISO 6432	I33852
I33859	LINEARKUGELLAGER	ROULEMENT A BILLES LINEAIRE	LINEAR BALL BEARING		KH1026PP RR	I33859
I33954	RUNDZYLINDER	CYLINDRE ROND	ROUND CYLINDER		D25-HUB50 ISO 6432	I33954
I34325	POSITIONIERSTEIN	TENON	TENON		DIN 55027-5X15.9	I34325
I34448	RILLENKUGELLAGER	ROULEMENT À BILLES	BALL BEARING		6008 ZZ P4	I34448
I34672	O-RING	JOINT TORIQUE	TORIDAL SEALING RING		134X3	I34672
I34673	K-RING	ANNEAU K	K-RING		K118	I34673
I34674	K-RING	ANNEAU K	K-RING		KA140	I34674
I34888	O-RING	JOINT TORIQUE	TORIDAL SEALING RING		12.4X1.78	I34888
I34889	O-RING	JOINT TORIQUE	TORIDAL SEALING RING		3.5X1.5	I34889
I34951	SCHLEIFSPINDEL	BROCHE PORTE-MEULE	GRINDING SPINDLE			I34951
I34952	ZUFÜHRRING AXIALLAGER	NNEAU D'AMENÉE DU ROULEMENT À CHARGE AXIALE	FEED RING AXIAL BEARING			I34952
I34964	SCHLEIFSPINDEL	BROCHE PORTE-MEULE	GRINDING SPINDLE			I34964
I37224	SPRITZSCHUTZ	PROTECTION CONTRE LES PROJECTIONS	SPLASH GUARD		D125	I37224

Position Rep. Item	Bezeichnung	Désignation	Designation of part	Lieferant Fournisseur Supplier	Bestell-Nr. Référence Order no.	Ident.-Nr. No. d'ident. ID-no.
I37832	INNENZAHNRADPUMPE	POMPE A ENGRENAGES INTERIEURS	INTERNAL GEARED WHEEL PUMP		I4-4004 IPZ1-HR-10	I37832
I38063	HF-SPINDEL	BROCHE DE RECTIFICATION A HAUTE FREQUENCE	HIGH FREQUENCY SPINDLE		MFV-1230	I38063
I38064	HF-SPINDEL	BROCHE DE RECTIFICATION A HAUTE FREQUENCE	HIGH FREQUENCY SPINDLE		MFV-1260	I38064
I38336	KOLBENSTANGENDICHTUNG	GARNITURE DE LA TIGE DE PISTON	PISTON ROD GLAND		SDS 12-015	I38336
I38337	SCHMUTZABSTREIFER	RACLEUR D'IMPURETES	DIRT SCRAPER		P7	I38337
I38339	O-RING	JOINT TORIQUE	TORIDAL SEALING RING		I1X3	I38339
I38343	K-RING	ANNEAU K	K-RING		KA12	I38343
I38463	DREHGEBER	RÉSOLVEUR	ROTARY ENCODER		ROD 280C/18000 33188323	I38463
I38470	KLEMMSCHRAUBE	VIS DE SERRAGE	CLAMPING SCREW			I38470
I39443	ZAHNRIEMENSCHLEIBE	POULIE POUR COURROIE DENTÉE	TOOTHED BELT PULLEY		Z=66	I39443
I39766	TASTARM	BRAS-PALPEUR	MEASURING PINCER			I39766
I39997	SICHERHEITSSCHLEIBE	VITRES DE PROTECTION	SECURITY WINDOW			I39997
I42282	SPRITZSCHUTZ	PROTECTION CONTRE LES PROJECTIONS	SPLASH GUARD		D150X25	I42282
I42503	SICHERHEITSSVERRIEGELUNG	VERROUILLAGE DE SÛRETÉ	SECURITY SWITCH (LOCKING)		AZM_170-02ZRK-24VDC	I42503
I42549	SCHLEIFSPINDEL	BROCHE PORTE-MEULE	GRINDING SPINDLE			I42549
I42776	RUNDRIEMEN	COURROIE RONDE	ROUND BELT		5, 540MM	I42776
I42816	FLACHZYLINDER	CYLINDRE PLAT	FLAT CYLINDER		DZF-25-125-P-A	I42816
I43409	V-RING	JOINT TRAPÉZOÏDAL	V-SEALING RING		V50A	I43409
I43419	EINBAU-DREHSTROMMOTOR	MOTEUR TRIPHASÉ ENCASTRABLE	BUILT-IN THREE-PHASE A.C. MOTOR		100-MK-4	I43419
I43560	AXIAL-NADELKRANZ	CAGE À AIGUILLES AXIAL	AXIAL NEEDLE BEARING		AXK 6085	I43560
I43561	AXIAL-LAGERSCHLEIBE	RONDELLE PALIER AXIAL	AXIAL BEARING WASHER		AS 6085	I43561
I44588	ABRICHTSPINDEL	BROCHE DE DRESSAGE	DRESSING SPINDLE		I24-072185-D40	I44588
I44680	MITNEHMER	TOC D'ENTRAÎNEMENT	DRIVER			I44680
I45046	BOLZEN	AXE	BOLT			I45046
I45178	INITIATOR	PRÉPARATEUR	INITIATOR		T11 / T21	I45178
I45211	K-RING	ANNEAU K	K-RING		KA75	I45211
I45212	K-RING	ANNEAU K	K-RING		K150	I45212
I45268	DREHGEBER	RESOLVEUR	ROTARY ENCODER		ERA 180.3003	I45268
I45269	SPINDELLAGER	PALIER DE LA BROCHE	SPINDLE BEARING		B7018C.2RSD.T.P4S.K5.TUL	I45269
I45270	SPINDELLAGER	PALIER DE LA BROCHE	SPINDLE BEARING		B7016C.2RSD.T.P4S.K5.DUL	I45270
I45279	INITIATOR	PRÉPARATEUR	INITIATOR		T31	I45279
I45651	FÜHRUNGSRÖLLE	ROULEAU DE GUIDAGE	GUIDE PULLEY			I45651
I45652	MESSUHR	COMPARATEUR	DIAL GAUGE			I45652
I45809	O-RING	JOINT TORIQUE	TORIDAL SEALING RING		28X1.5	I45809
I45819	SPINDELLAGER	PALIER DE LA BROCHE	SPINDLE BEARING		HSS7006C.T.P4S.DUL	I45819
I45993	ABSTREIFER	RACLOIR	SCRAPER		PU7 50X60X7	I45993

Position Rep. Item	Bezeichnung	Désignation	Designation of part	Lieferant Fournisseur Supplier	Bestell-Nr. Référence Order no.	Ident.-Nr. No. d'ident. ID-no.
I46015	HF-SPINDEL	BROCHE DE RECTIFICATION A HAUTE FREQUENCE	HIGH FREQUENCY SPINDLE		MFZ-1090	I46015
I46418	SERVOMOTOR	SERVOMOTEUR	SERVOMOTOR		QSY 96G	I46418
I46420	WELLENKUPPLUNG	ACCOUPLLEMENT D'ARBRES	SHAFT COUPLING		19/24	I46420
I47141	KEILRIEMEN POLYFLEX	COURROIE TRAPÉZOÏDALE POLYFLEX	POLYFLEX V-BELT		3+3/5M-775JB	I47141
I47333	ROTORDICHTUNG	JOINT ROTOR	ROTOR SEAL		R4 120X124.5X3	I47333
I47345	KEILRIEMENSCHLEIBE	POULIE DE LA COURROIE TRAPEZOÏDALE	V-BELT PULLEY		D75	I47345
I47346	KEILRIEMEN POLYFLEX	COURROIE TRAPÉZOÏDALE POLYFLEX	POLYFLEX V-BELT		3/3M-580JB	I47346
I47347	KEILRIEMEN POLYFLEX	COURROIE TRAPÉZOÏDALE POLYFLEX	POLYFLEX V-BELT		3/3M-615JB	I47347
I47979	SERVOMOTOR	SERVOMOTEUR	SERVOMOTOR		QSY 155D	I47979
I47984	ZAHNRIEMENSCHLEIBE	POULIE POUR COURROIE DENTÉE	TOOTHED BELT PULLEY		Z=66	I47984
I47985	ZAHNRIEMENSCHLEIBE	POULIE POUR COURROIE DENTÉE	TOOTHED BELT PULLEY		Z=22	I47985
I47990	LAMELLENRING	JOINT	SEAL RING		FK6 ISD 100.0/4.1/1.65 INOX	I47990
I47991	LAMELLENRING	JOINT	SEAL RING		FK6 ASD 125.0/5.0/1.96 INOX	I47991
I47994	ARRETIERWELLE	ARBRE D'ARRET	LOCKING SHAFT			I47994
I48237	O-RING	JOINT TORIQUE	TORIDAL SEALING RING		60X4.0	I48237
I48444	SCHLEIFSCHEIBE	MEULE	GRINDING WHEEL		150X25X40	I48444
I48601	MASSTAB X-ACHSE	ECHELLE AXE X	SCALE X-AXIS		LF481C ML350	I48601
I48604	MASSTAB Z-ACHSE 600	ECHELLE AXE Z 600	SCALE Z-AXIS 600		LF481C ML800	I48604
I48605	MASSTAB Z-ACHSE 1000	ECHELLE AXE Z 1000	SCALE Z-AXIS 1000		LF481C ML1220	I48605
I48607	MASSTAB Z-ACHSE 1500	ECHELLE AXE Z 1500	SCALE Z-AXIS 1500		LF481C ML1720	I48607
I48634	EINBAU-DHRESTROMMOTOR	MOTEUR TRIPHASÉ ENCASTRABLE	BUILT-IN THREE-PHASE A.C. MOTOR		71-MK-2	I48634
I49017	SPANNROLLE	GALET TENDEUR	TENSION ROLLER			I49017
I49028	LITHIUM BATTERIE	BATTERIE LITHIUM	LITHIUM BATTERY		CR 203273V	I49028
I49338	FILTERPATRONE	CARTOUCHE FILTRANTE	FILTER CARTRIDGE		1829207061	I49338
I49339	FILTERPATRONE	CARTOUCHE FILTRANTE	FILTER CARTRIDGE		1829207063	I49339
I49359	FILTERELEMENT	FILTRE IMMERSÉ	FILTER ELEMENT		A93.086061	I49359
I49563	SERVOMOTOR	SERVOMOTEUR	SERVOMOTOR		QSY 116E 33987703	I49563
I49624	KEILRIEMENSCHLEIBE	POULIE DE LA COURROIE TRAPEZOÏDALE	V-BELT PULLEY		D100	I49624
I49807	WELLENKUPPLUNG	ACCOUPLLEMENT D'ARBRES	SHAFT COUPLING		24/28	I49807
I49819	SERVOMOTOR	SERVOMOTEUR	SERVOMOTOR		QSY 96G ENDAT	I49819
I49856	DICHTRING	BAGUE D'ÉTANCHÉITÉ	SEALING WASHER			I49856
I49868	ROTATIONS-LIPPENDICHTUNG	BAGUE A LEVRE ROTATIVE	ROTATIONAL LIP SEAL			I49868
I49870	WASSERVENTIL	VANNE À EAU	WATER VALVE		1"	I49870
I50125	KEILRIEMENSCHLEIBE	POULIE DE LA COURROIE TRAPEZOÏDALE	V-BELT PULLEY		D150	I50125
I50143	KABELSCHLEPP	TUBE DE CABLE	CABLE CONDUIT		0455.040.130.065-1001	I50143
I50529	MITNEHMERRING	ANNEAU D'ENTRAÎNEMENT	DRIVER RING			I50529

Position Rep. Item	Bezeichnung	Désignation	Designation of part	Lieferant Fournisseur Supplier	Bestell-Nr. Référence Order no.	Ident.-Nr. No. d'ident. ID-no.
I50537	INITIATOR	PREPARATEUR	INITIATOR		D6.5X30.5	I50537
I50679	MESSTASTER	PALPEUR	MEASURING PIN		C25	I50679
I50685	MESSTASTER	PALPEUR	MEASURING PIN		T25G	I50685
I50712	DÄMPFUNGSANSCHLAG	BUTÉE D'AMORTISSEMENT	DAMPING STOP			I50712
I50725	SCHNECKENGETRIEBE DIREKT	ENGRENAGE A VIS SANS FIN DIRECTE	DIRECT WORM GEAR			I50725
I50728	SCHNECKENGETRIEBE INDIREKT	ENGRENAGE A VIS SANS FIN INDIRECTE	INDIRECT WORM GEAR			I50728
I50803	KABELSCHLEPP	TUBE DE CABLE	CABLE CONDUIT		0455.040.130.065-1228.5	I50803
I51115	MASCHINENLAMPE	LAMPE DE LA MACHINE	MACHINE LAMP			I51115
I52113	ZUFÜHRRING RADIALLAGER	ANNEAU D'AMENÉE DU ROULEMENT À CHARGE RADIALE	FEED RING RADIAL BEARING			I52113
I52293	ANSCHLUSSFLANSCH GERADE	BOURRELET DE RACCORDEMENT	CONNECTING FLANGE STRAIGHT		BGG-70	I52293
I52292	WELLROHR	CULOT TUBULAIRE	TUBE BEND		CYLG-70B 1300	I52292
I52716	INITIATOR	PREPARATEUR	INITIATOR		516-371-SA 15-C-S 49	I52716
I53025	KABELSCHLEPP	TUBE DE CABLE	CABLE CONDUIT		0665.040.075.100-997	I53025
I53026	KABELSCHLEPP	TUBE DE CABLE	CABLE CONDUIT		0665.040.075.100-1197	I53026
I53027	KABELSCHLEPP	TUBE DE CABLE	CABLE CONDUIT		0665.040.075.100-1596	I53027
I53311	DREHSTROMMOTOR	MOTEUR TRIPHASÉ	THREE-PHASE AC MOTOR		0.37KW	I53311
I53402	DRUCKSCHALTER	INTERRUPTEUR MANOMETRIQUE	PRESSURE SWITCH		0166 409 03 1 051	I53402
I53471	WELLROHR	CULOT TUBULAIRE	TUBE BEND		CYLG-70B 2200	I53471
I53871	KABELSCHLEPP	TUBE DE CABLE	CABLE CONDUIT		0182.20.037-810	I53879
I53891	SCHUTZTÜRANTRIEB MIT ZAHNRAD	ENTRAINEMENT A ROUE DENTEE DE LA PORTE DE PROTECTION	PROTECTIVE DOOR DRIVE WITH GEARED WHEEL		NT-4 9-09-159	I53891
I53892	UMLENKEINHEIT AUTOM. TÜRANTRIEB	UNITE DE RENVOI DE L'ENTRAINEMENT AUTOMATIQUE DE LA PORTE	DEFLECTION UNIT AUTOM. DOOR DRIVE		4-214-145	I53892
I53894	ZAHNRIEMEN TÜRANTRIEB	COURROIE DENTEE DE L'ENTRAINEMENT DE LA PORTE	TOOTHED BELT DOOR DRIVE		AT-10	I53894
I54193	MESSTASTER	PALPEUR	MEASURING PIN		A90	I54193
I54288	DICHTUNG	JOINT	SEAL		D30GK	I54288
I54623	DREHGEBER	RESOLVEUR	ROTARY ENCODER		W770	I54623
I54634	INITIATOR	PREPARATEUR	INITIATOR		516-324-G-E4-C-S 49-00.5	I54634
I56200	LITHIUM BATTERIE	BATTERIE LITHIUM	LITHIUM BATTERY		CR 2450N	I56200
I56557	ZAHNRINGPAAR HIRTH 1.0°	PAIR D'ANNEAU DENTÉE HIRTH 1.0°	ANNULAR GEAR PAIR HIRTH 1.0°			I56557

Längsschlitten Z-Achse / Chariot longitudinal axe Z / Longitudinal slide Z-axis

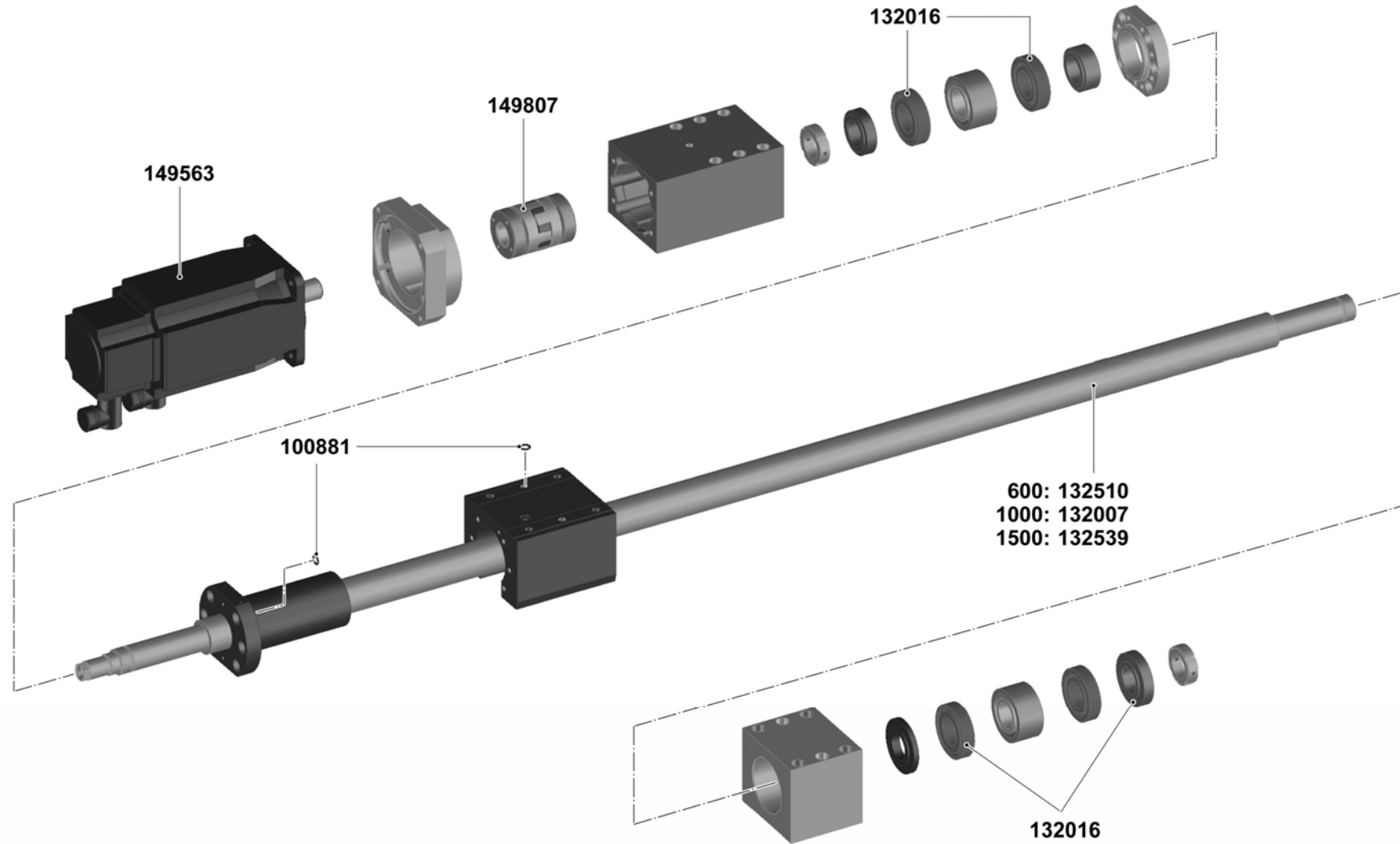

Längsschlitten Untertisch / Chariot longitudinal table inférieure / Longitudinal slide lower table

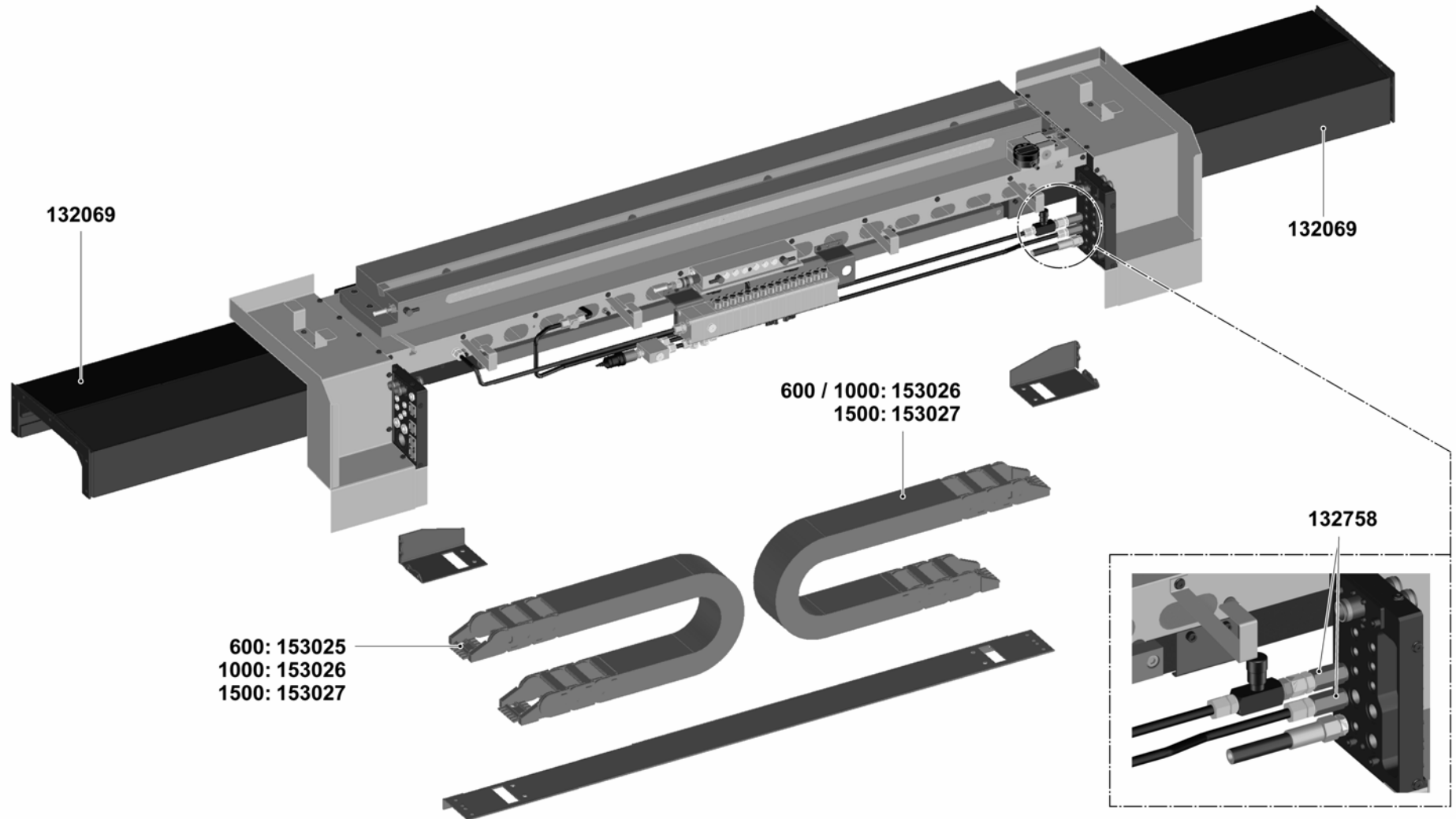

293336-2/6

Längsschlitten Untertisch / Chariot longitudinal table inférieure / Longitudinal slide lower table

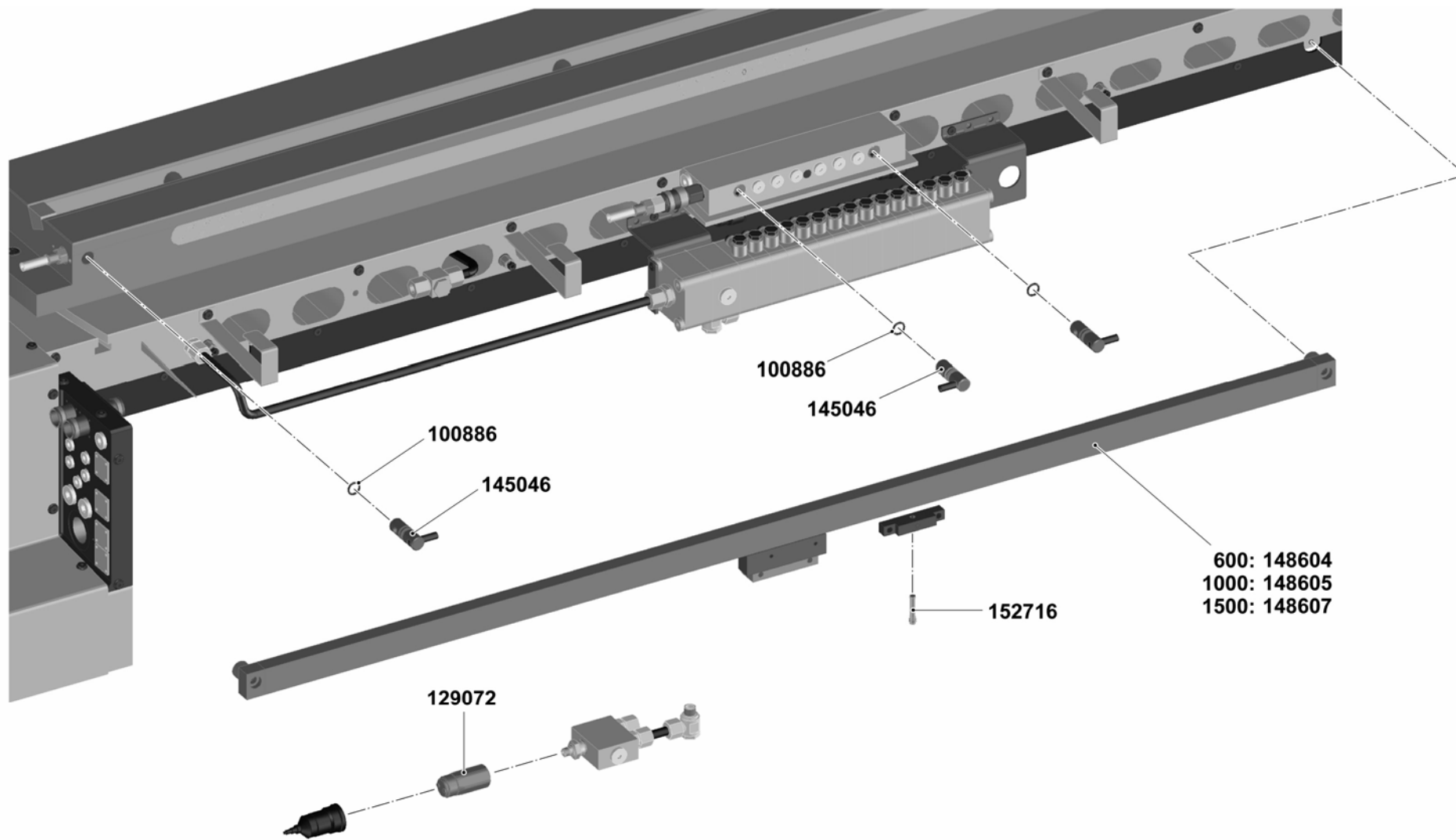

Längsschlitten Obertisch / Chariot longitudinal table supérieure / Longitudinal slide upper table

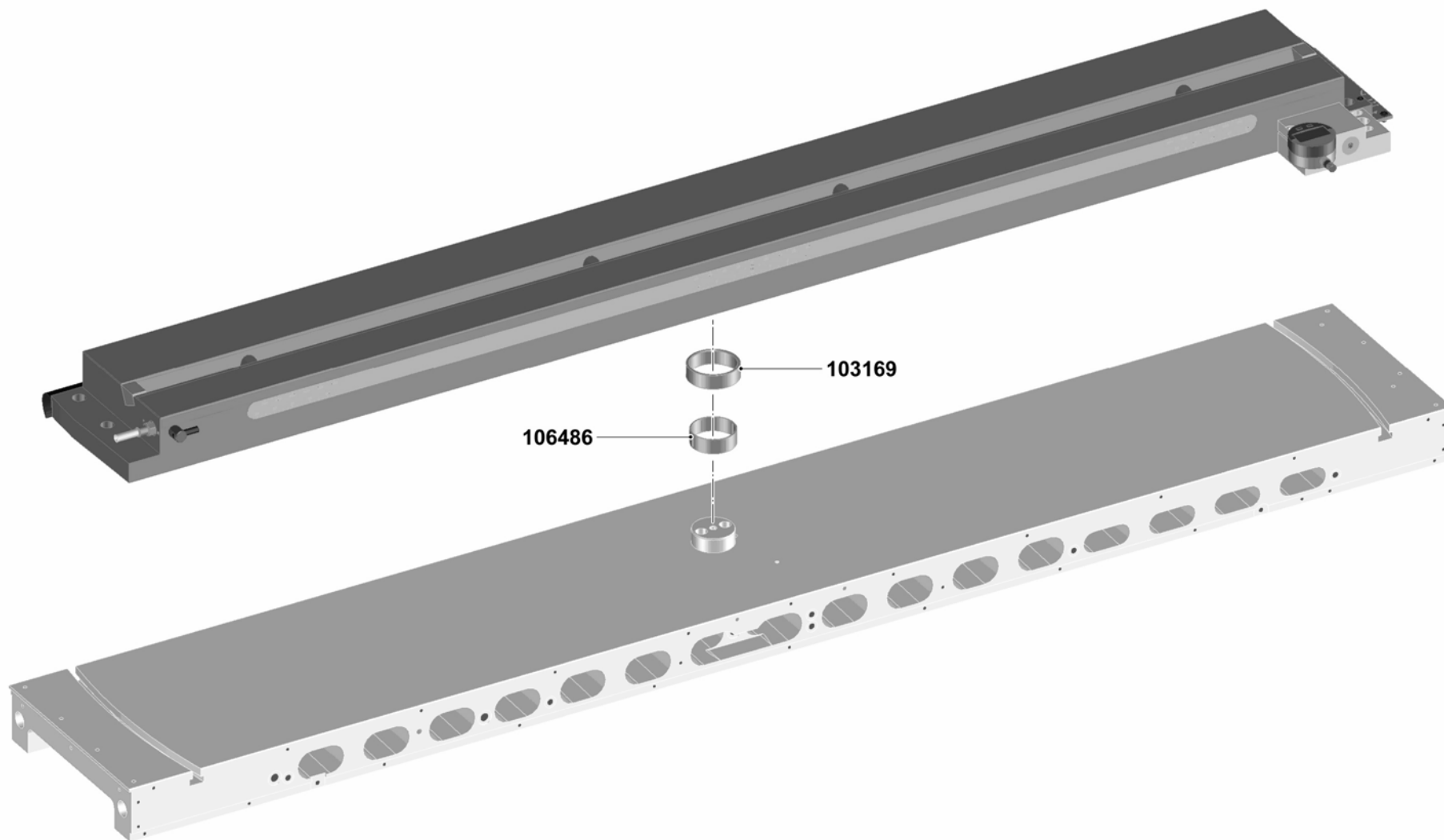

293336-4/6

Längsschlitten Obertisch / Chariot longitudinal table supérieure / Longitudinal slide upper table

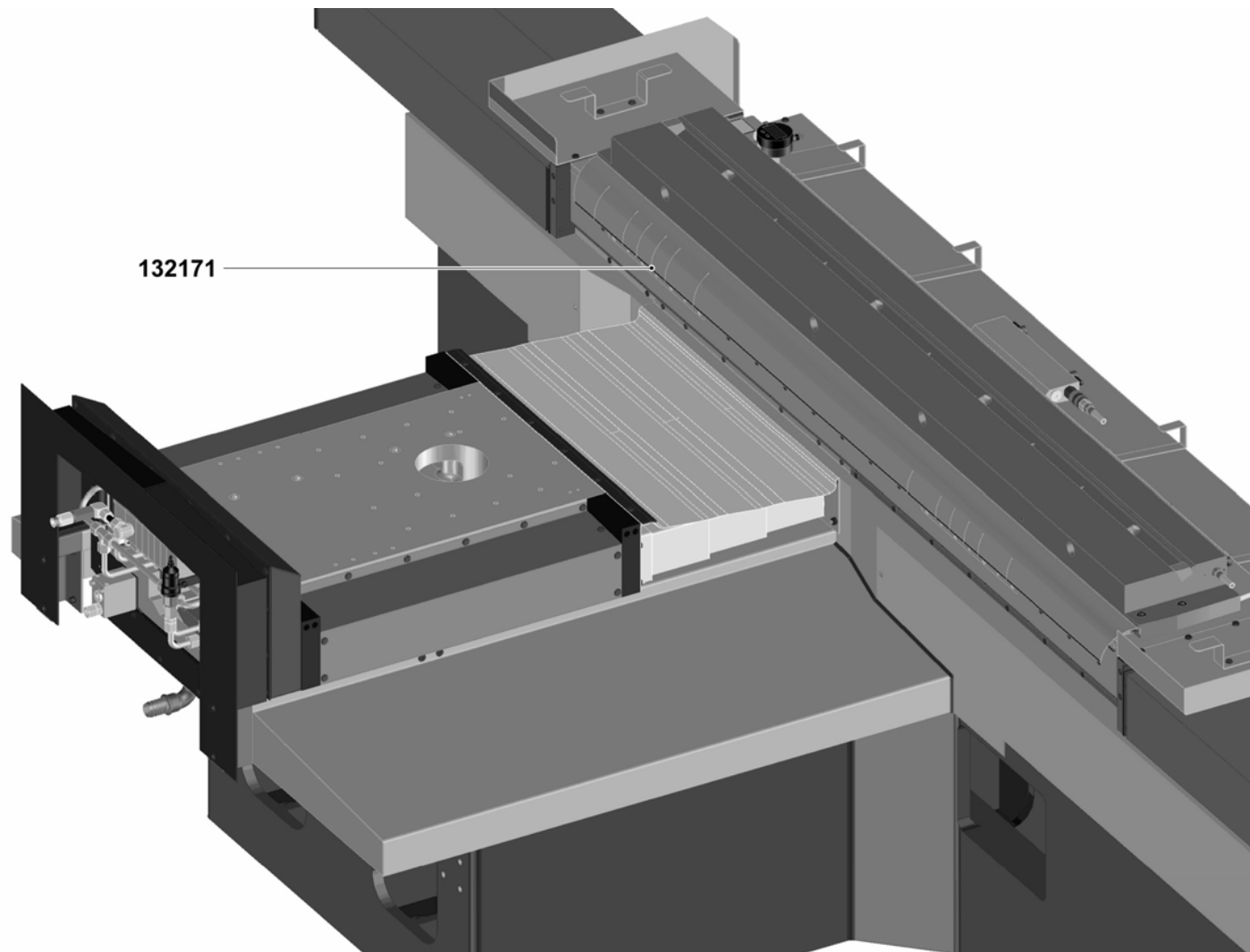

293336-5/6

Längsschlitten Obertisch / Chariot longitudinal table supérieure / Longitudinal slide upper table

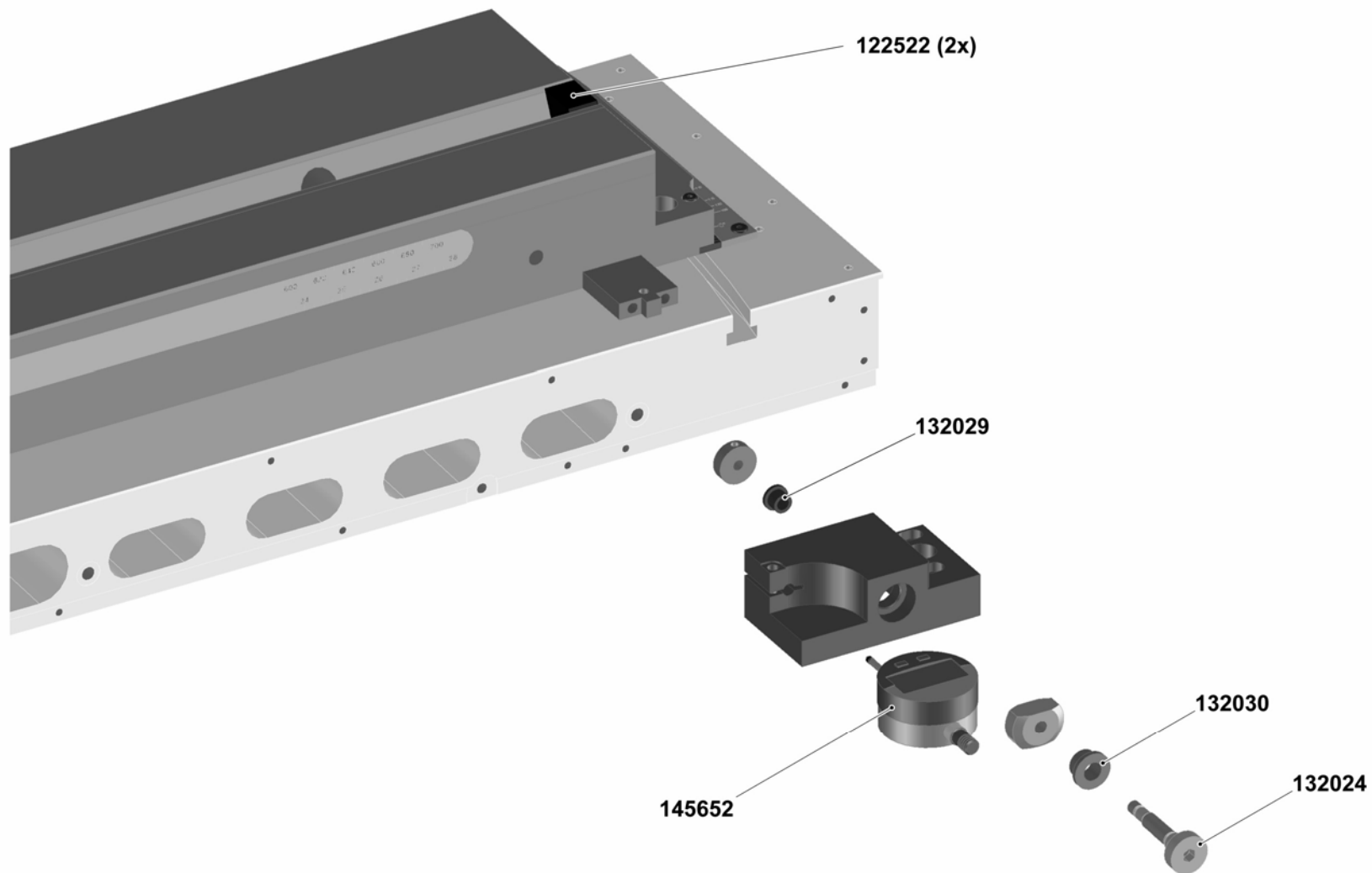

Schleifschlitten X-Achse / Chariot porte-meule axe X / Grinding slide X-axis

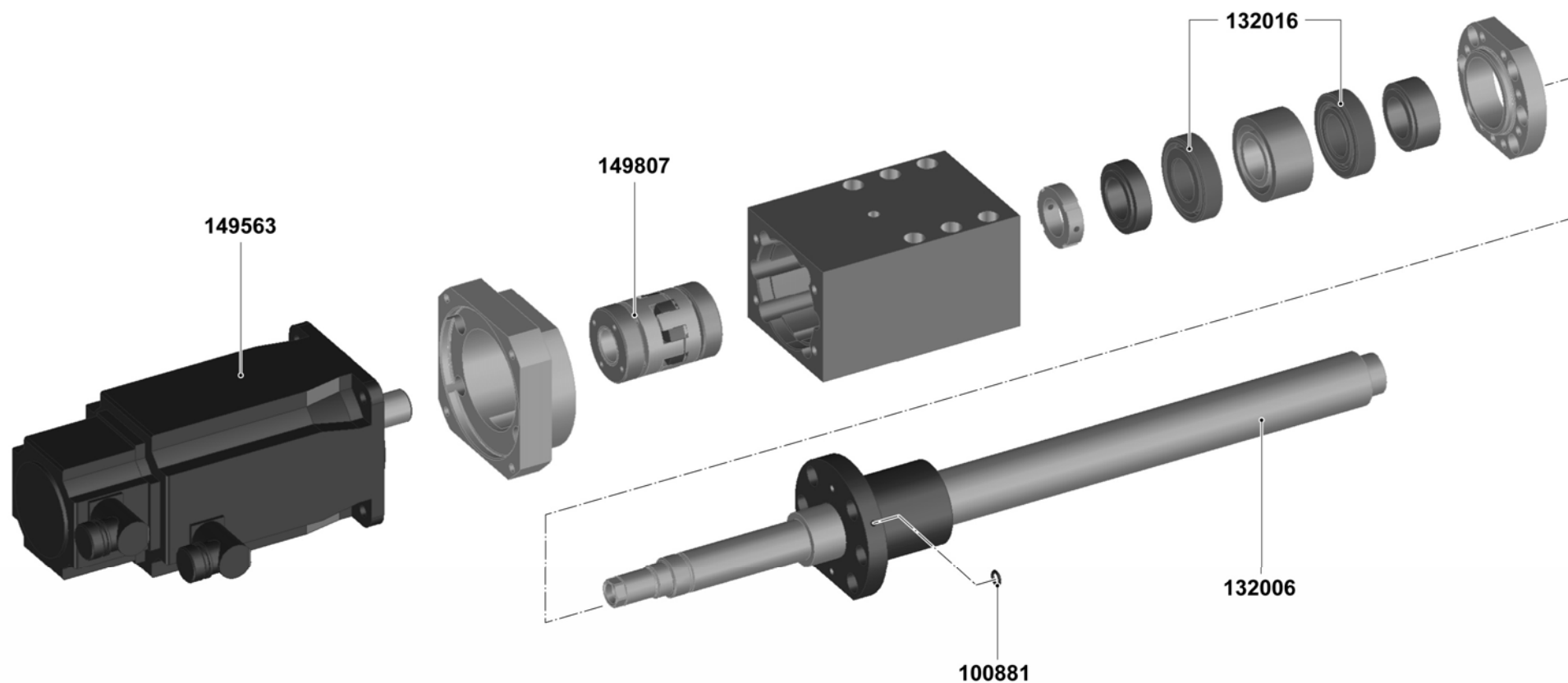

293335-1/4

Schleifschlitten X-Achse / Chariot porte-meule axe X / Grinding slide X-axis

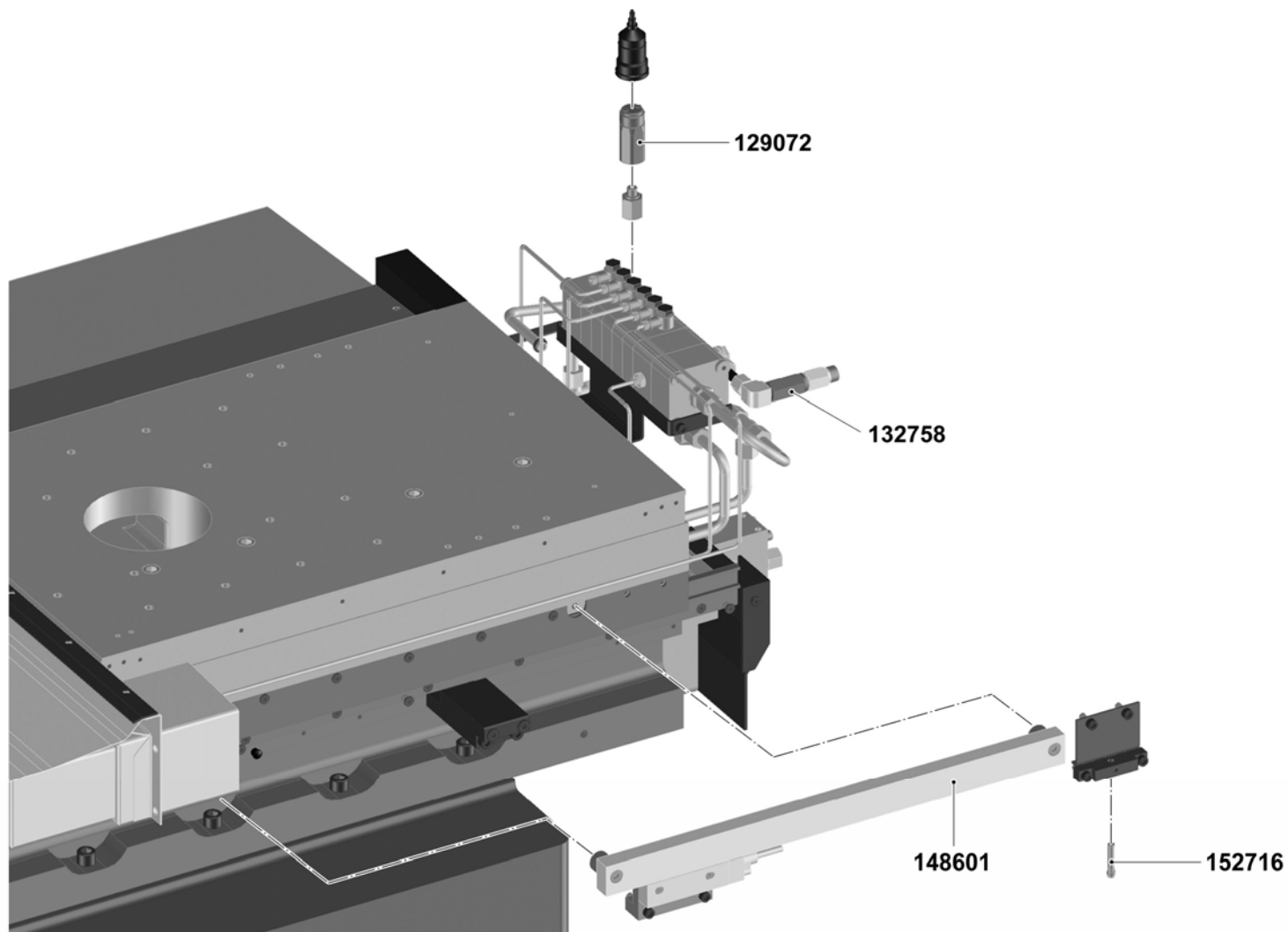

293335-2/4

Schleifschlitten X-Achse / Chariot porte-meule axe X / Grinding slide X-axis

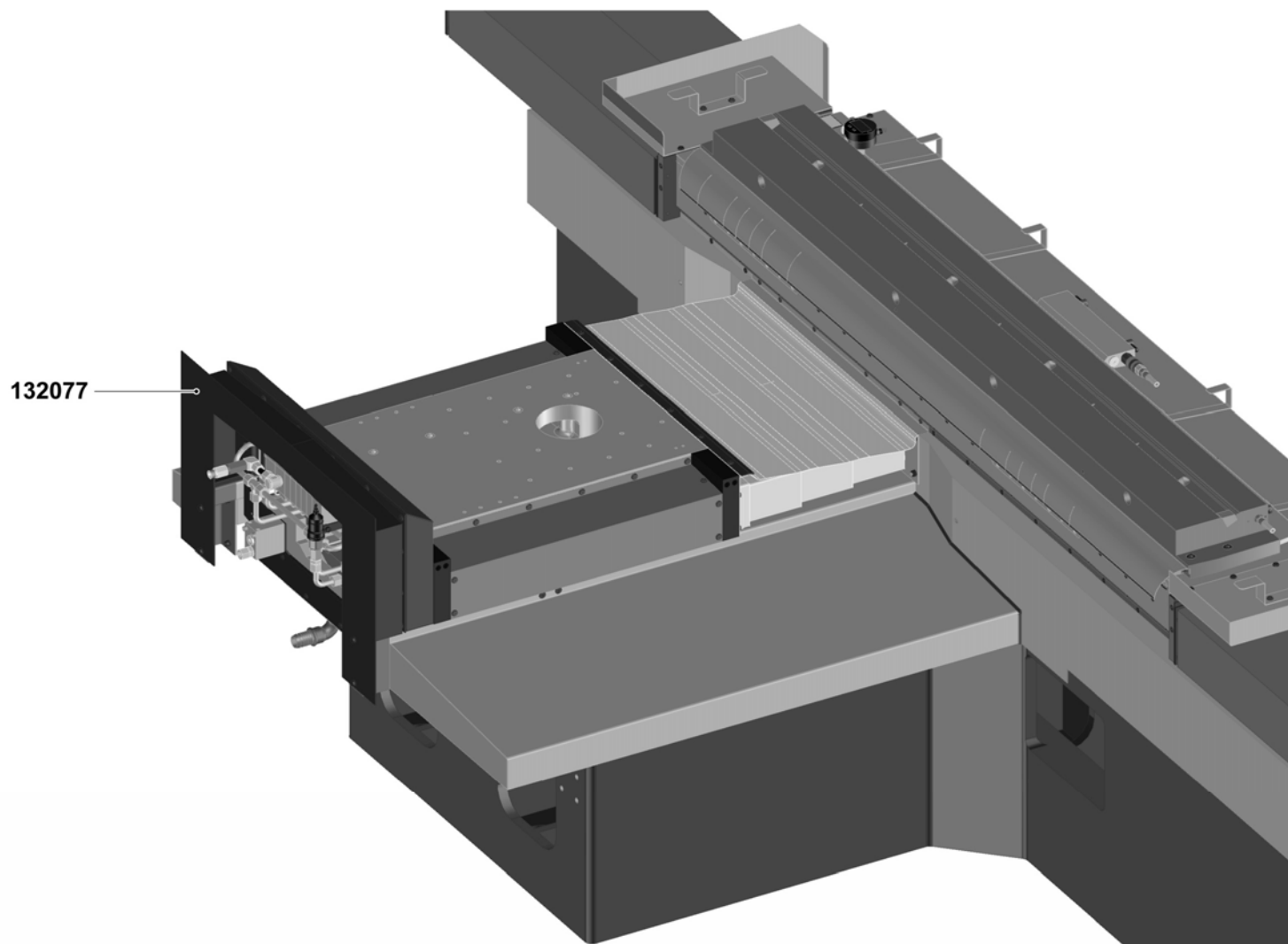

293335-3/4

Schleifschlitten X-Achse / Chariot porte-meule axe X / Grinding slide X-axis

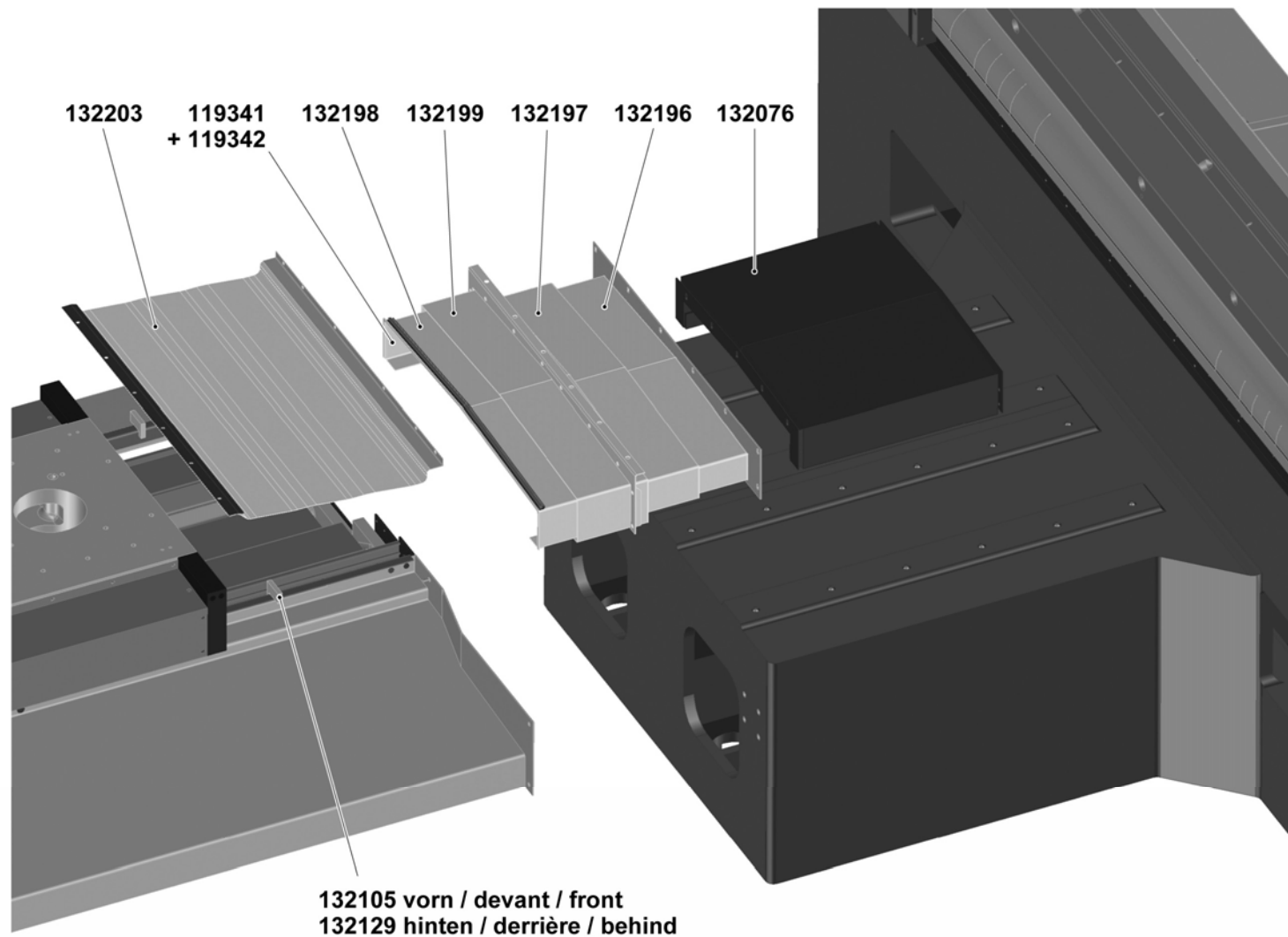

Indexierachse / Axe d'indexation / Indexing axis

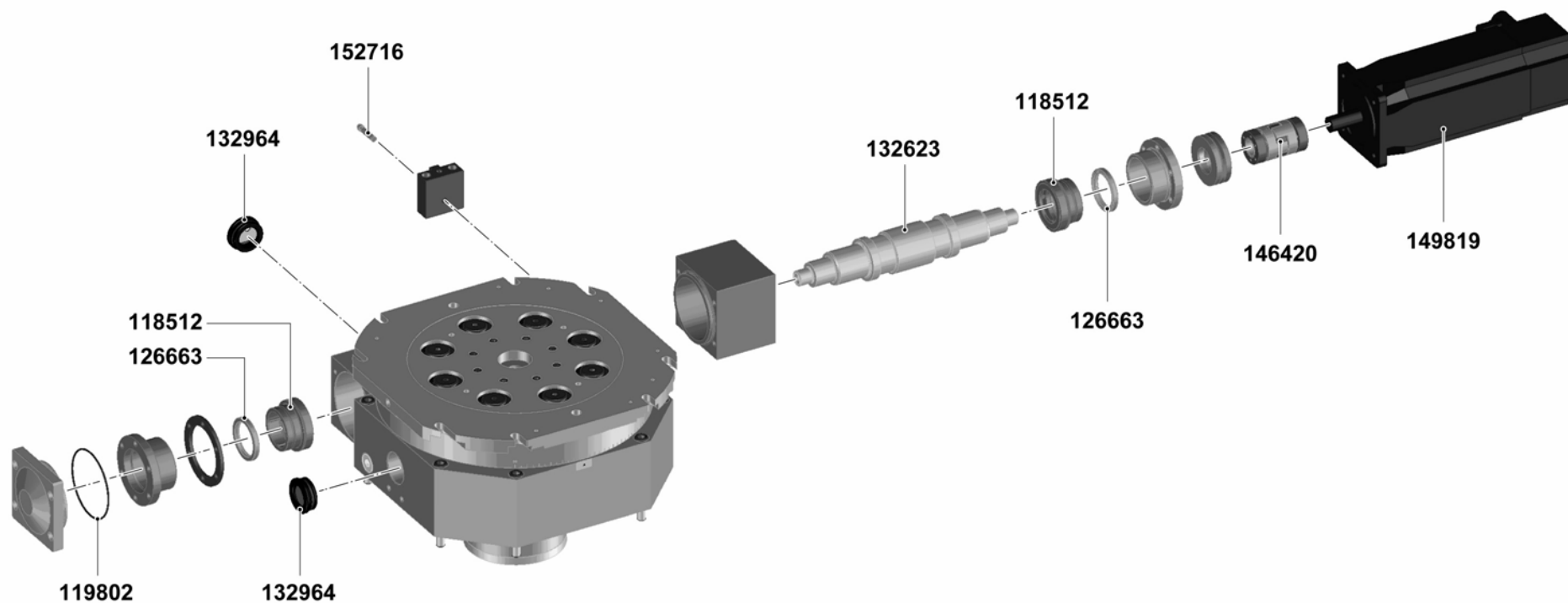

293338-1/2

Indexierachse / Axe d'indexation / Index axis

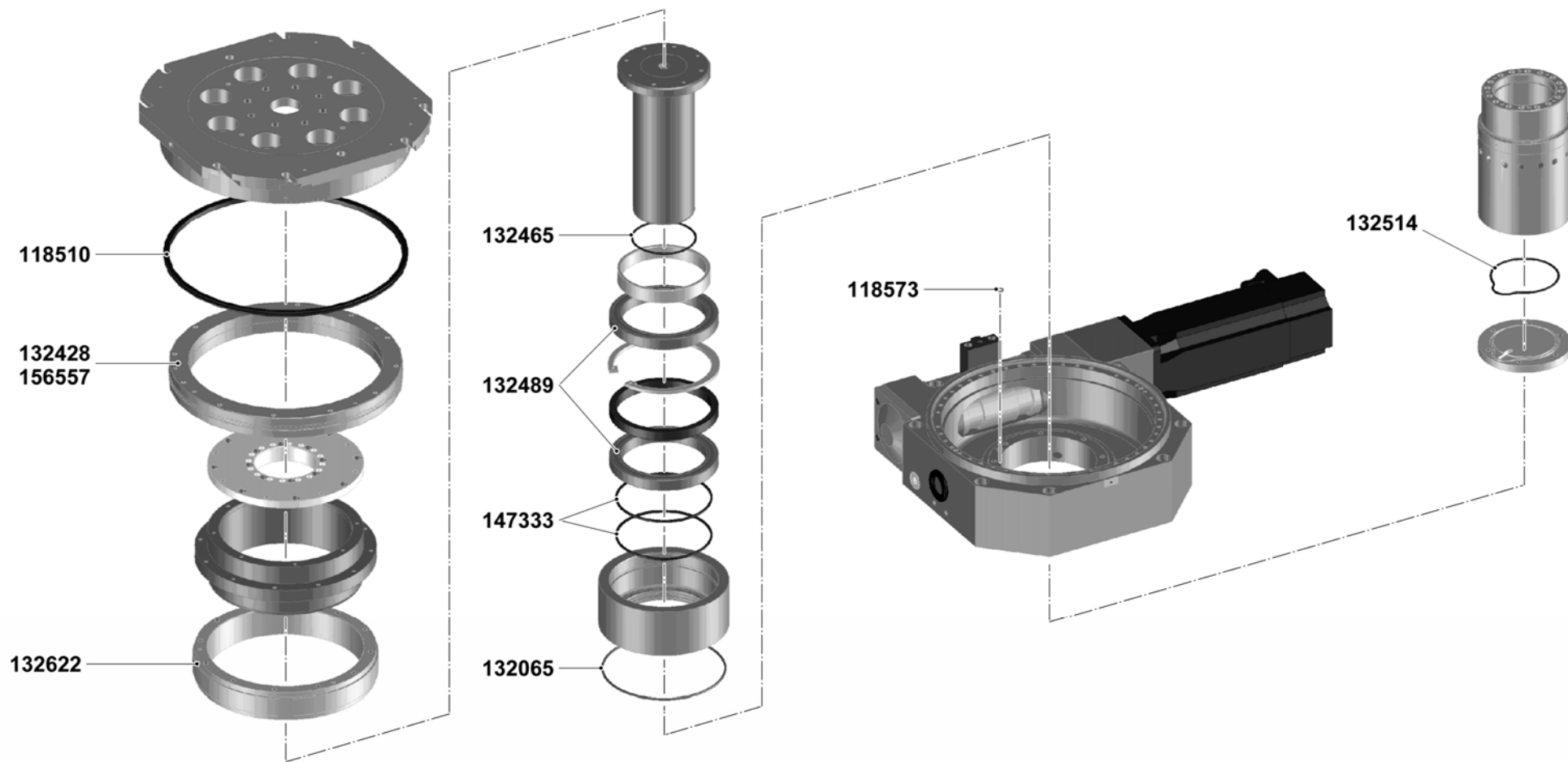

293338-2/2

B-Achse direkt-indirekt / Axe B directe-indirecte / B-axis direct-indirect

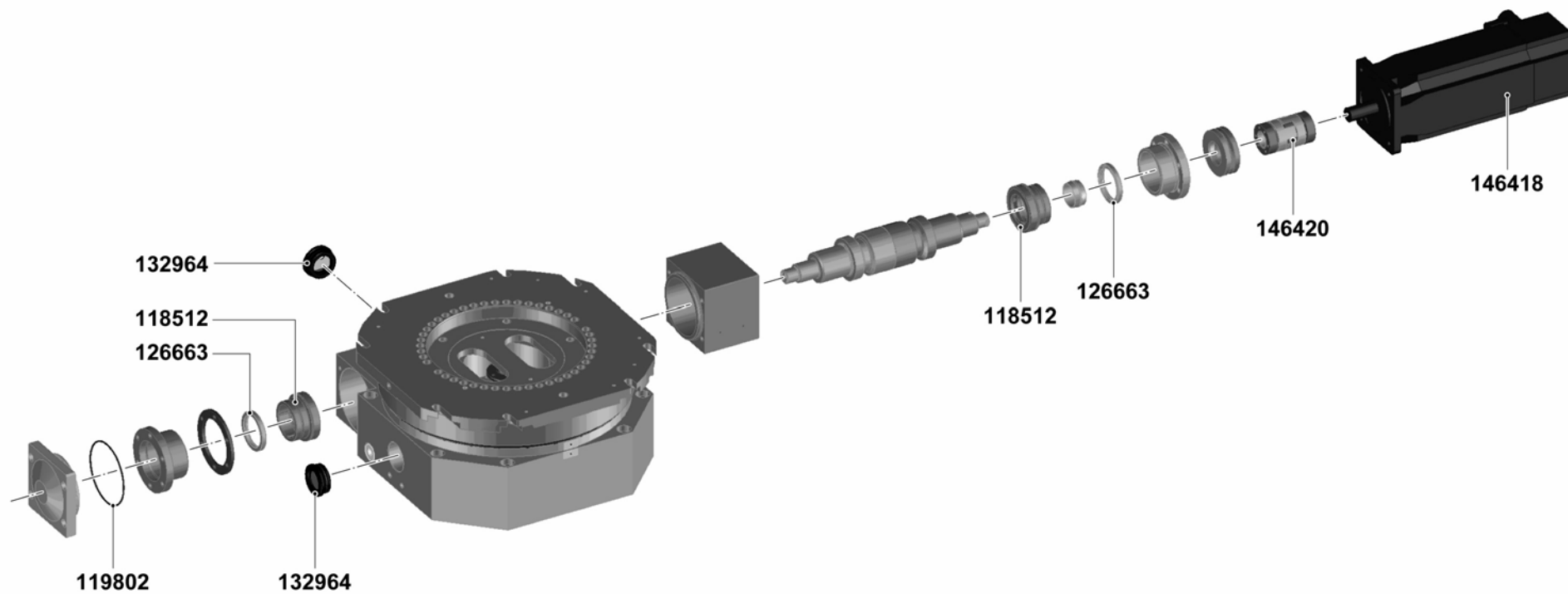

293337-1/3

B-Achse direkt / Axe B directe / B-axis direct

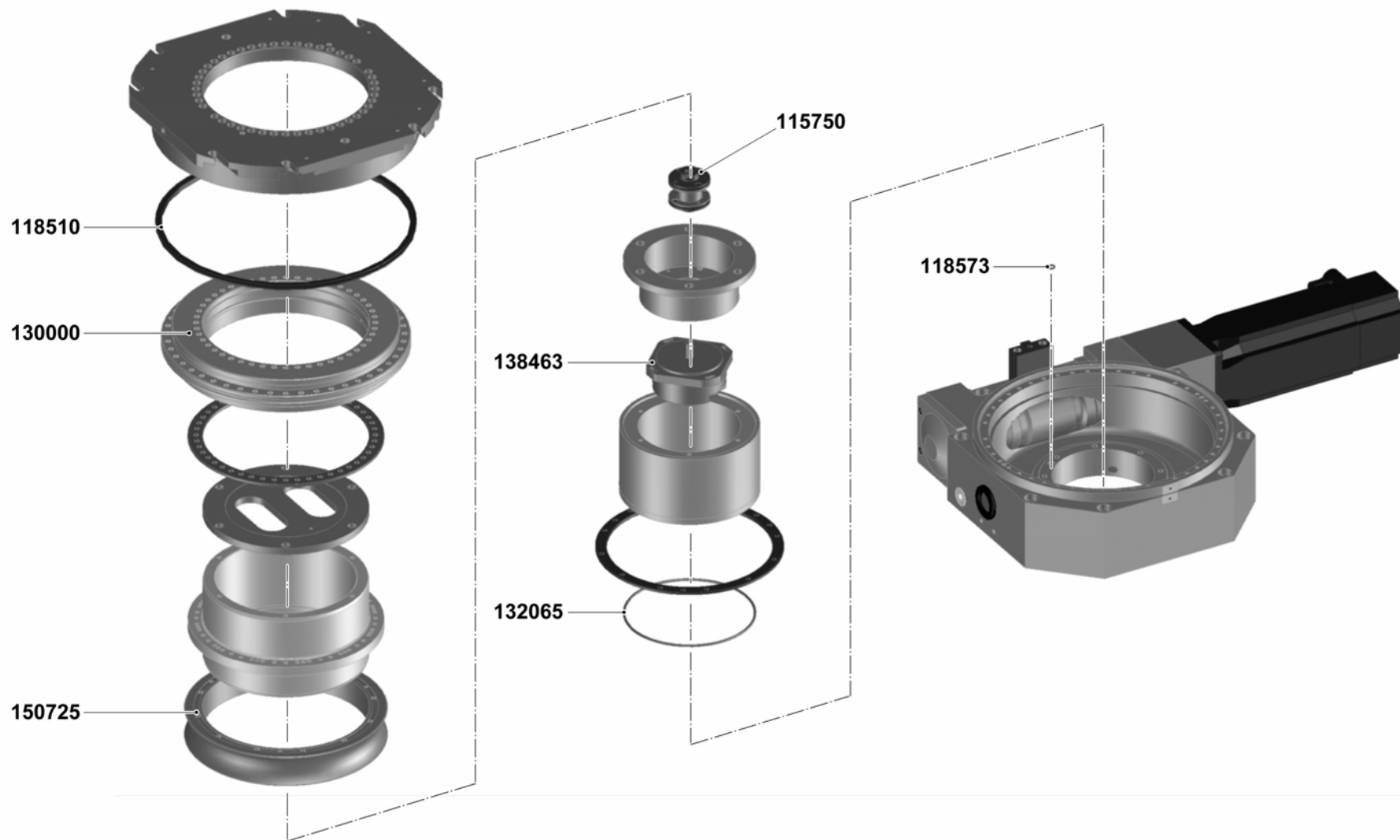

B-Achse indirekt / Axe B indirecte / B-axis indirect

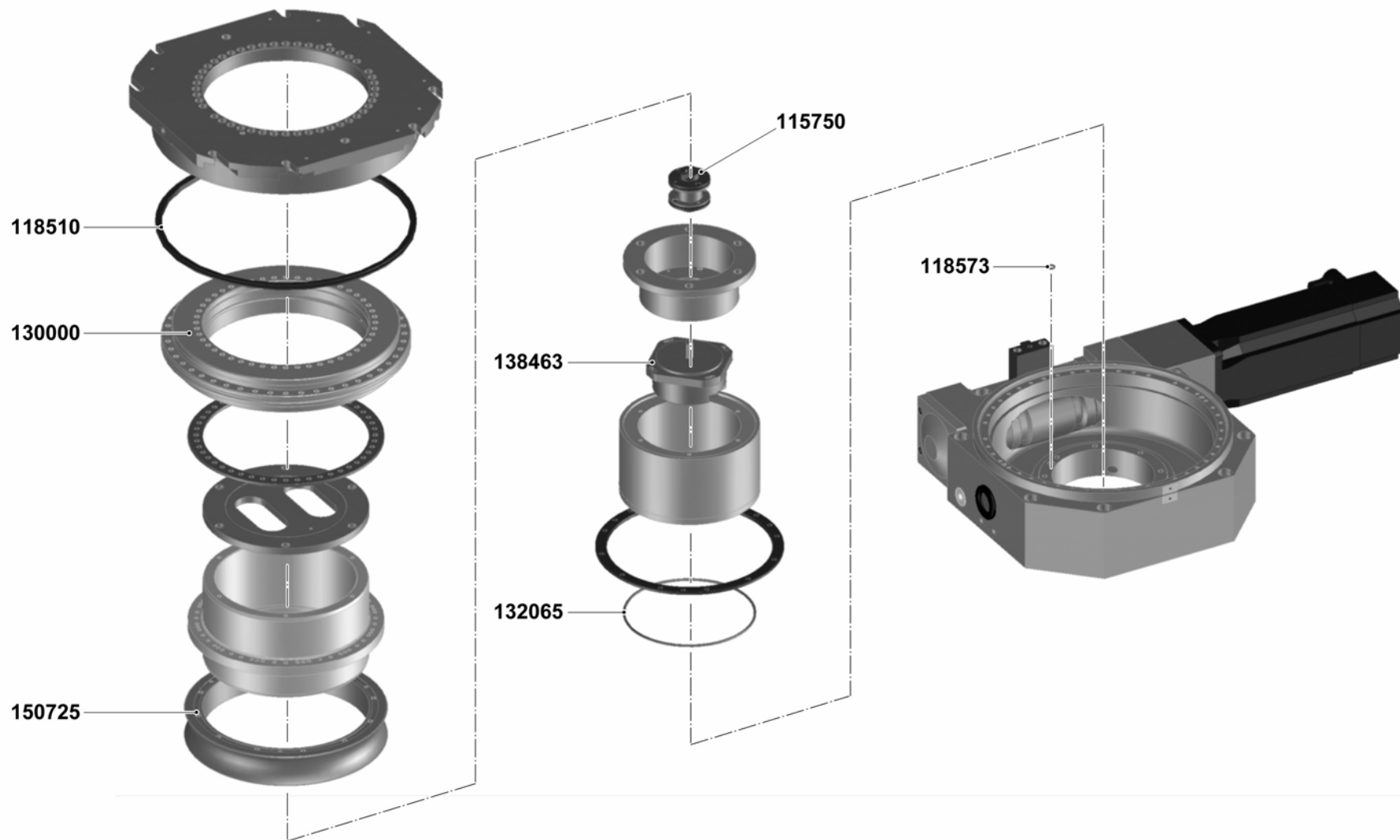

Schleifkopf Aussenschleifen / Poupée porte-meule rectification extérieure / Wheelhead O.D. grinding

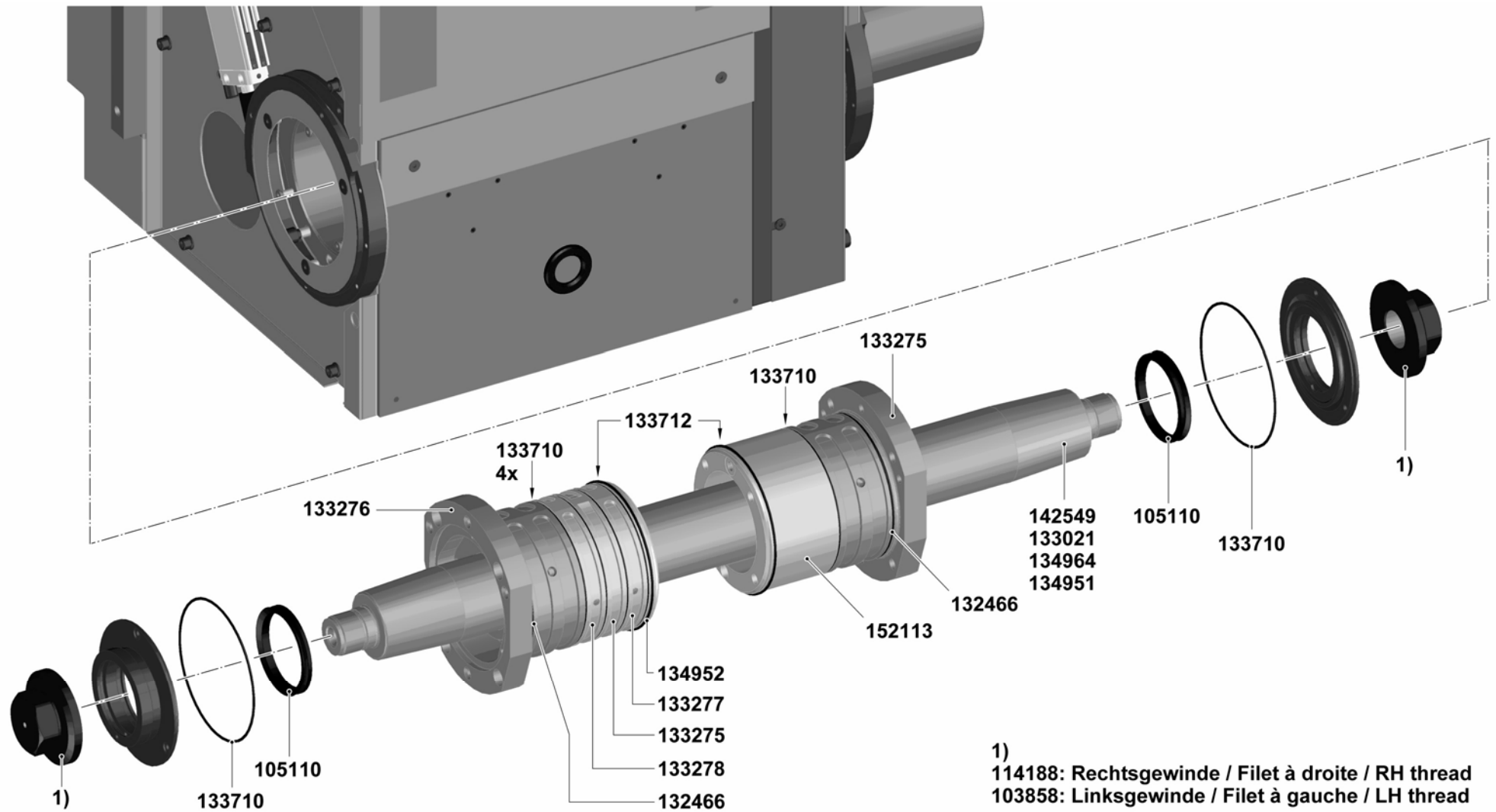

293341-1/5

Schleifkopf Aussenschleifen / Poupée porte-meule rectification extérieure / Wheelhead O.D. grinding

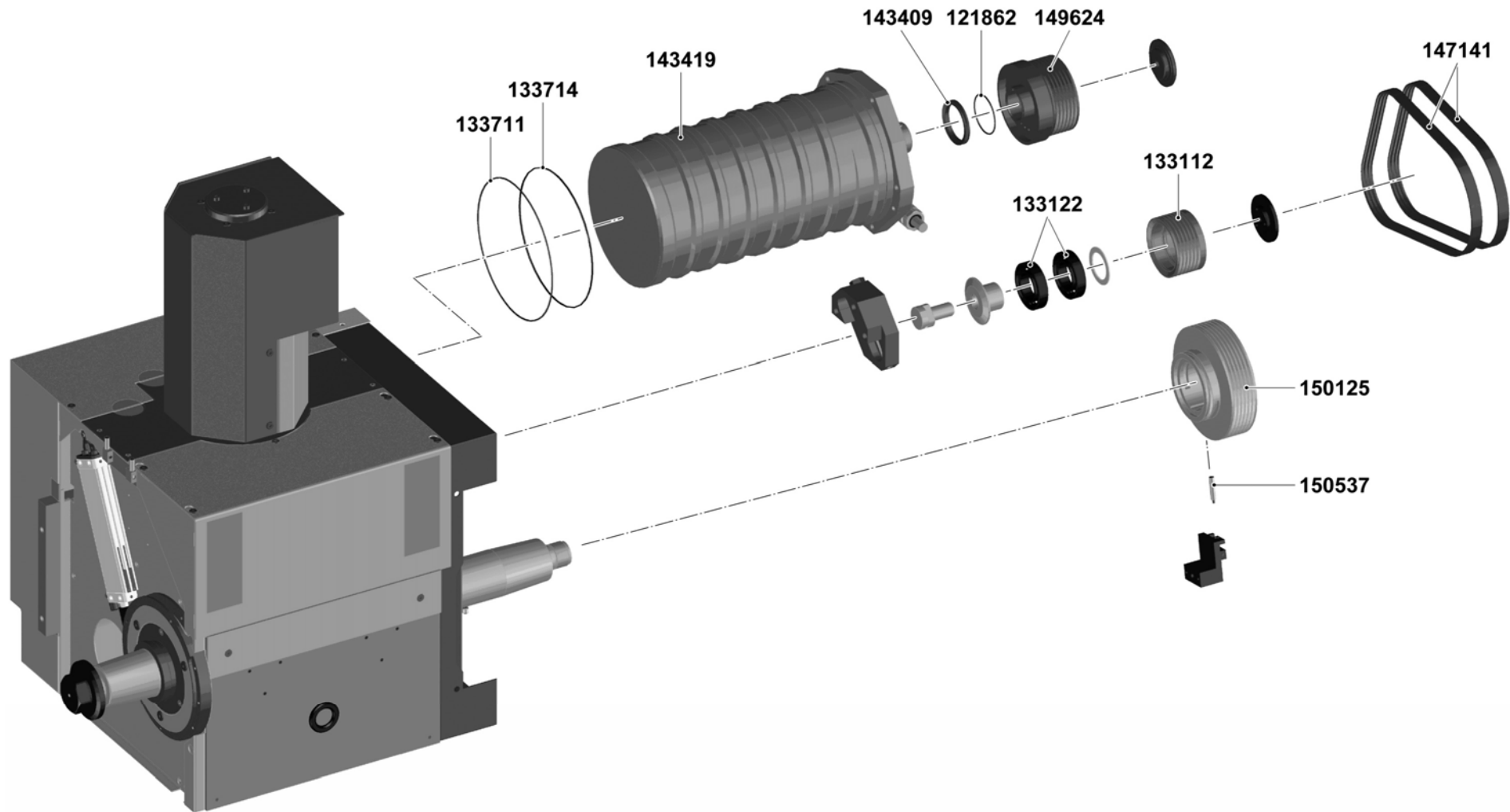

Schleifkopf Aussenschleifen / Poupée porte-meule rectification extérieure / Wheelhead O.D. grinding

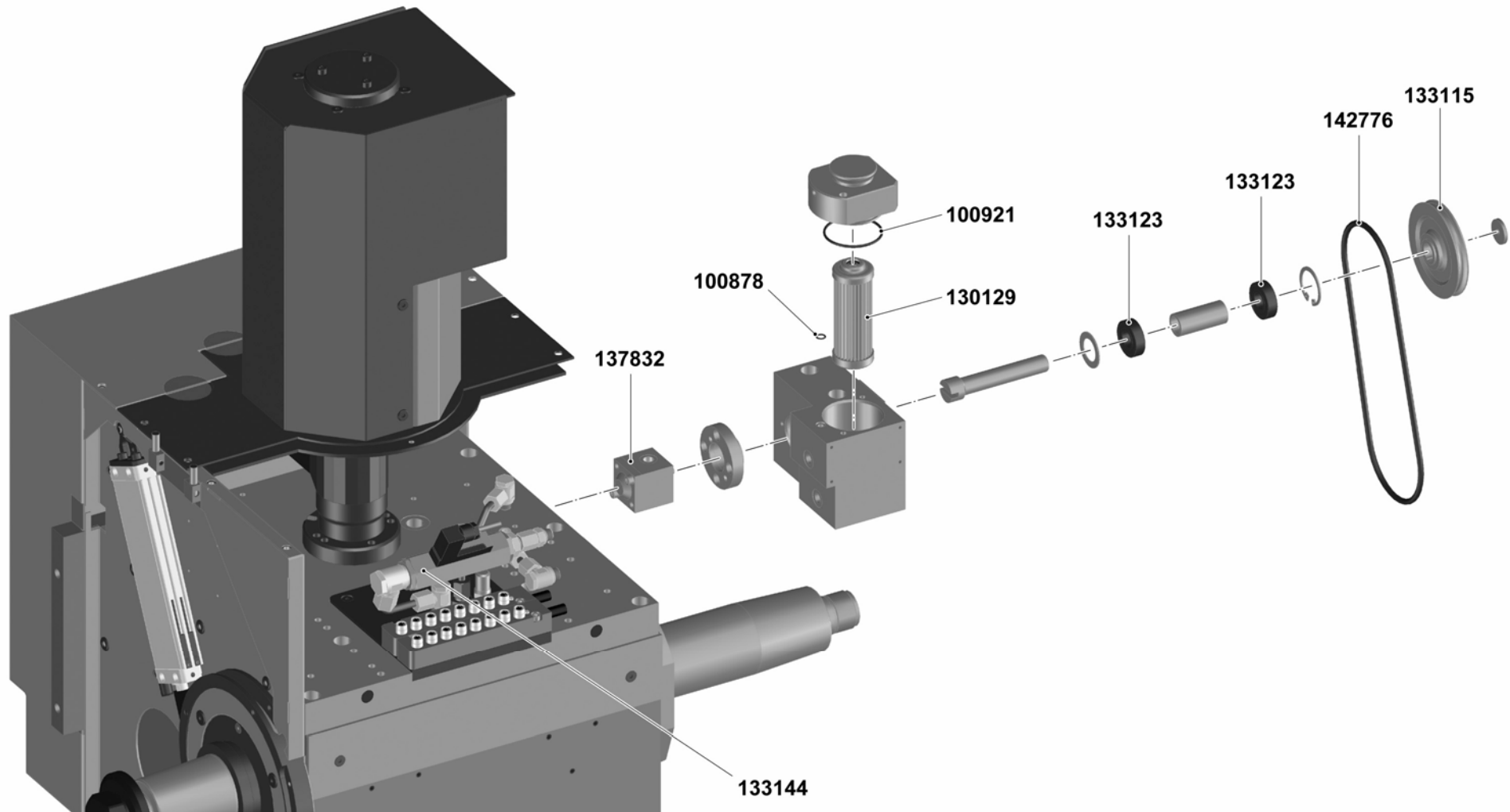

Schleifkopf Aussenschleifen / Poupée porte-meule rectification extérieure / Wheelhead O.D. grinding

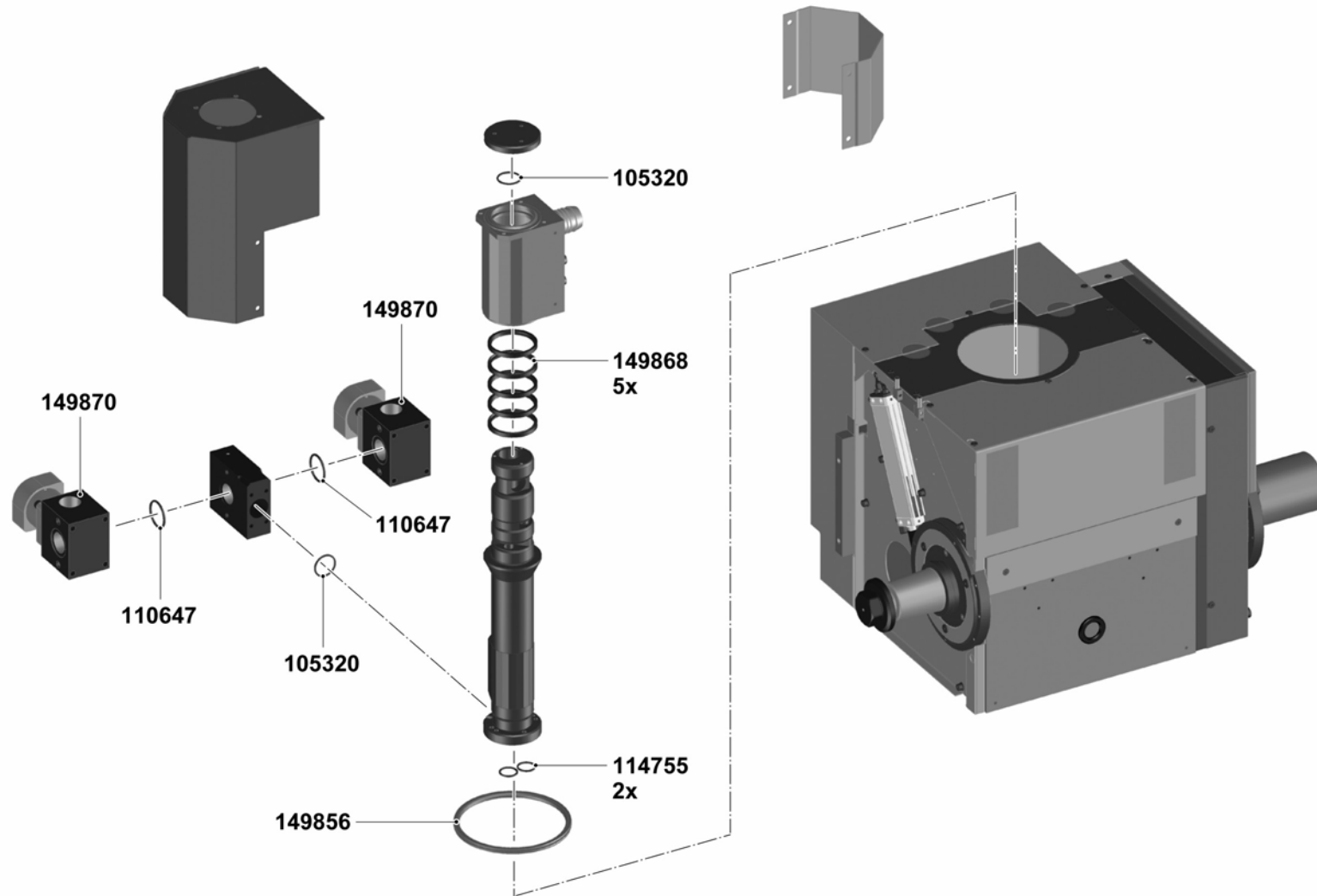

Schleifkopf Aussenschleifen / Poupée porte-meule rectification extérieure / Wheelhead O.D. grinding

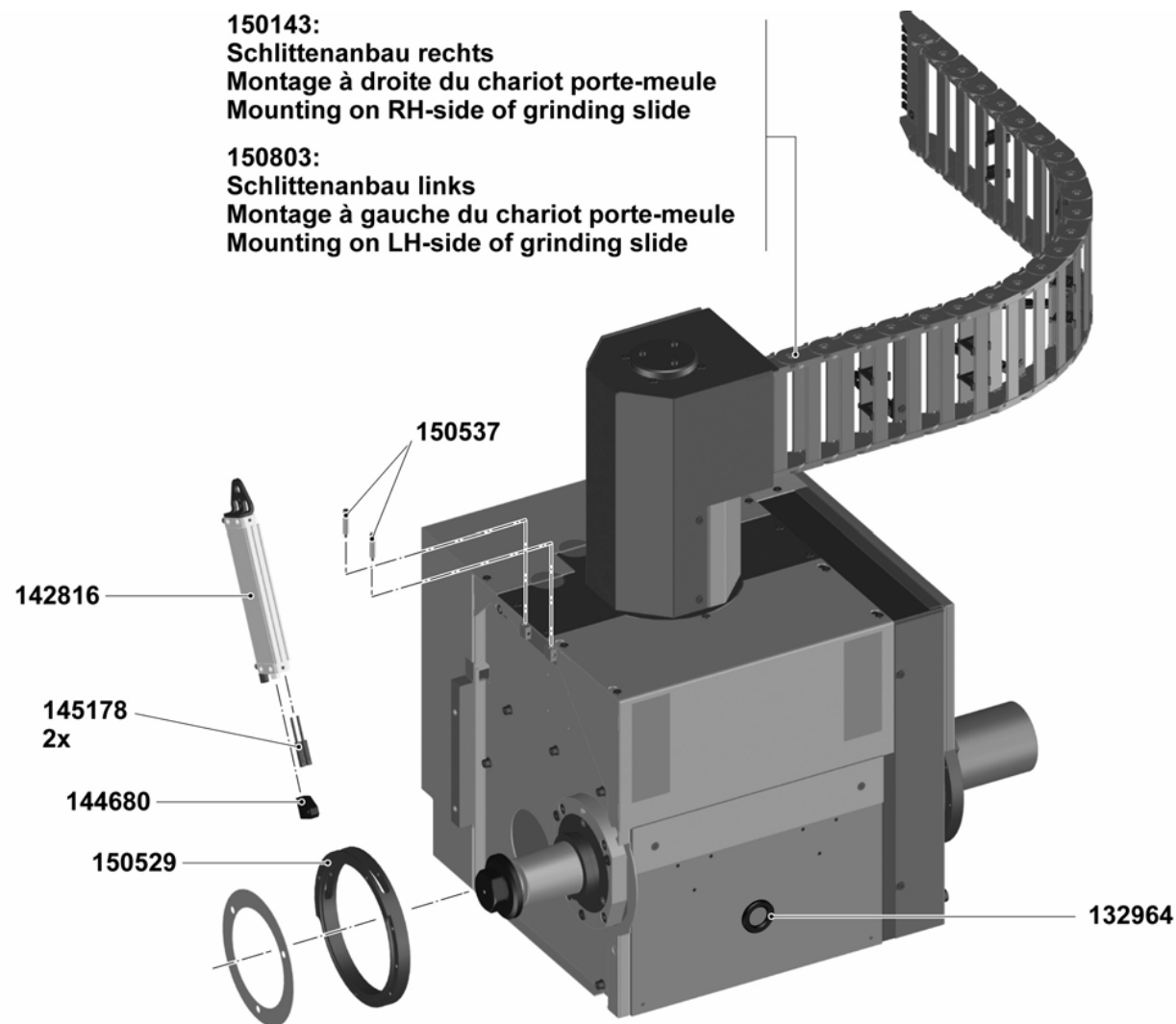

Schleifkopf Innenschleifen / Poupée porte-meule rectification intérieure / Wheelhead I.D. grinding

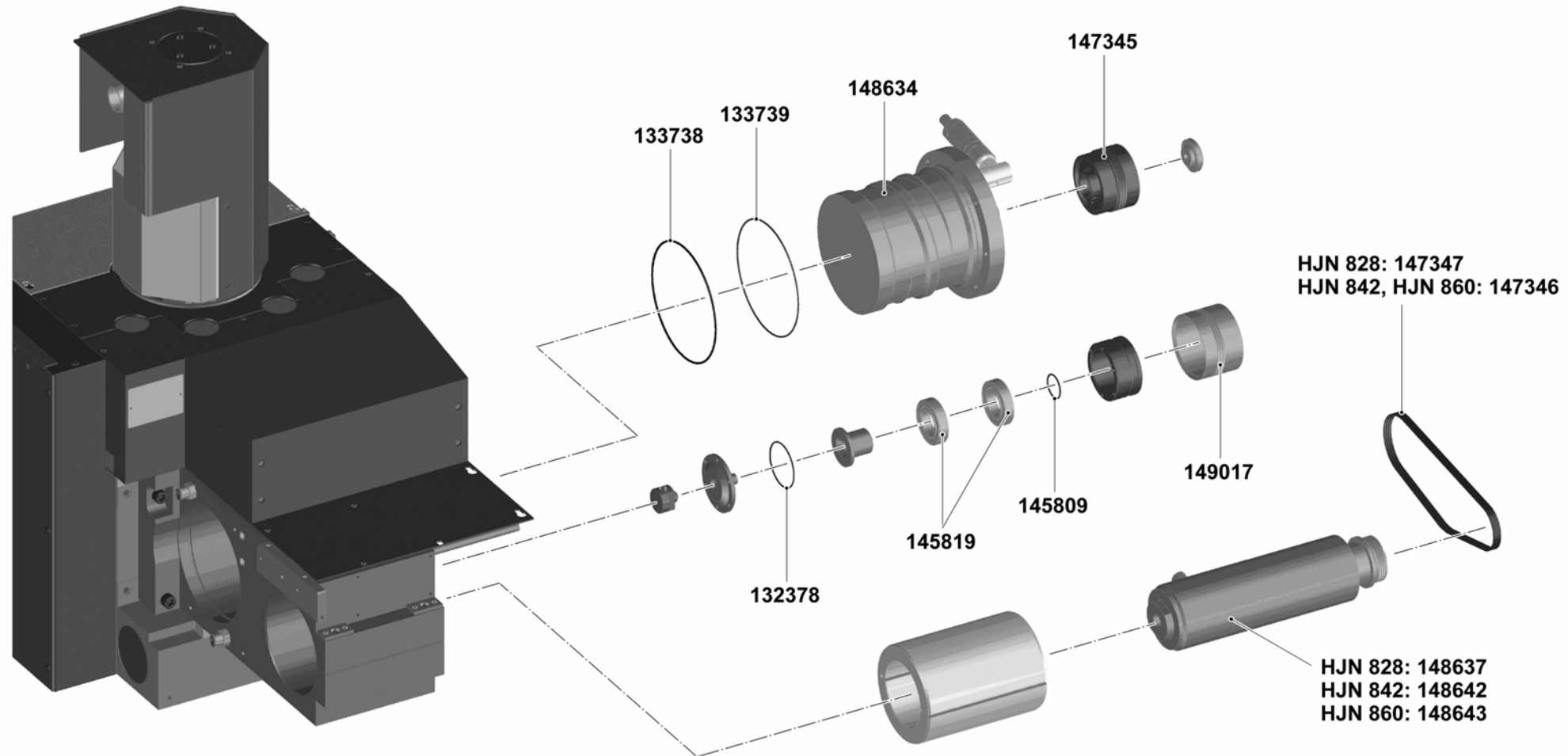

293342-1/3

Schleifkopf Innenschleifen / Poupée porte-meule rectification intérieure / Wheelhead I.D. grinding

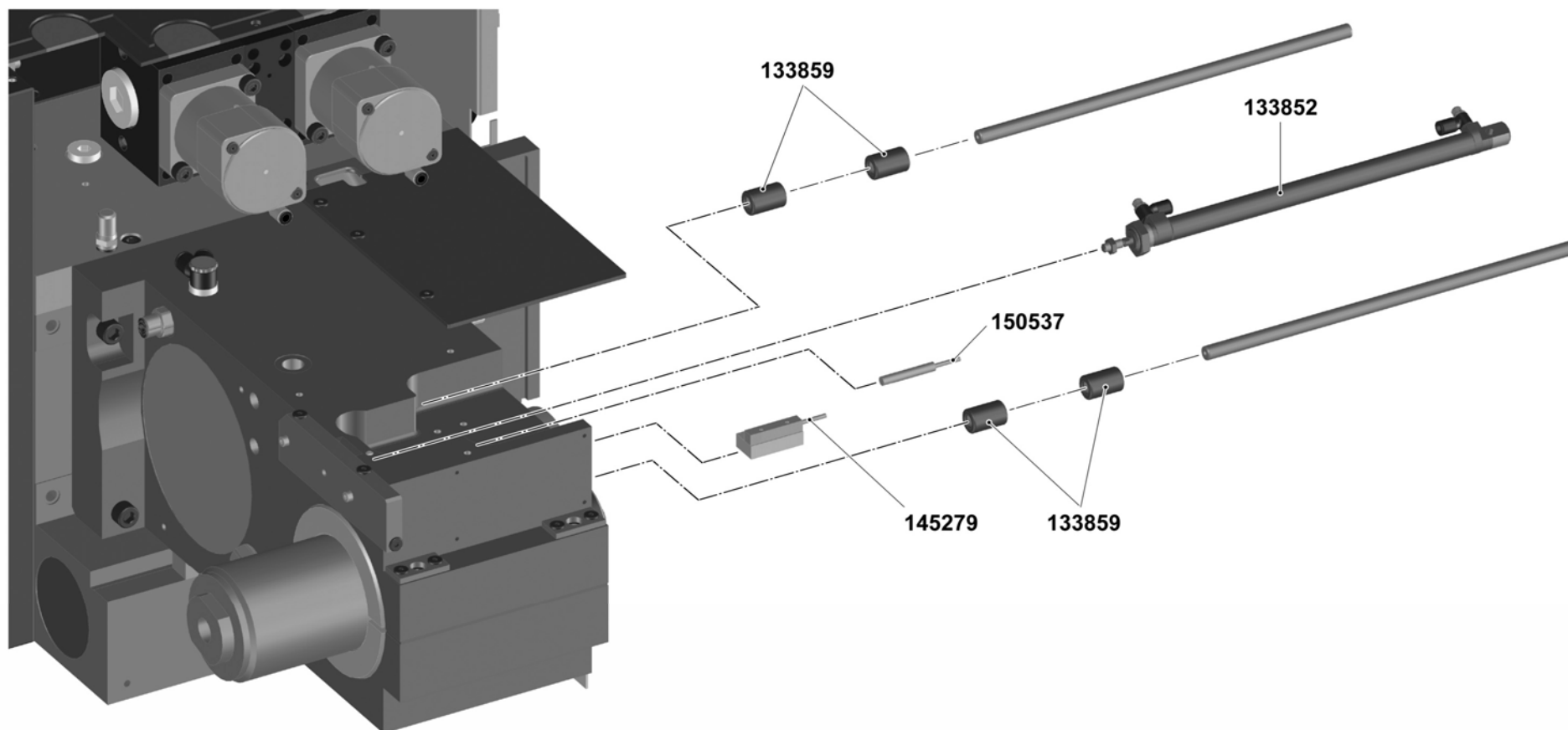

Schleifkopf Innenschleifen HF / Poupée porte-meule rectification intérieure HF / Wheelhead I.D. grinding HF

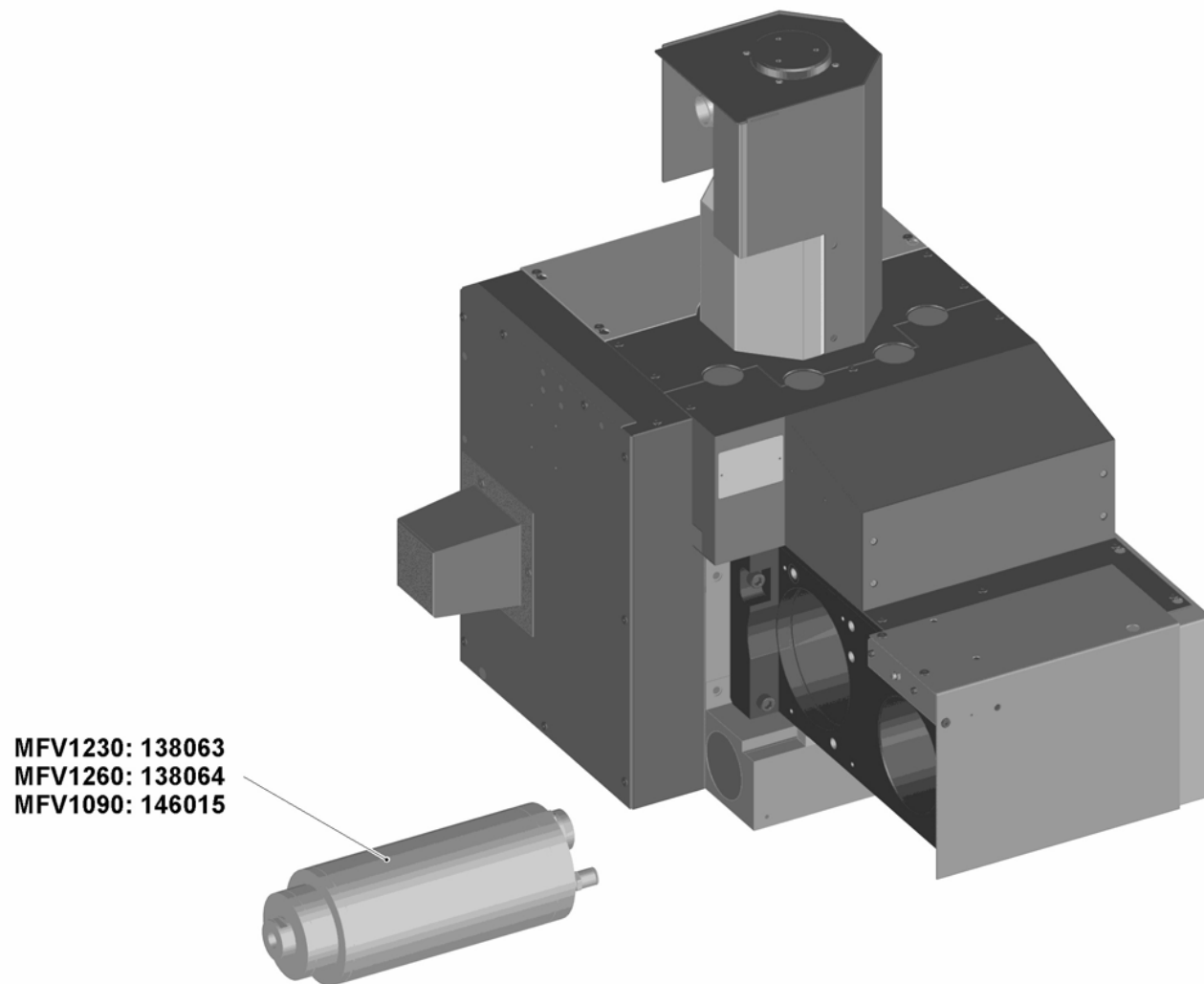

Öl/Luft – Schmieraggregat / Groupe de graissage huile/air / Oil/air lubrication unit

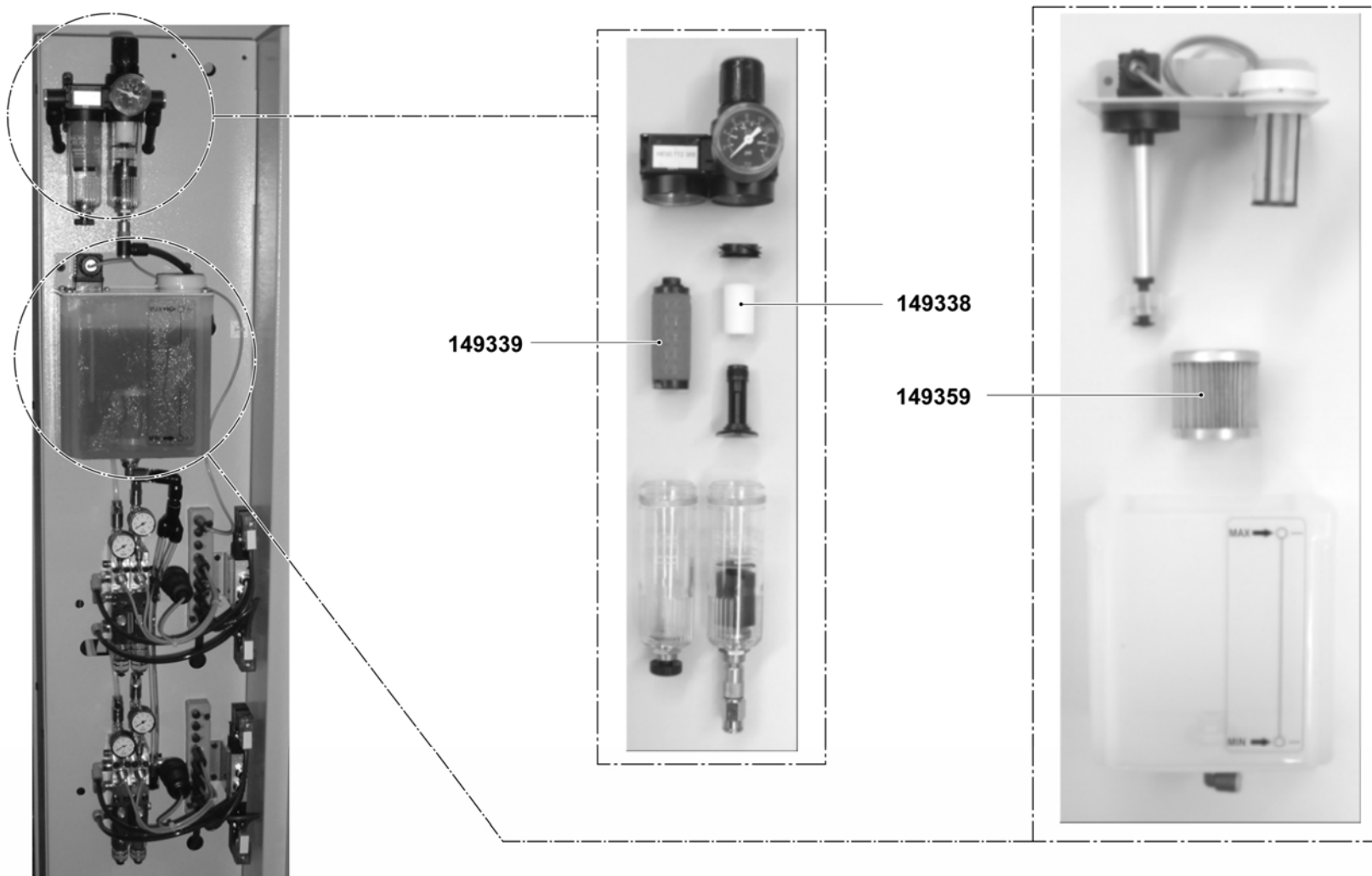

293368-1/1

Hydraulik Hydrostatik / Hydraulique hydrostatique / Hydraulics hydrostatics

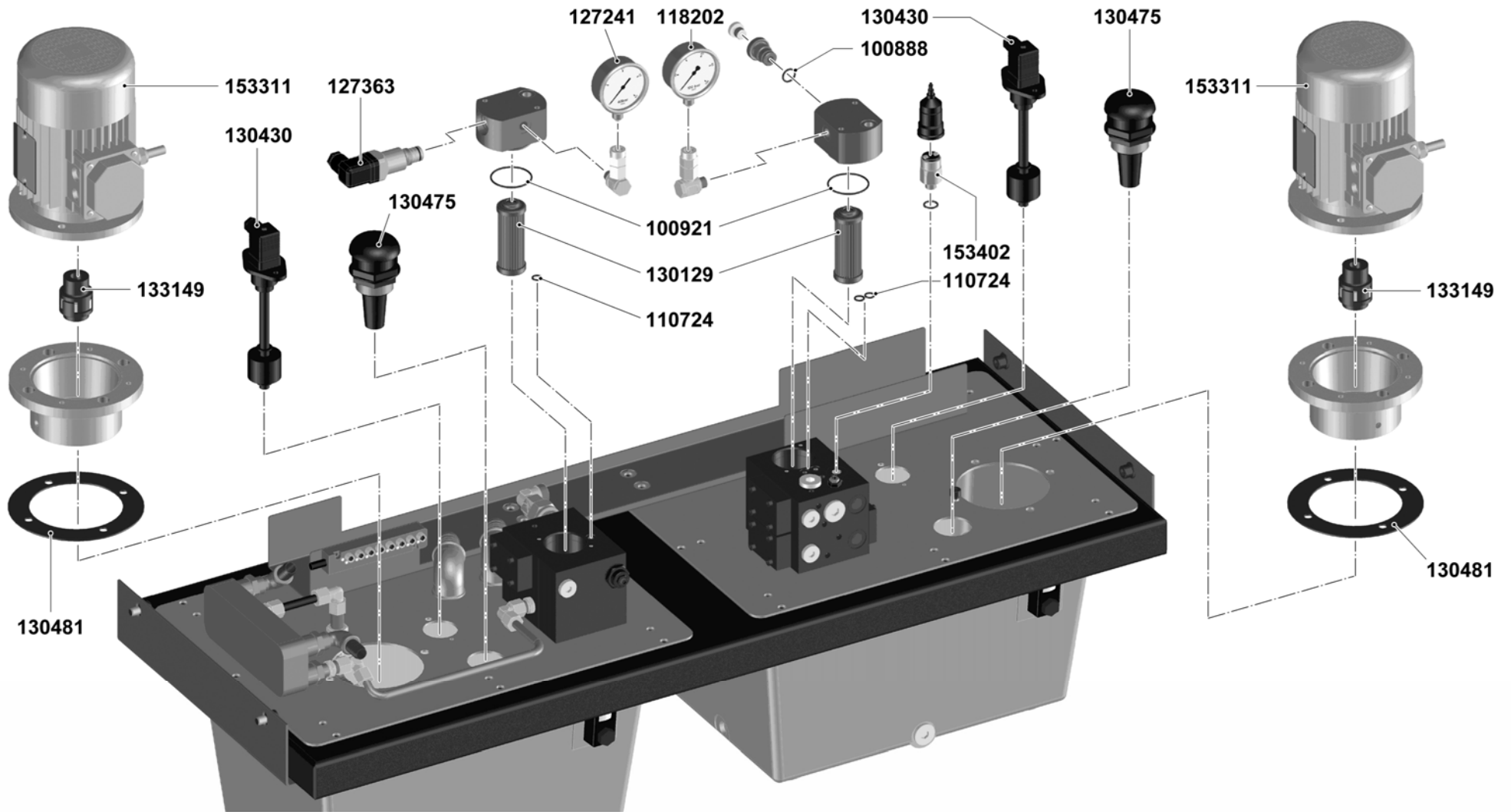

Hydraulik Hydrostatik / Hydraulique hydrostatique / Hydraulics hydrostatics

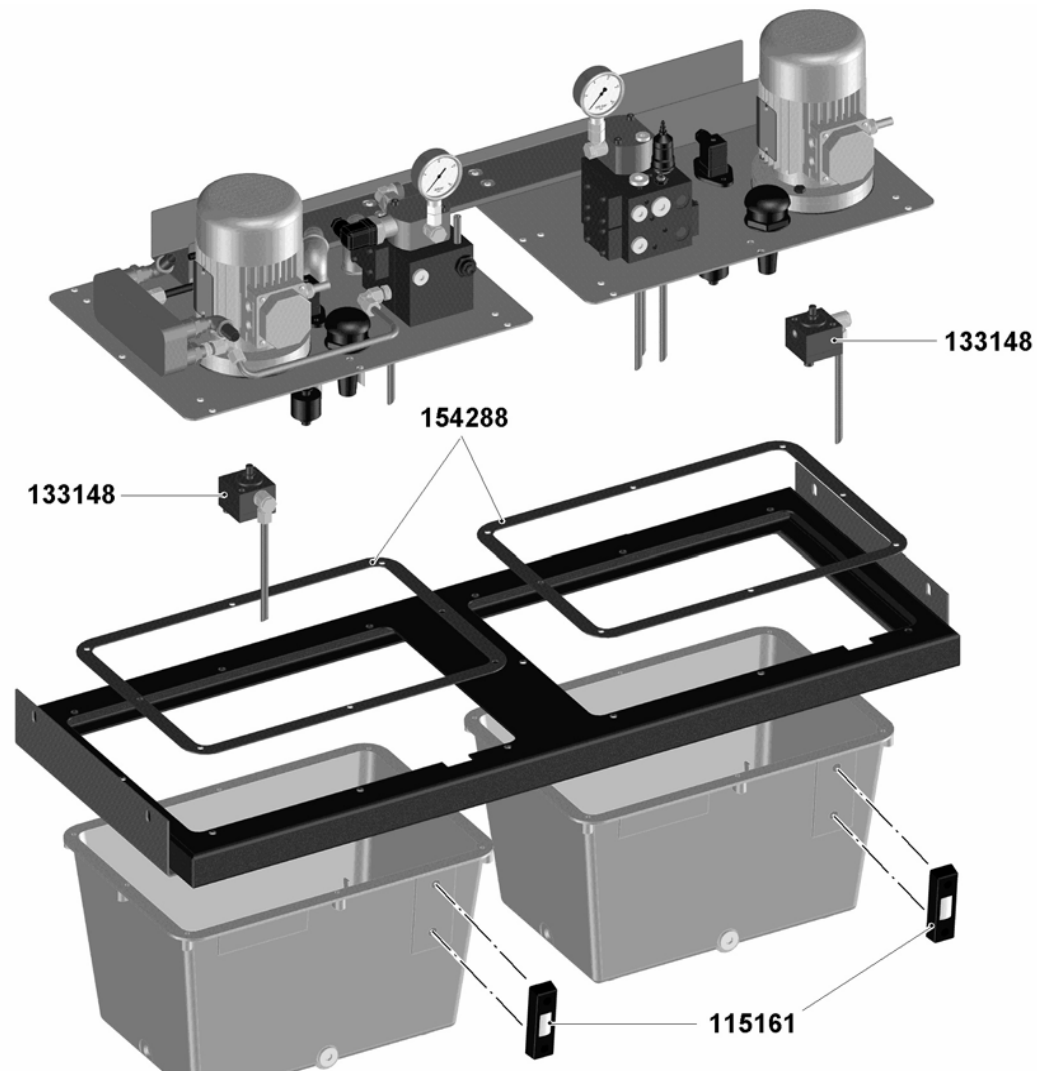

Pneumatik / Système pneumatique / Pneumatic system

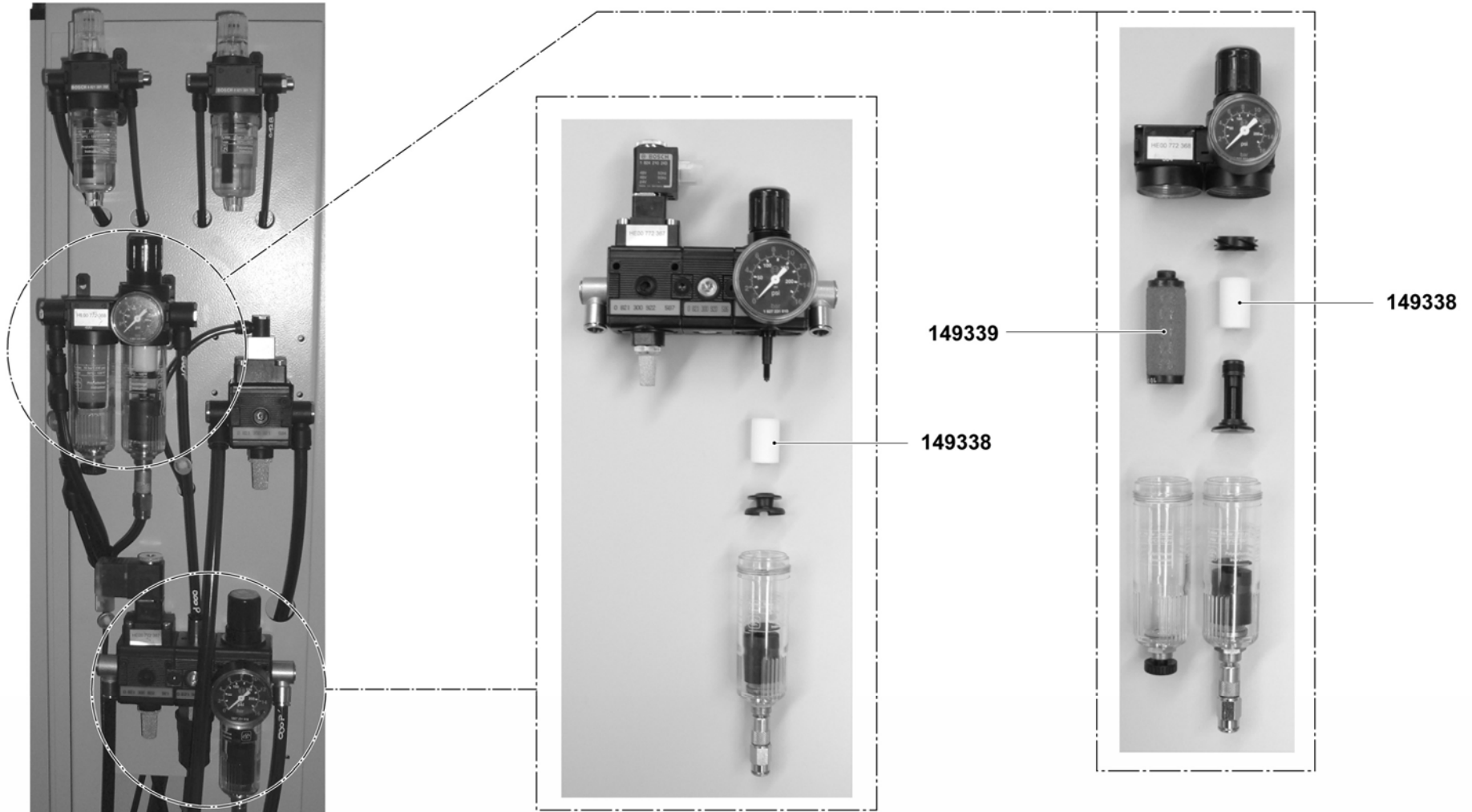

Panel / Panneau / Panel

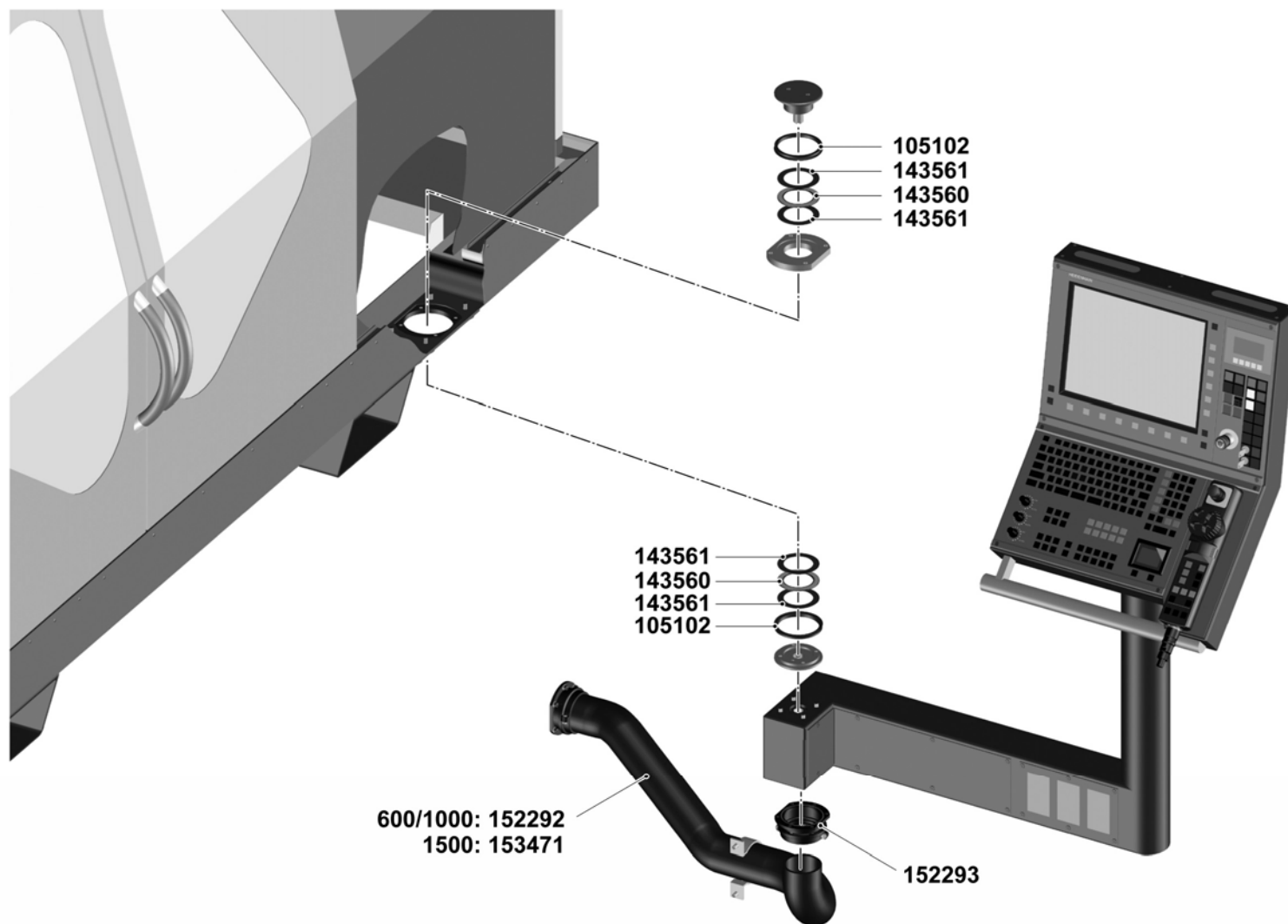

Steuerung / Commande / Control

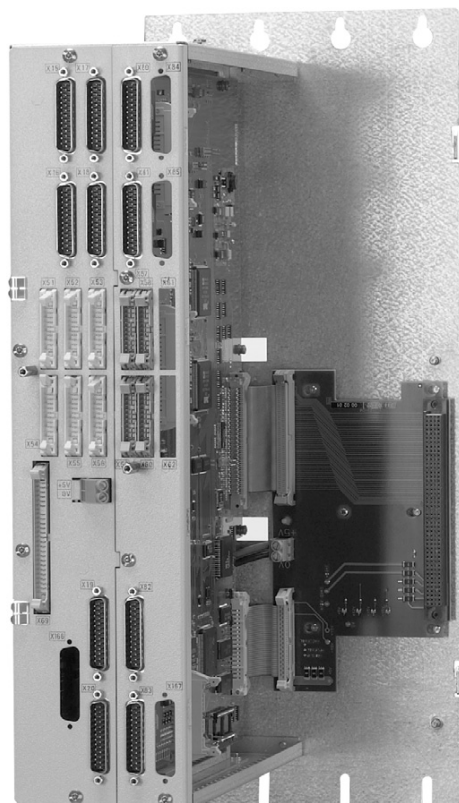

I56200

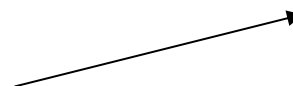

Kühlschmiermittelzuführung durch Werkstückspindel / Amenée du lubrifiant de refroidissement à travers la broche porte-pièce / Coolant-lubricant supply via the work spindle

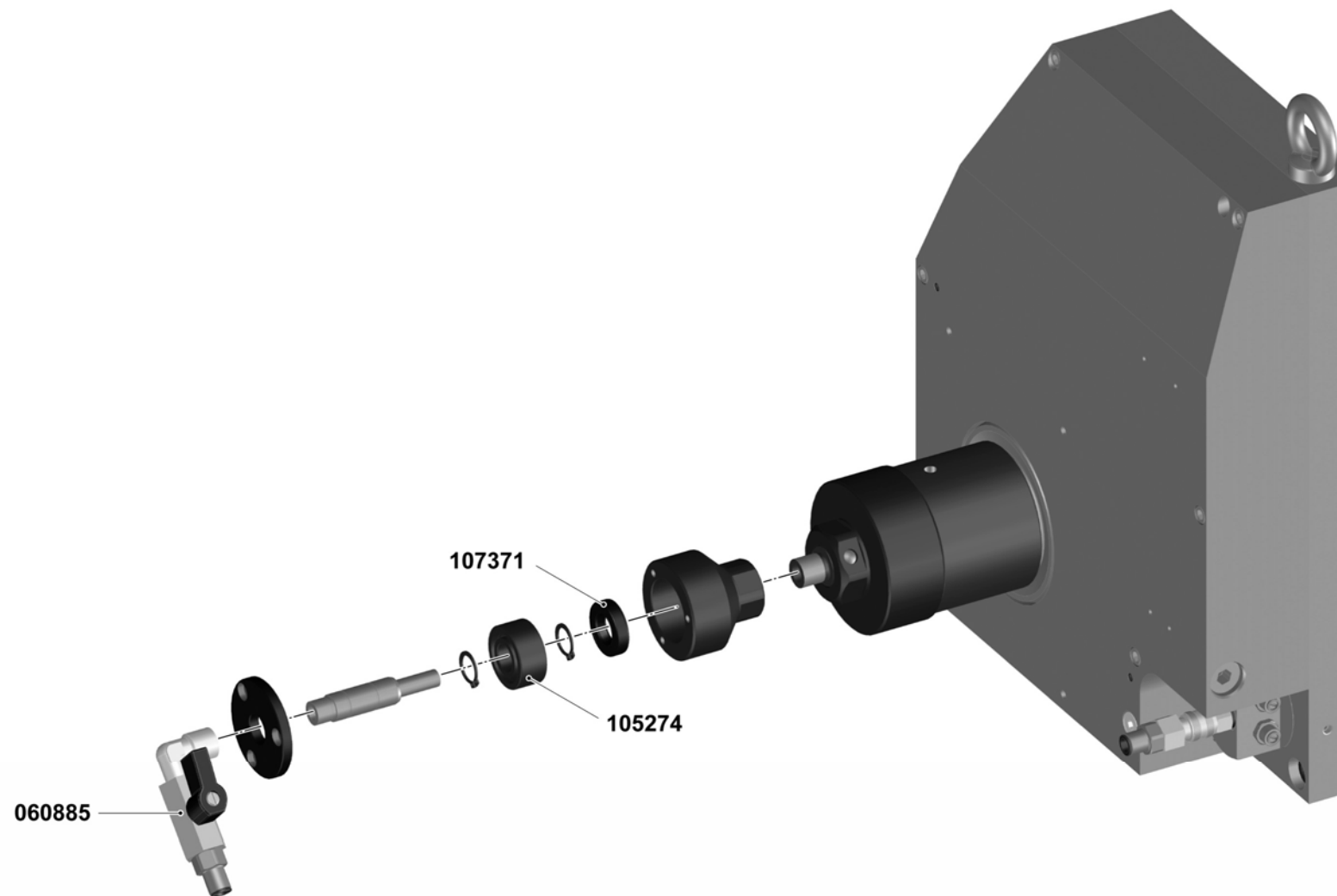

293358-1/1

Verschaltung / Capotage / Cabinet

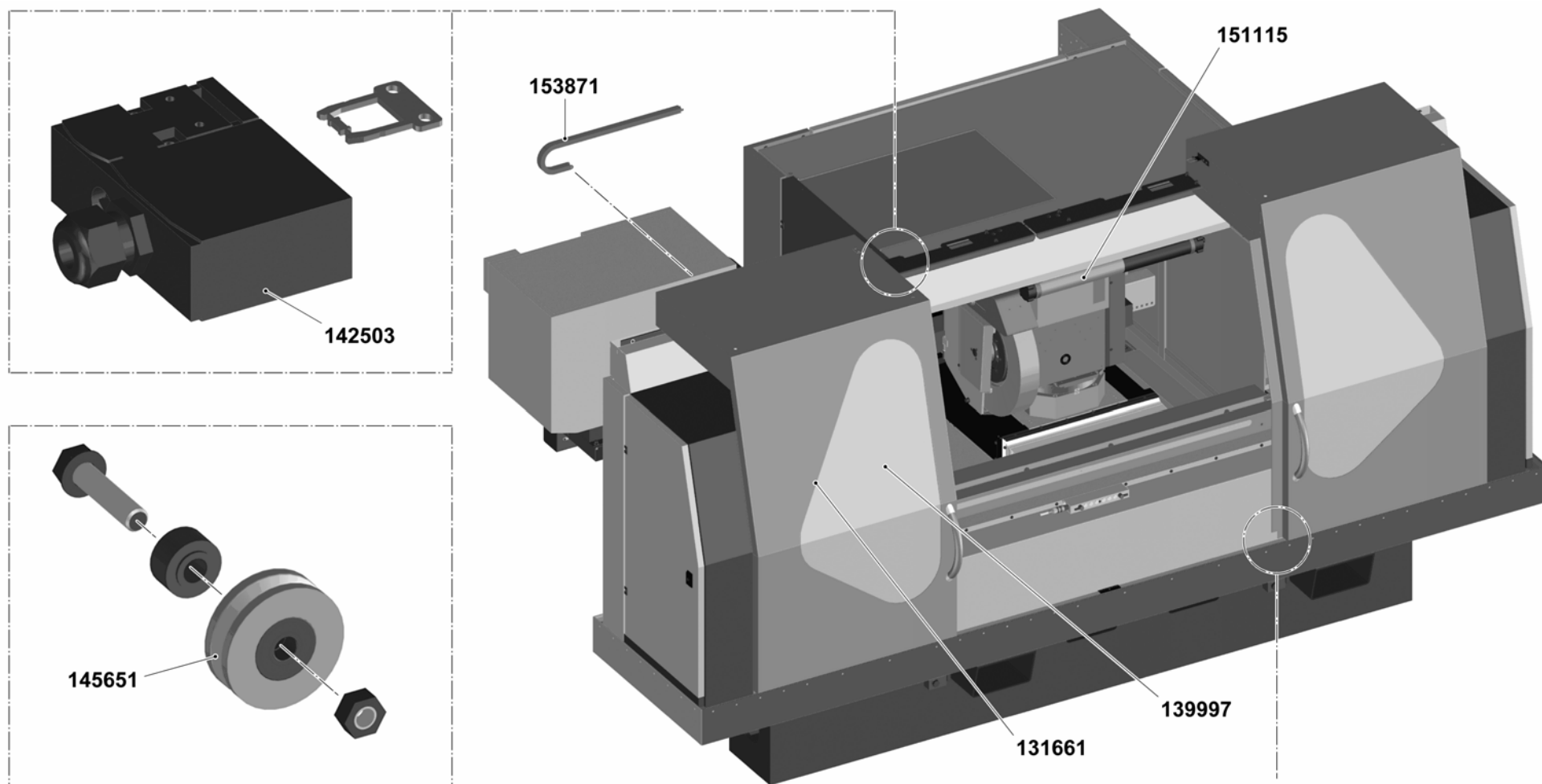

293344-1/1

Verschaltung elektrischer Schiebetürantrieb / Capotage entraînement électrique des portes coulissantes / Cabinet electric sliding door drive

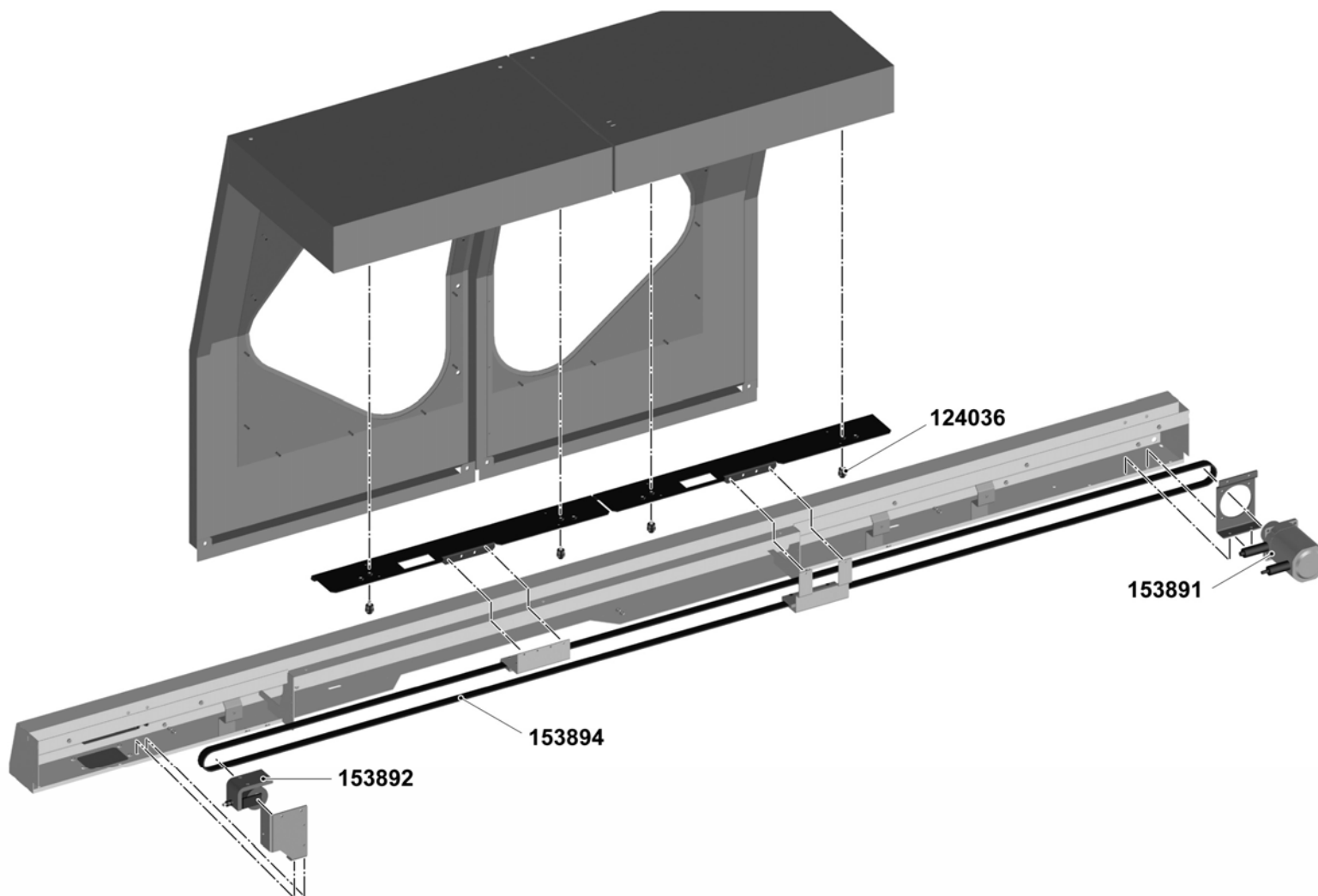

Werkstückspindelstock Standard / Poupée porte-pièce standard / Standard workhead

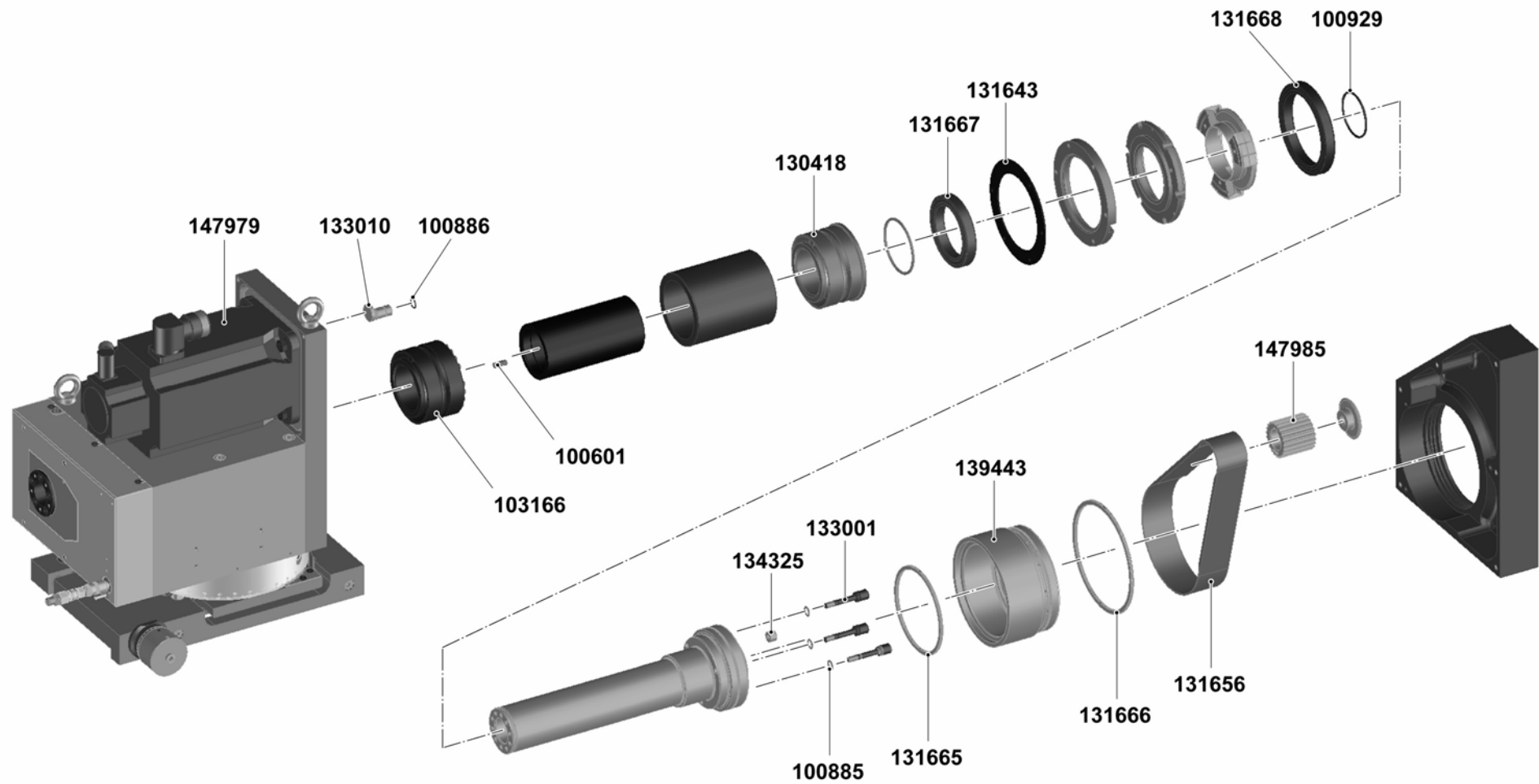

293340-1/6

Werkstückspindelstock Standard / Poupée porte-pièce standard / Standard workhead

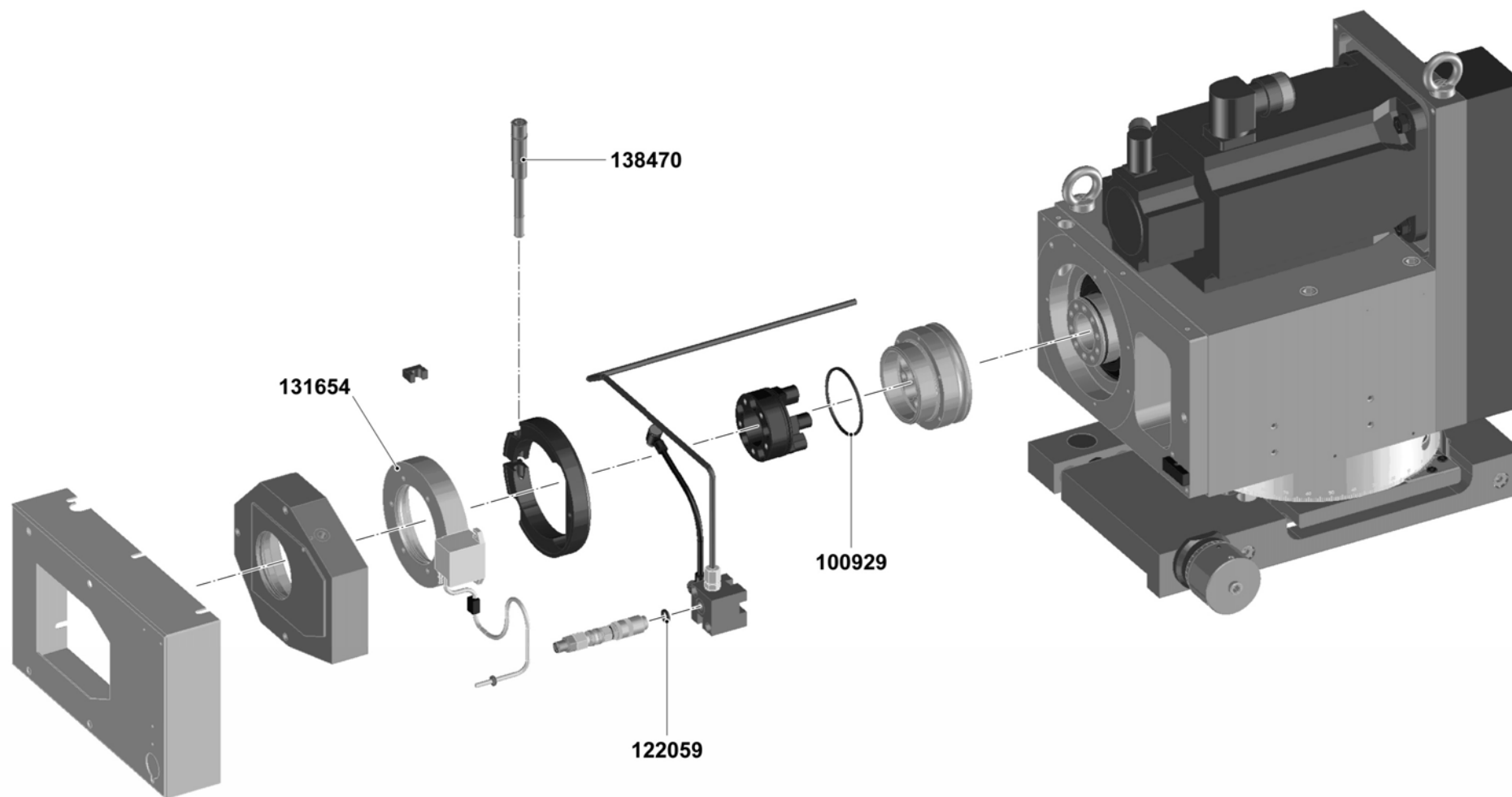

293340-2/6

Werkstückspindelstock Grobverstellung / Poupée porte-pièce ajustage approximatif / Workhead coarse infeed

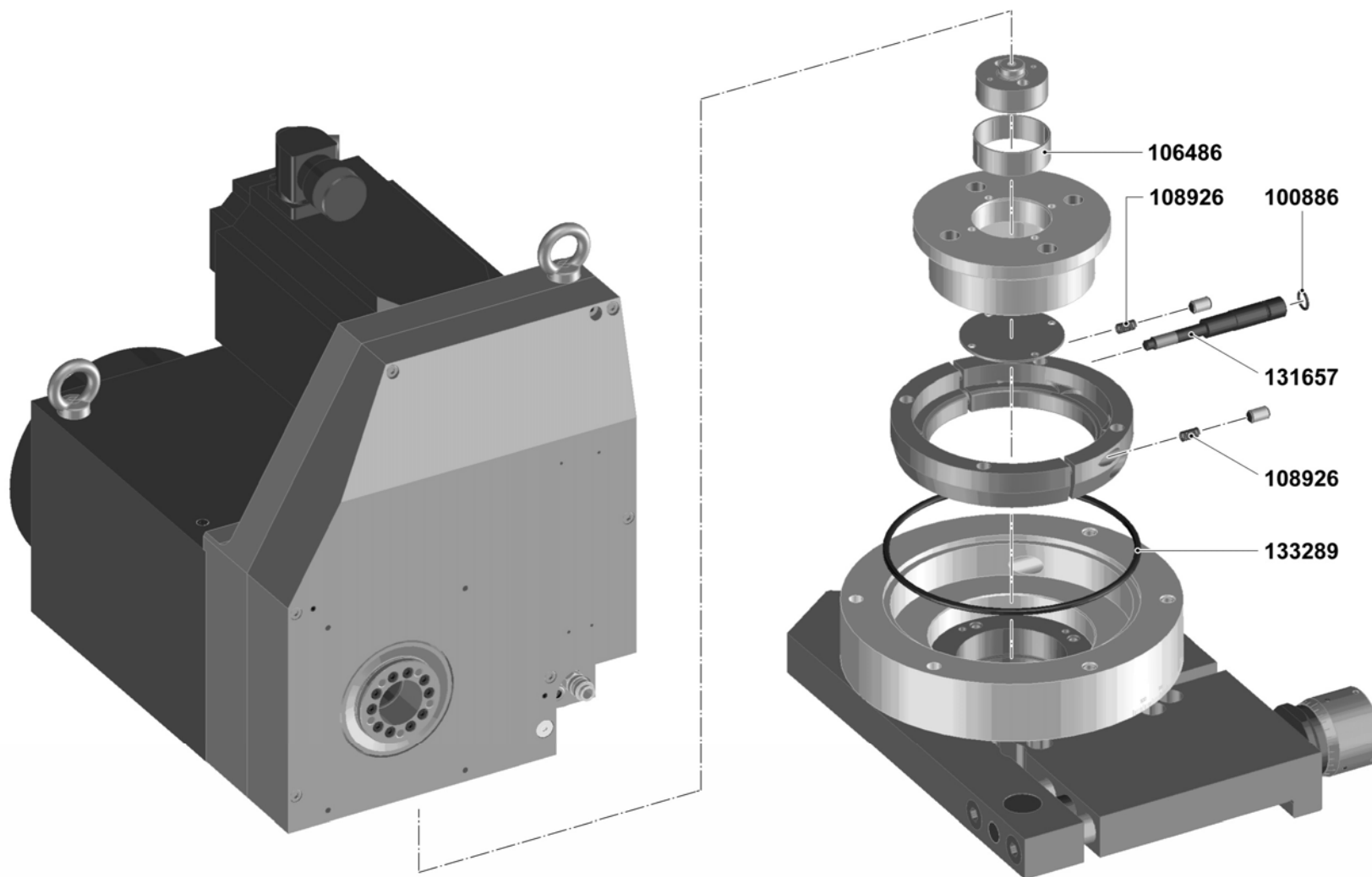

293340-3/6

Werkstückspindelstock Feinverstellung / Poupée porte-pièce ajustage fin / Workhead coarse fine

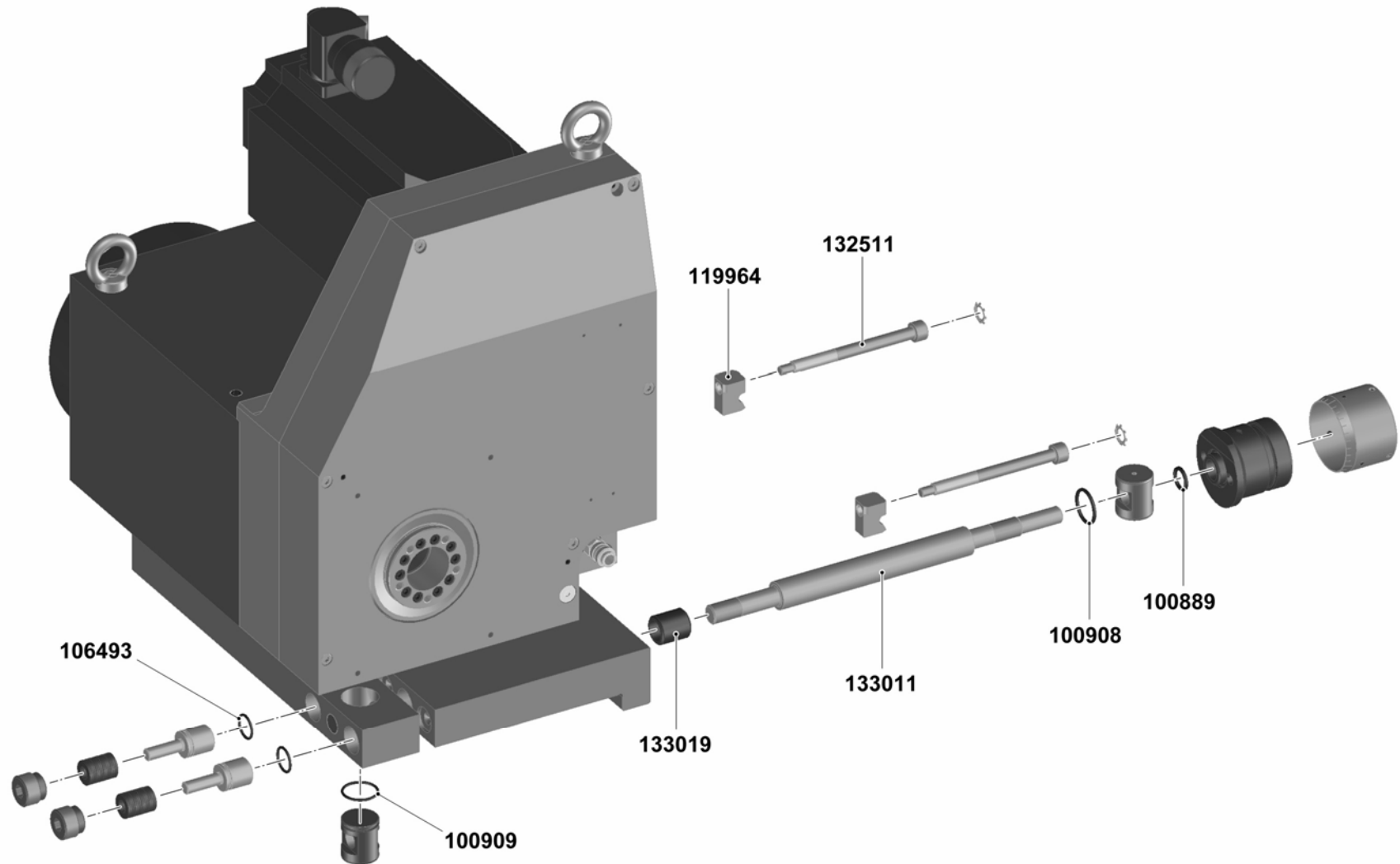

Werkstückspindelstock verstärkt / Poupée porte-pièce renforcée / Reinforced workhead

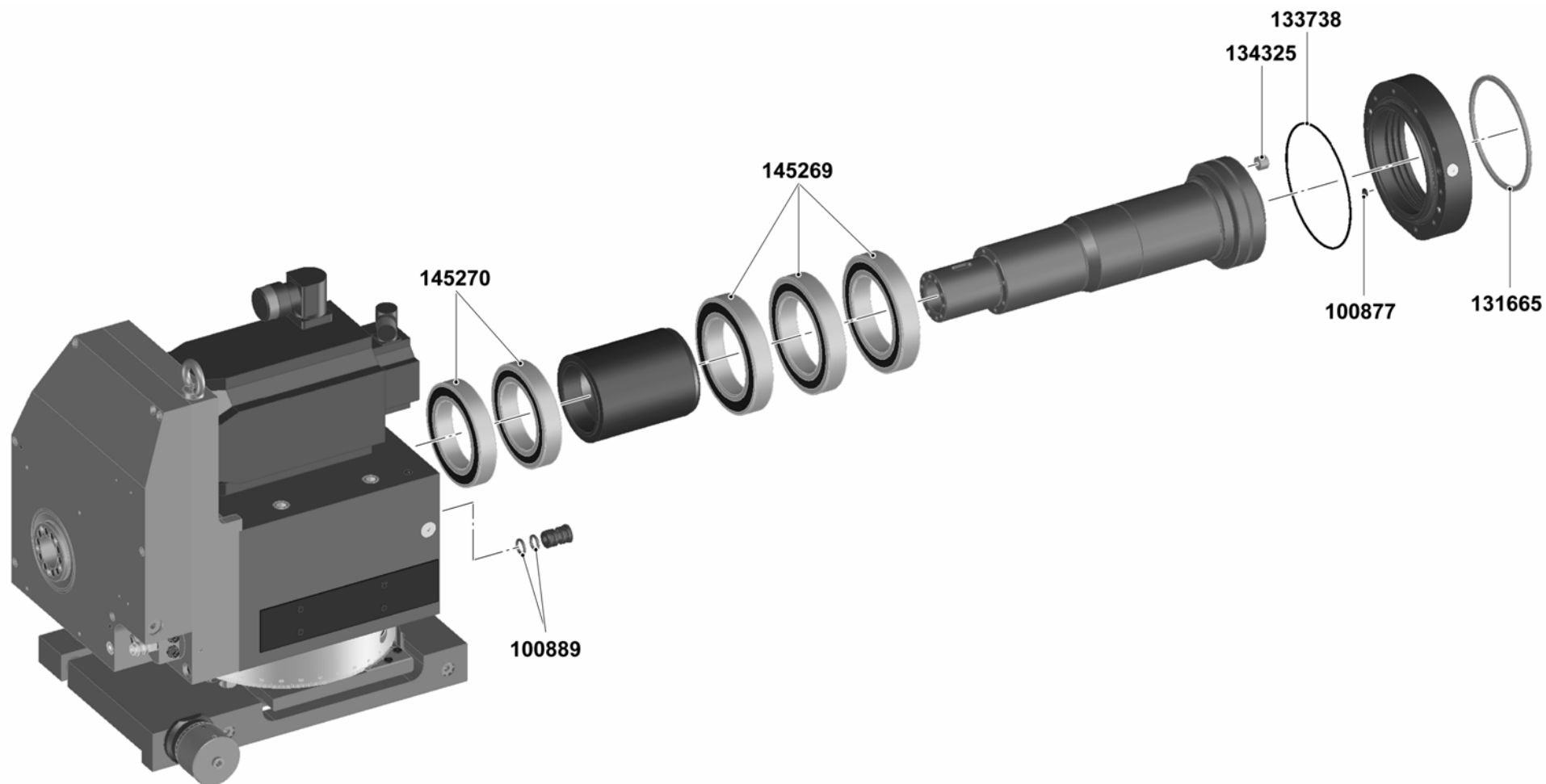

293340-5/6

Werkstückspindelstock verstärkt / Poupée porte-pièce renforcée / Reinforced workhead

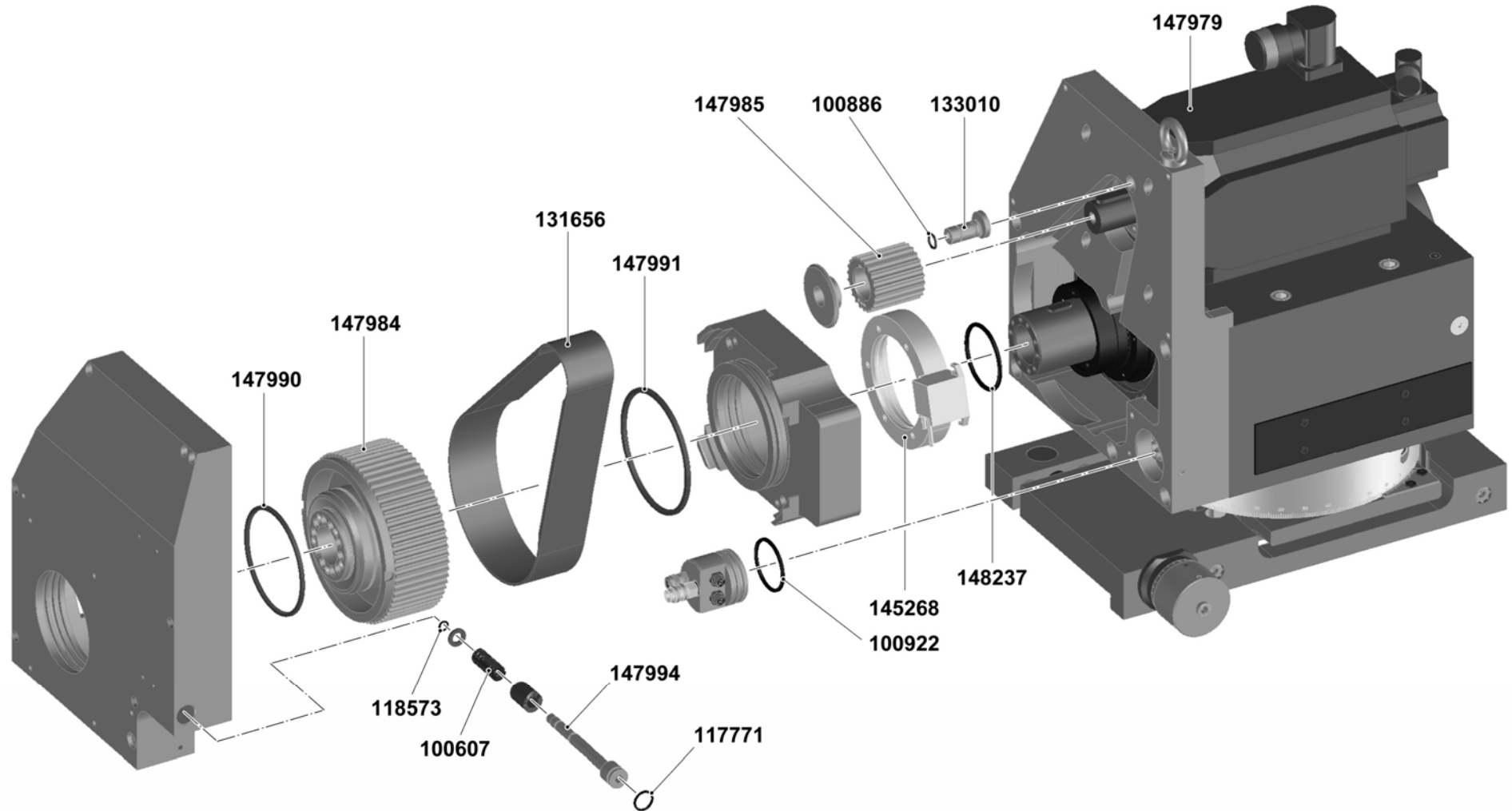

293340-6/6

Reitstock / Contre-poupée / Tailstock

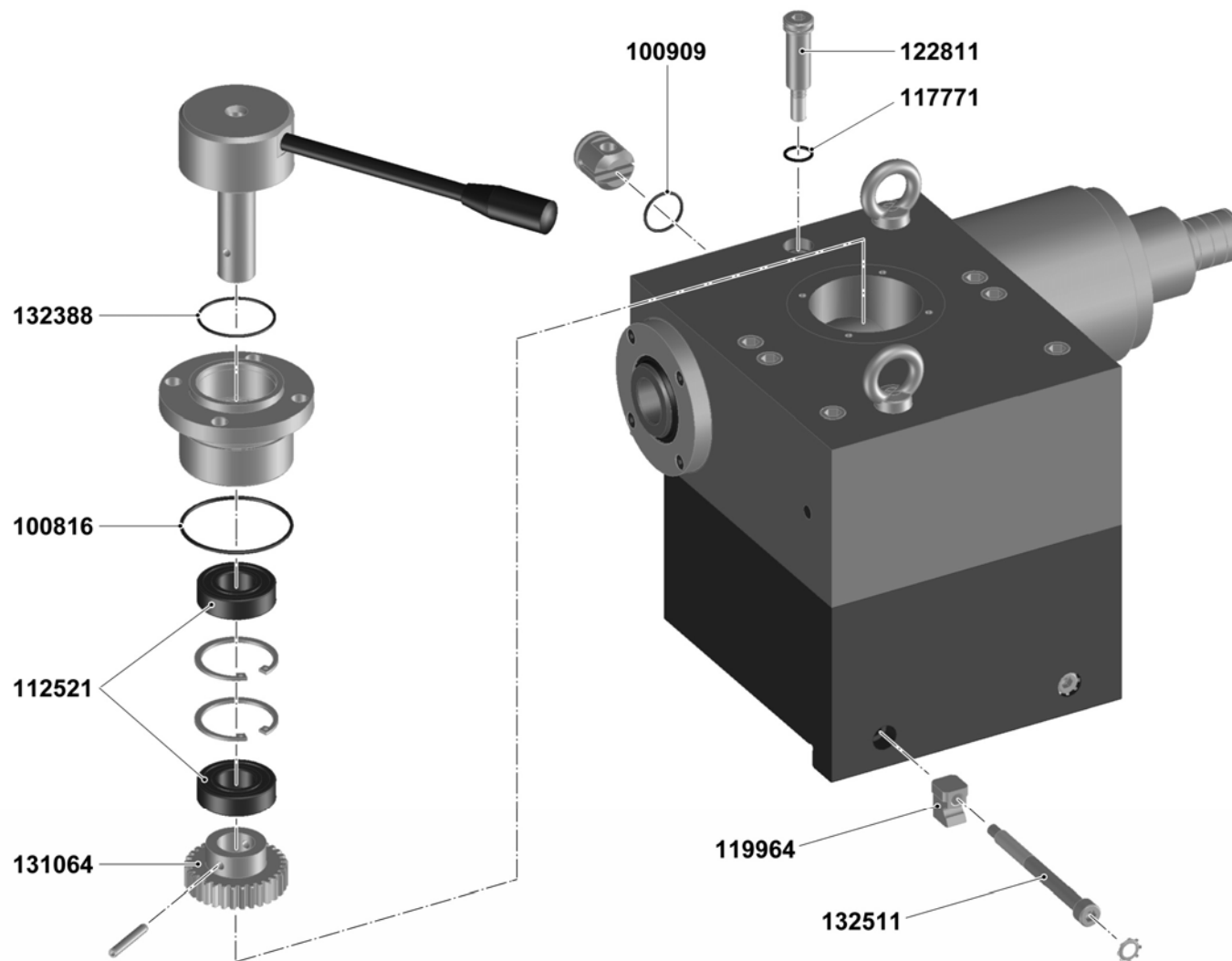

293339-1/4

Reitstock mit Hydraulikrückzug / Contre-poupée avec rétraction hydraulique / Tailstock with hydraulic sleeve retraction

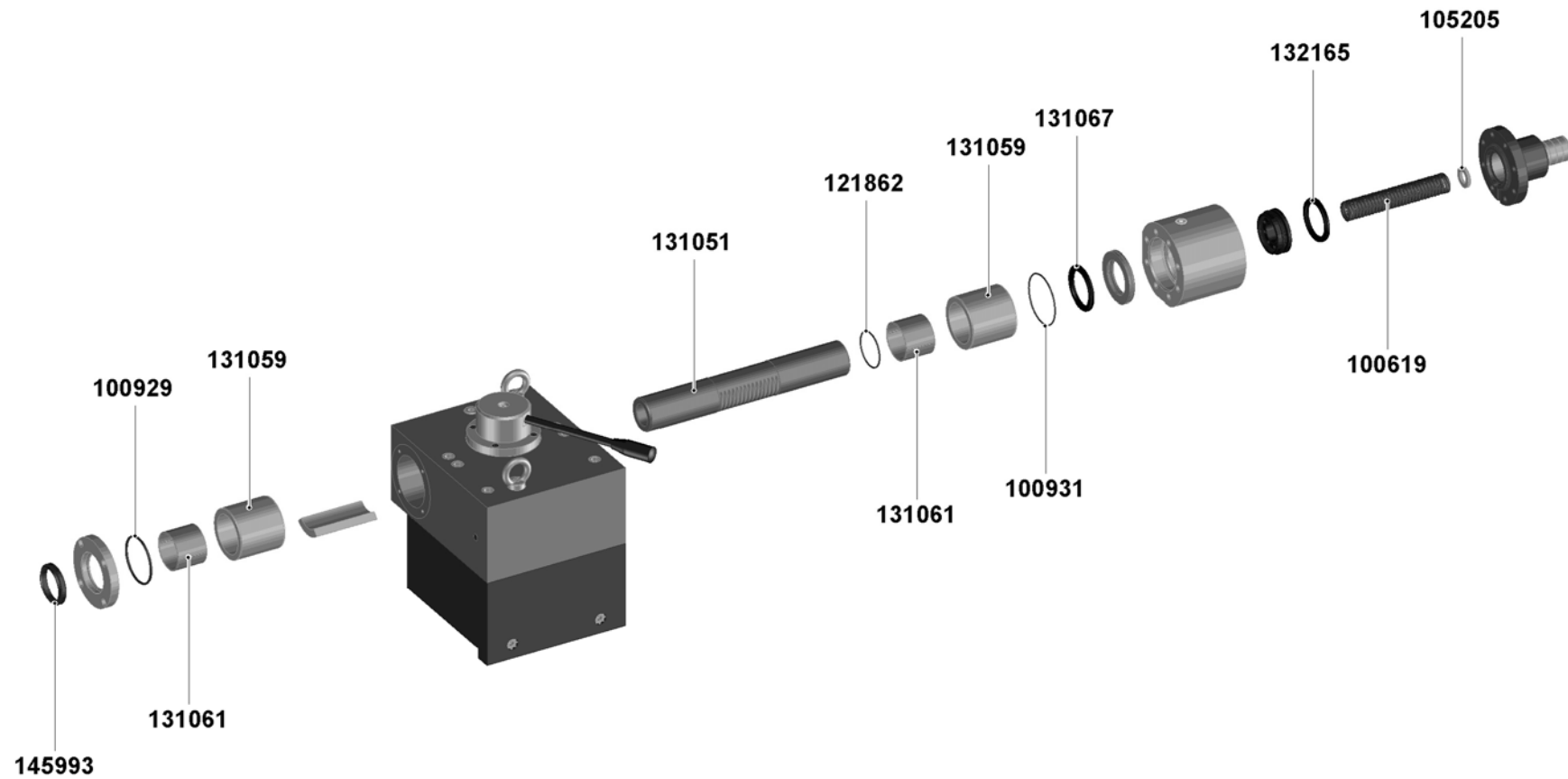

293339-2/4

Reitstock mit Pneumatikrückzug / Contre-poupée avec rétraction pneumatique / Tailstock with pneumatic sleeve retraction

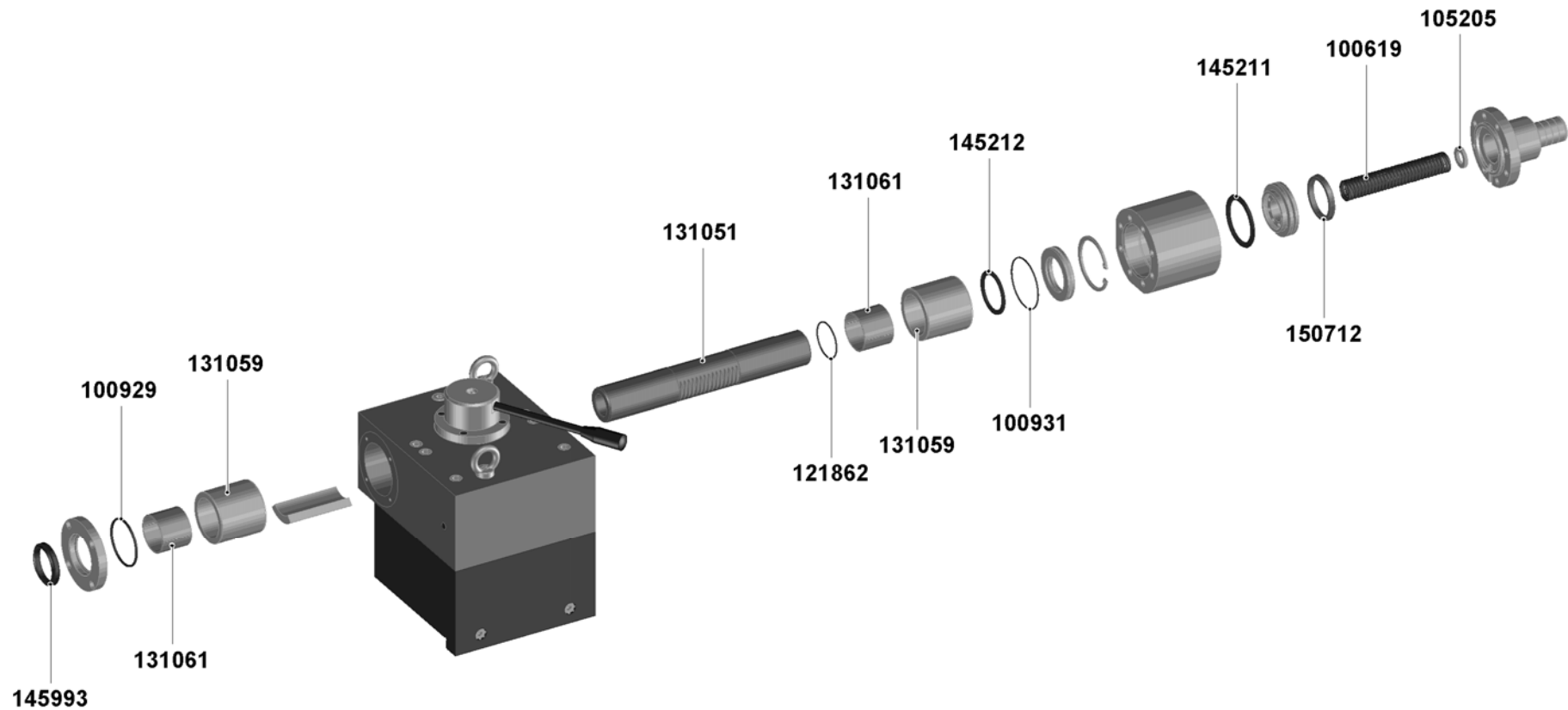

293339-3/4

Reitstock Feinverstellung / Contre-poupée ajustage fin / Tailstock fine infeed

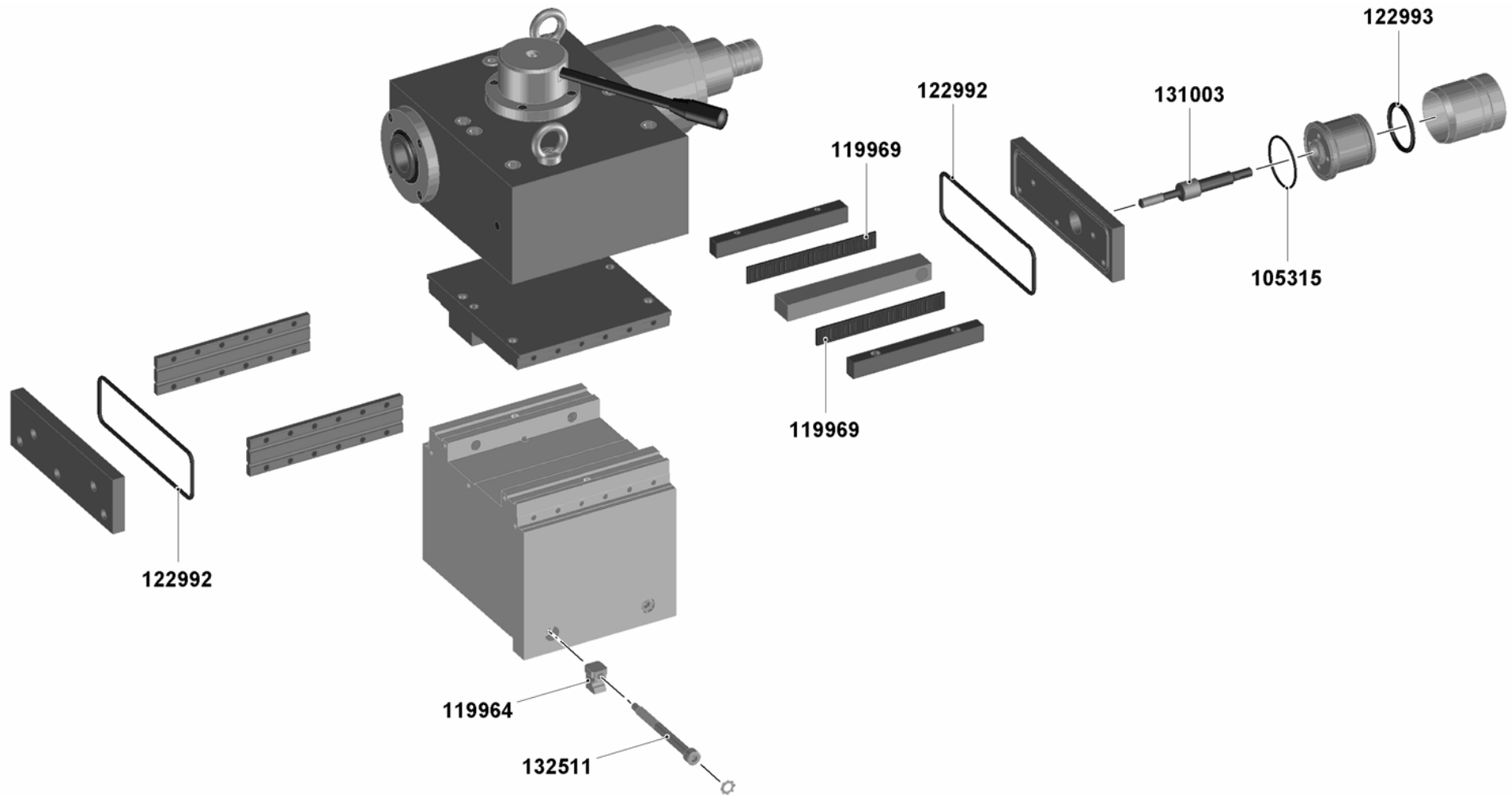

293339-4/4

Federnde Reitstockspitze / Pointe à ressorts / Spring center

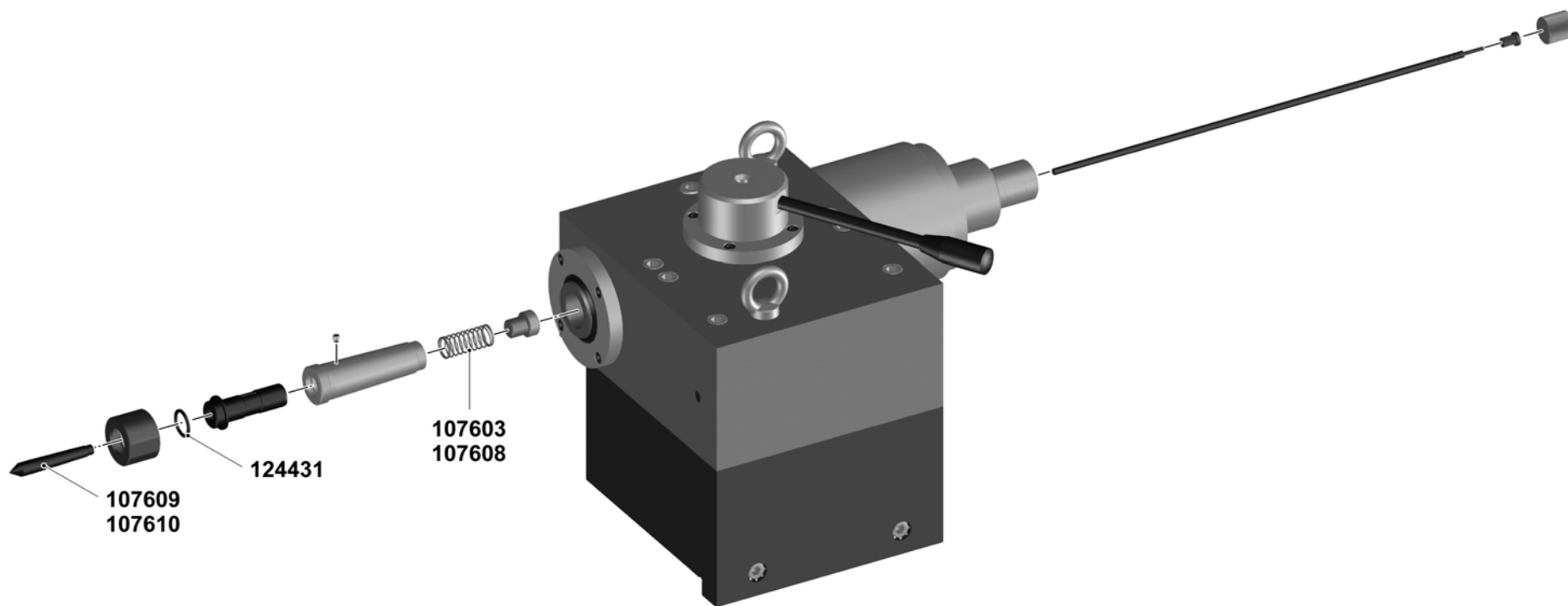

Zweibackenlunette / Lunette à deux mors / 2-jaw steady rest

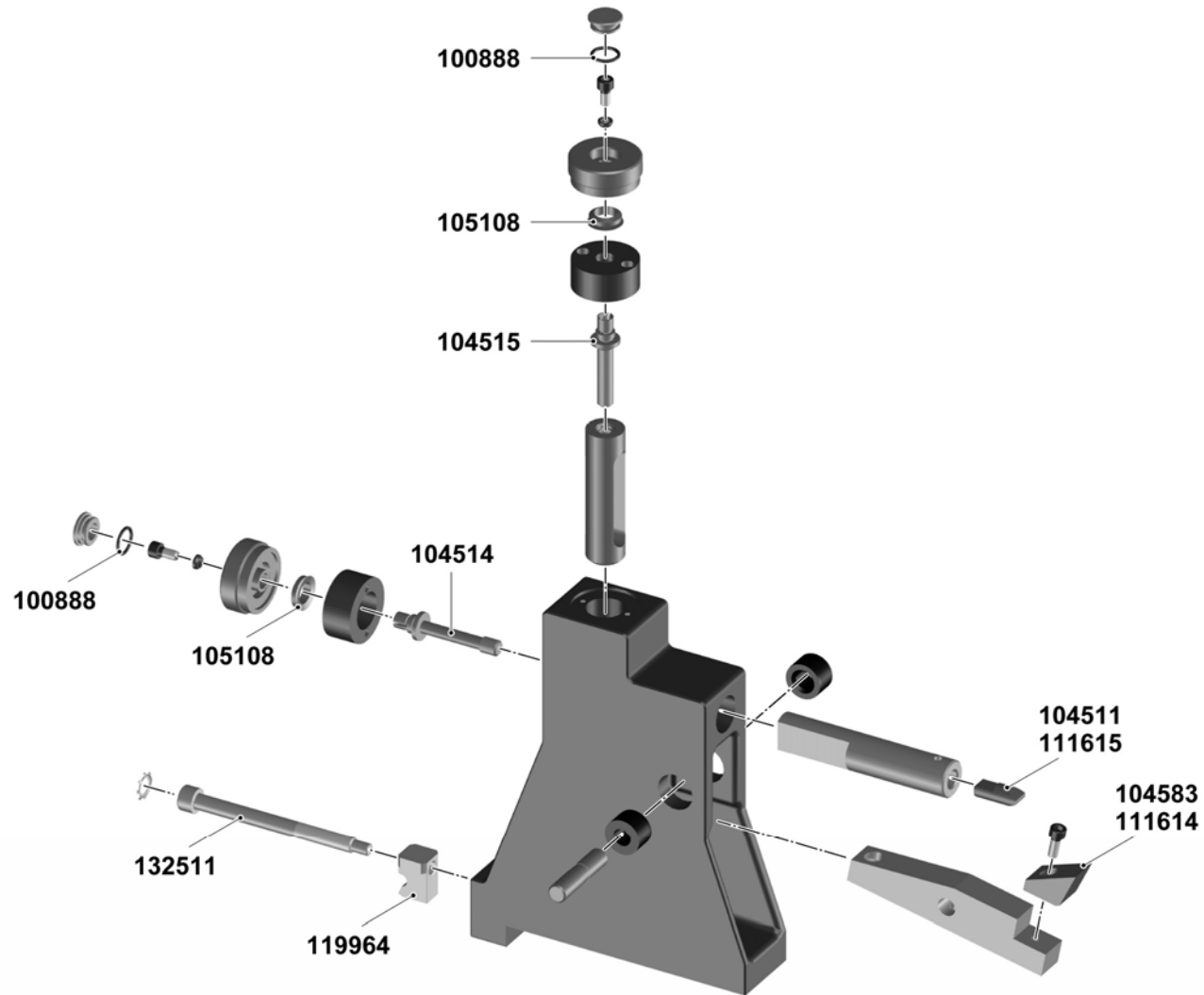

293362-1/1

Dreibackenlunette / Lunette à trois mors / 3-jaw steady rest

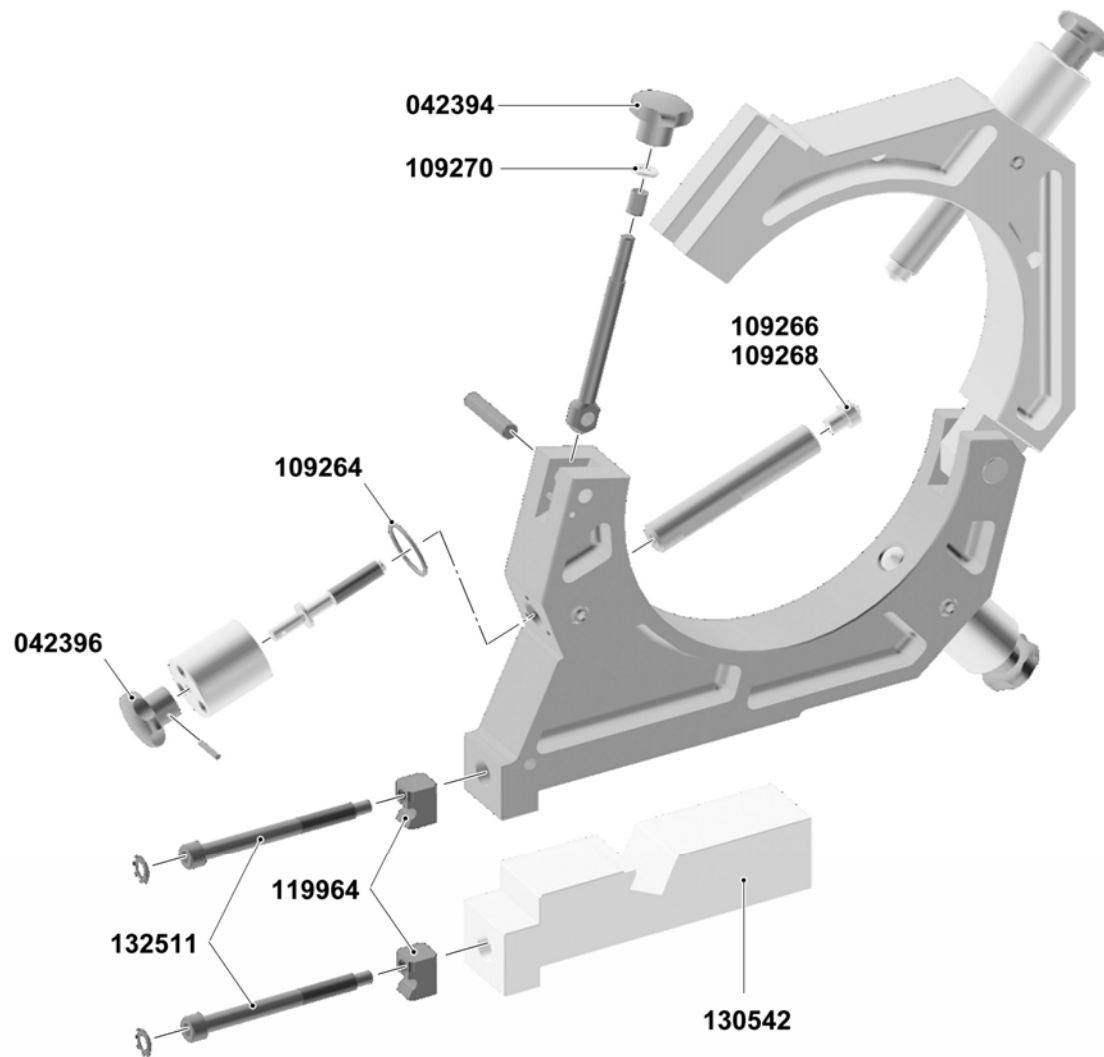

293363-1/1

Abrichtgerät auf Obertisch / Dispositif à dresser sur la table supérieure / Dressing device at the upper table

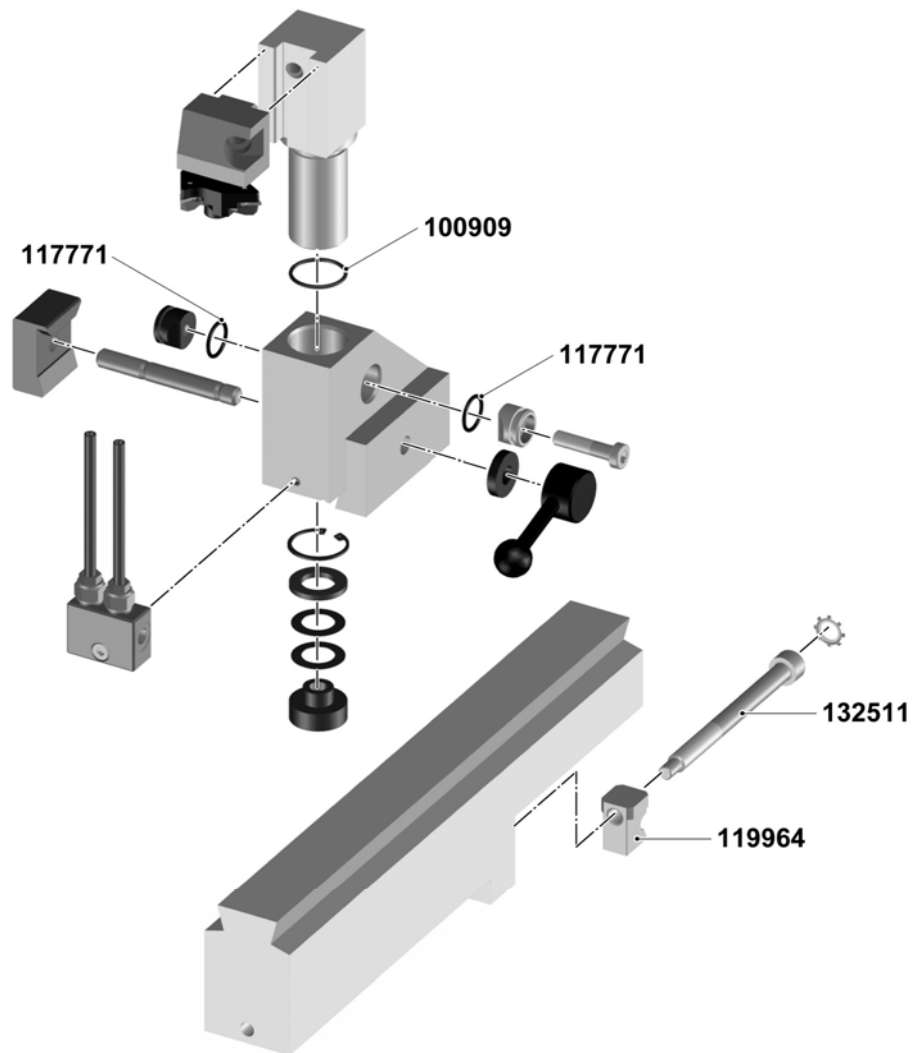

HF - Abrichtgerät auf Obertisch / Dispositif à dresser sur la table supérieure - HF / HF - Dressing device at the upper table

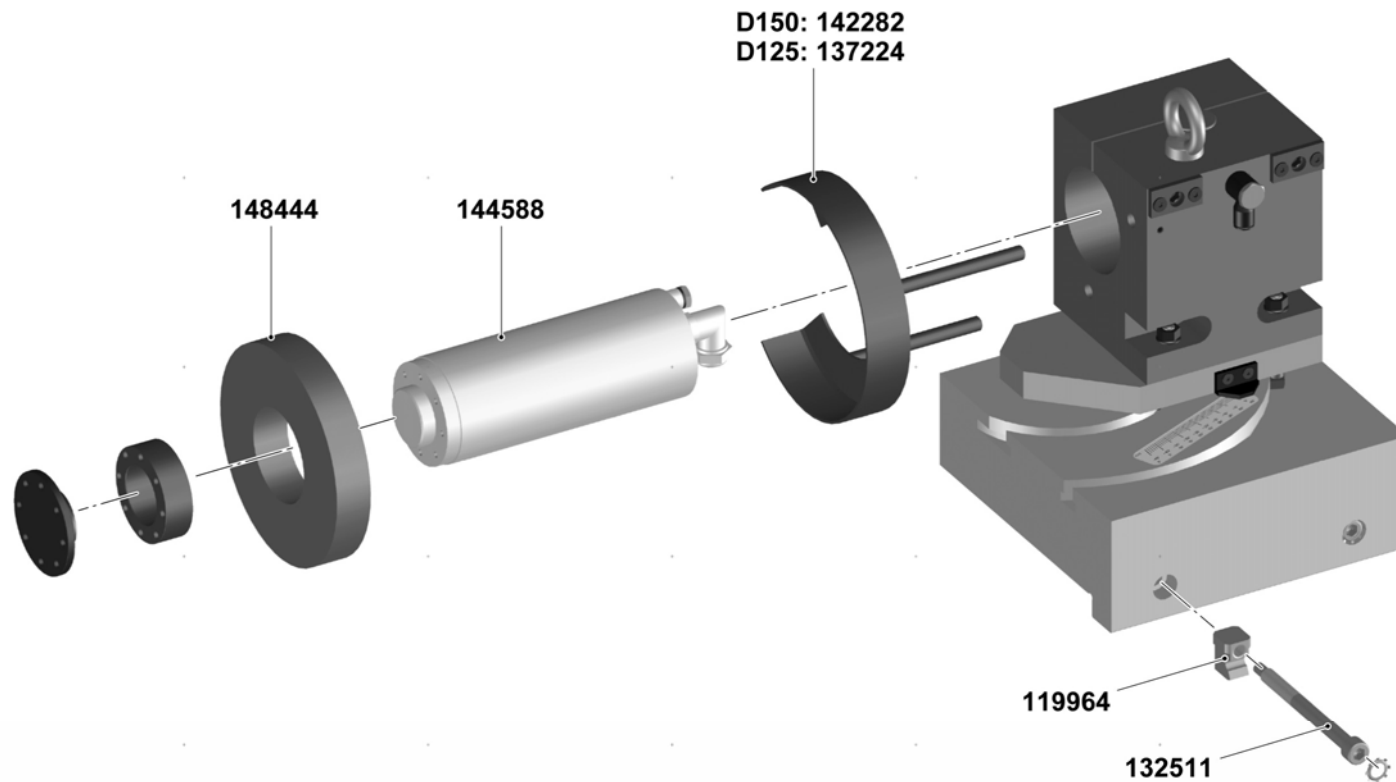

Werkzeugvermessungssystem KEL-SET / Système de mesure de meules KEL-SET / Tool measuring system KEL-SET

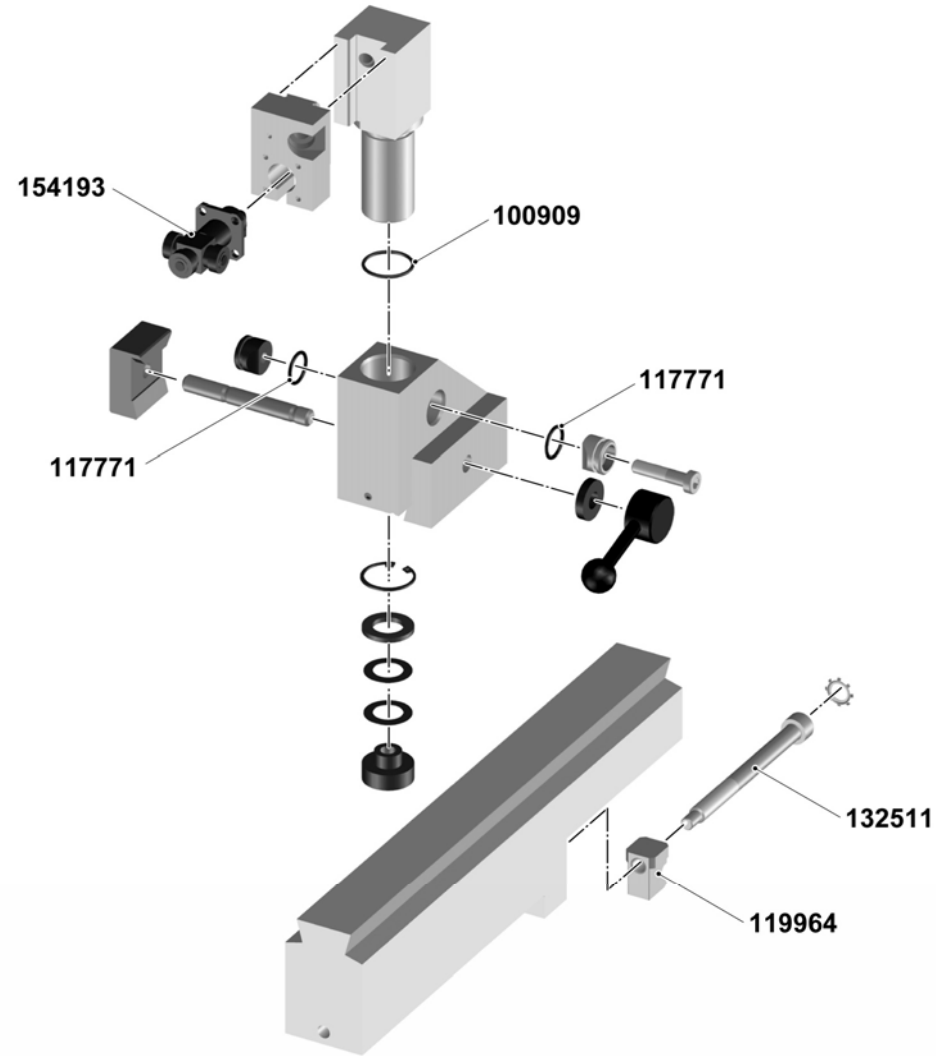

Aktive Längspositionierung KEL-POS / Système de positionnement actif KEL-POS / Active flagging device KEL-POS

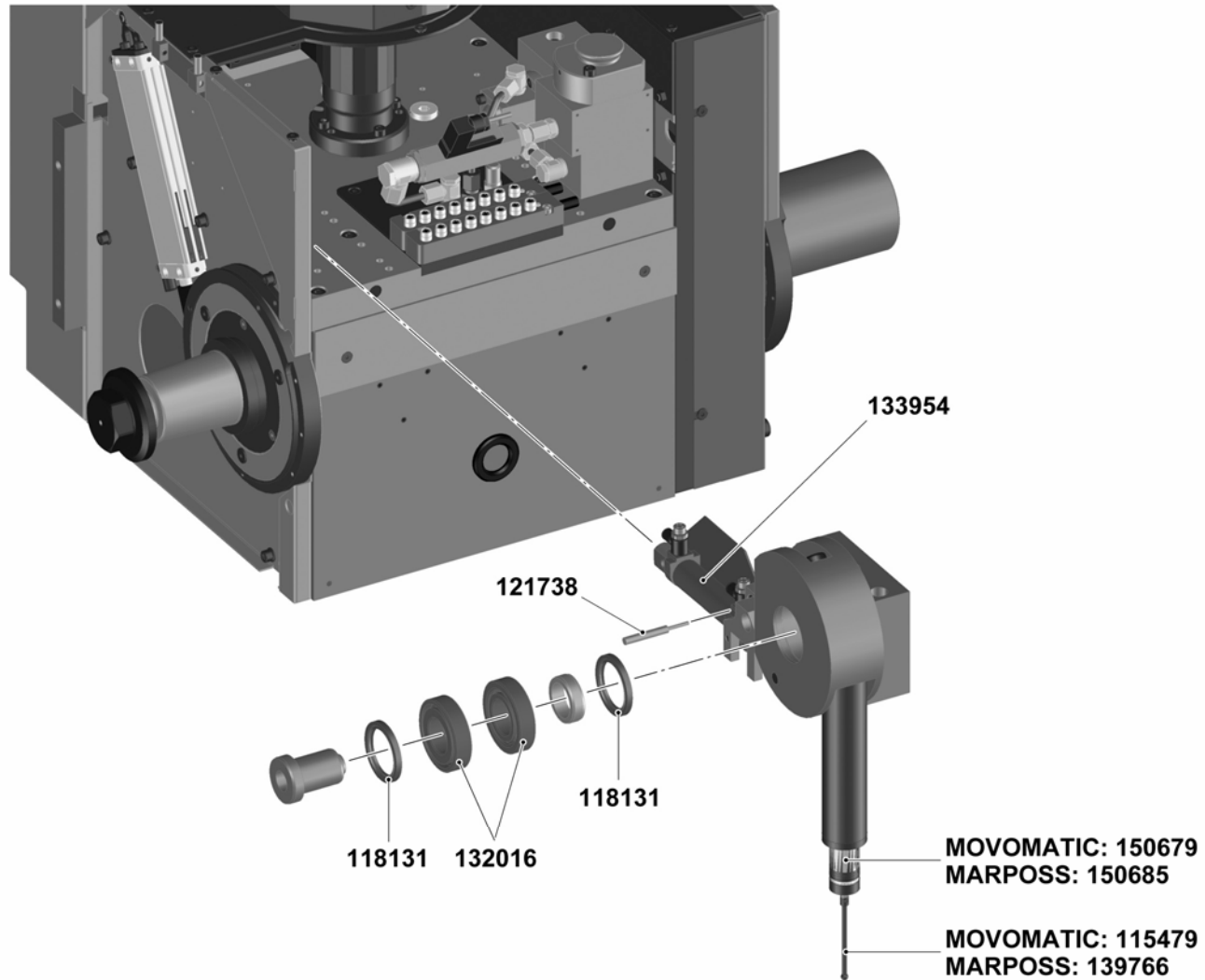

Messteuerung pneum. Pinolenrückzug / Autocalibrage rétraction pneum. de la contre-pointe / In-process gauge system pneumatic retraction

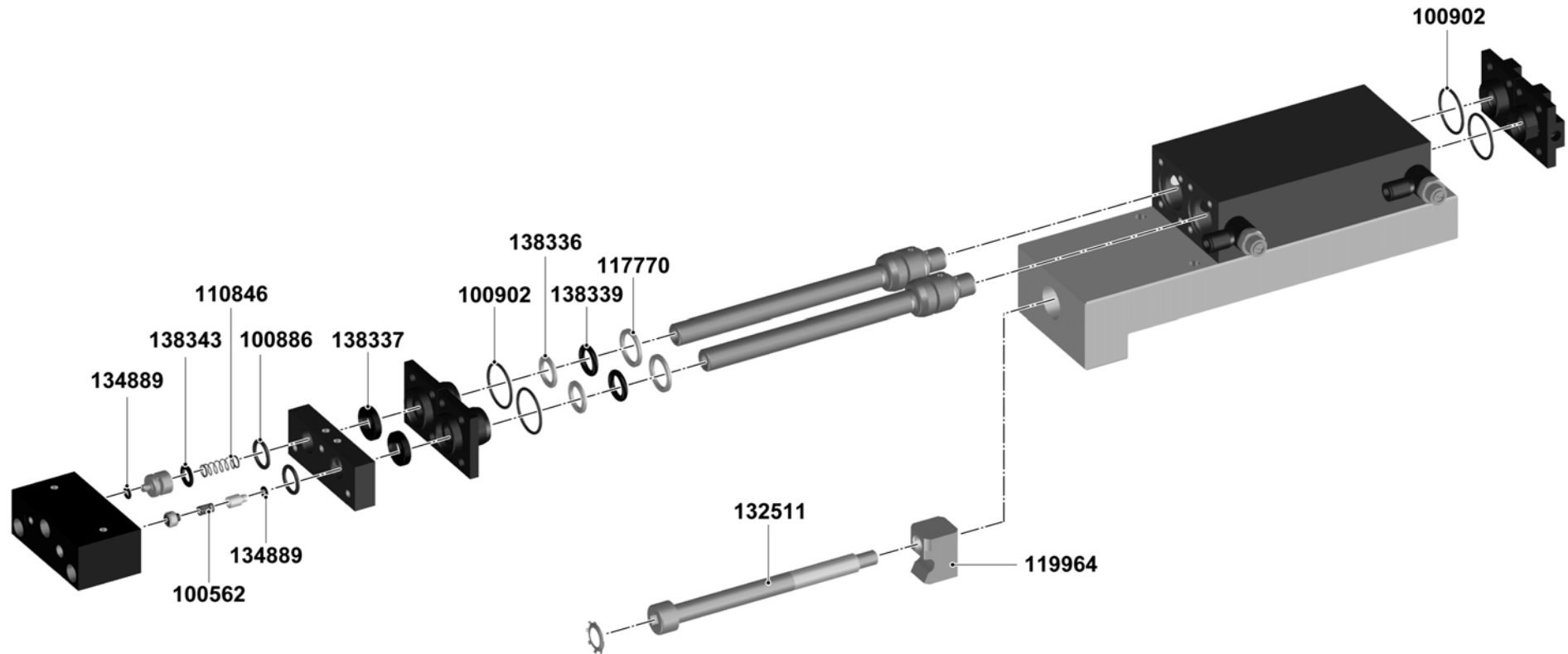

Schwenkwinkelanzeige Werkstückspindelstock / Affichage de l'angle d'orientation de la poupée porte-pièce / Swivel angle indicator for workhead

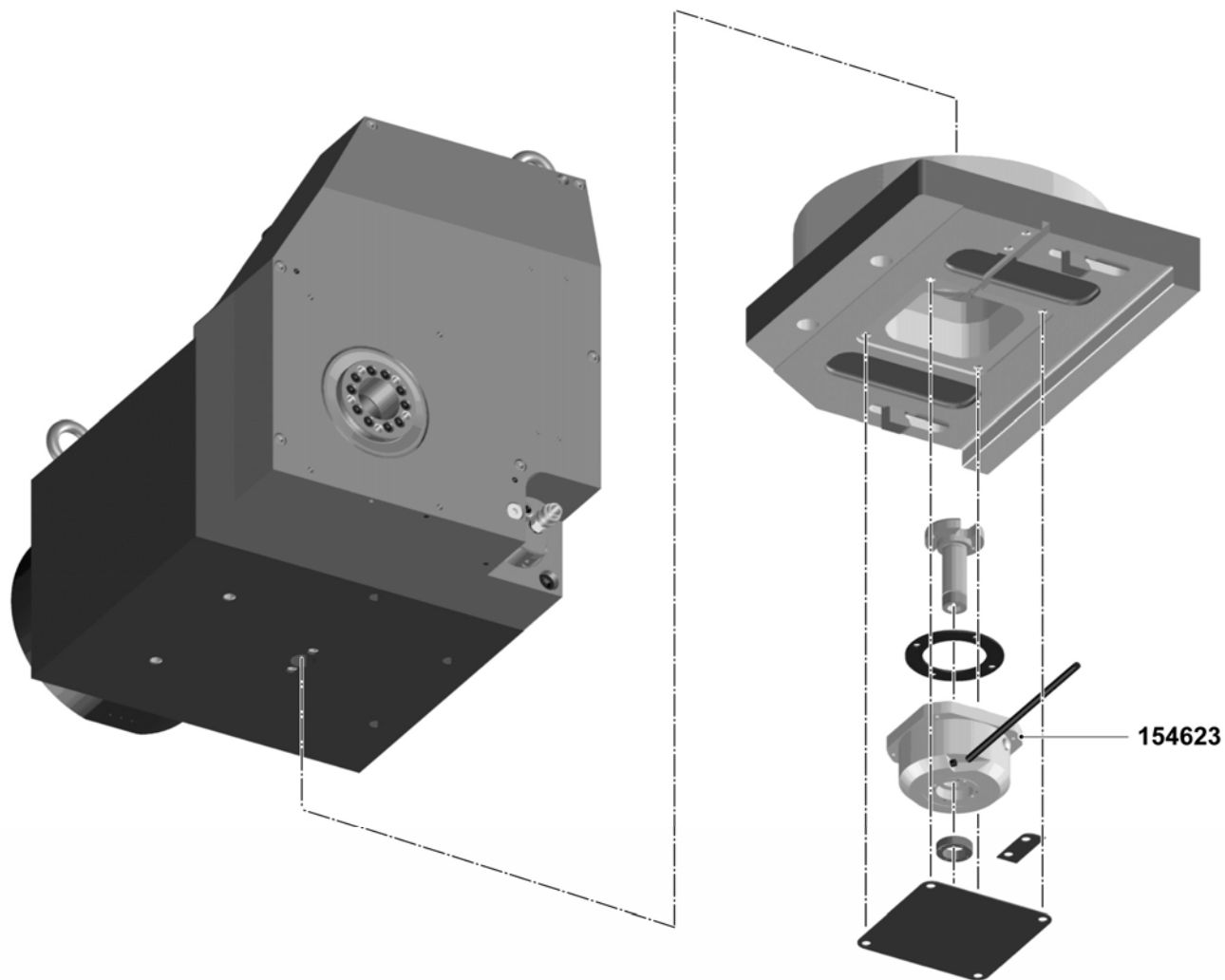

Schwenkwinkelanzeige Werkstückspindelstock / Affichage de l'angle d'orientation de la poupée porte-pièce / Swivel angle indicator for workhead

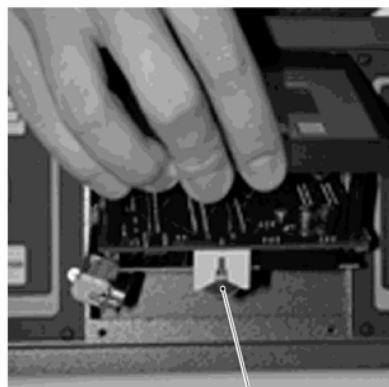

149028

Kraft-Spanneinrichtung / Vérin de serrage / Power clamping system

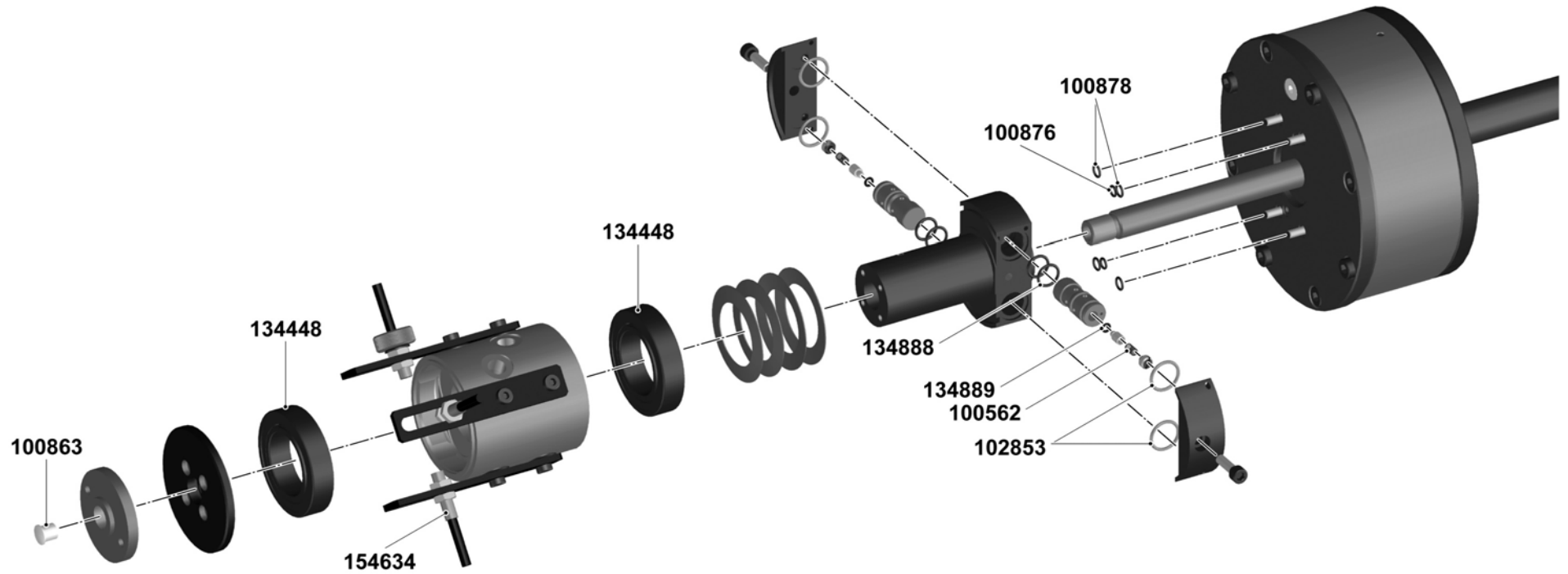

Kraft-Spanneinrichtung / Vérin de serrage / Power clamping system

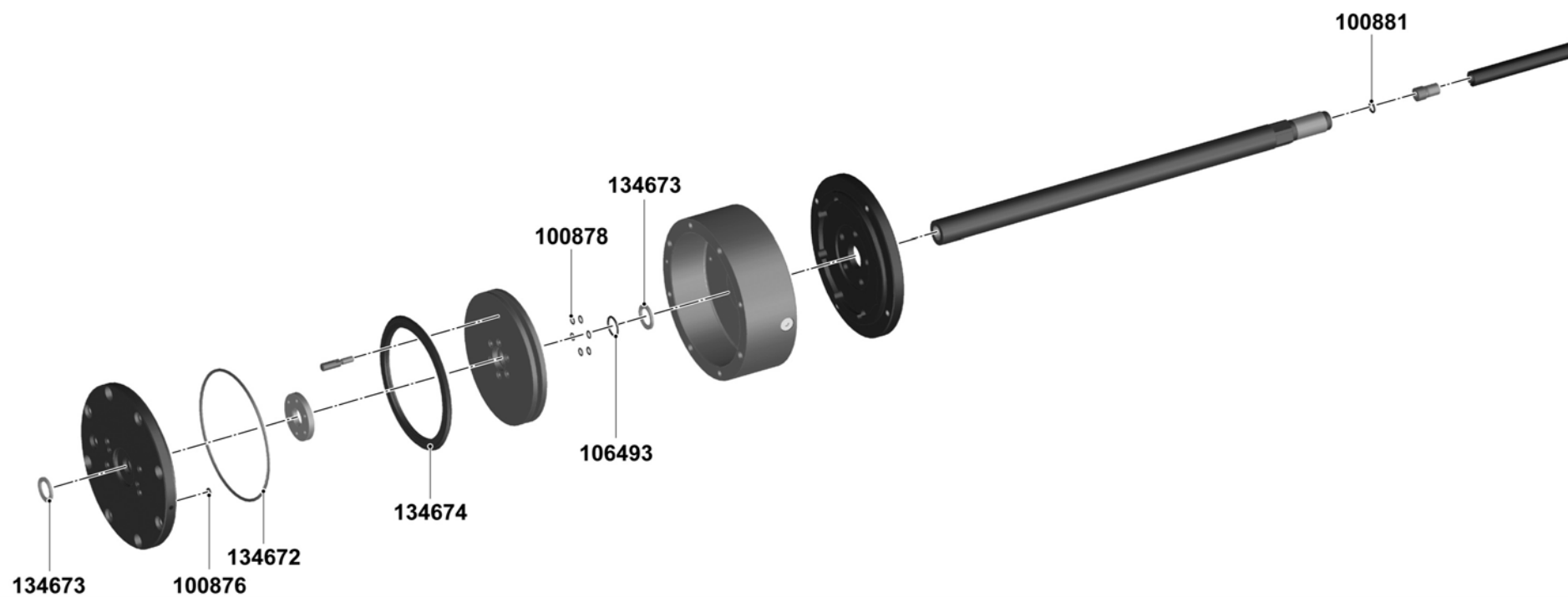

3 Hydraulikschema / Schéma hydraulique / Hydraulic diagram

Position Rep. Item	Bezeichnung	Désignation	Designation of part	Lieferant Fournisseur Supplier	Bestell-Nr. Référence Order no.	Ident.-Nr. No. d'ident. ID-no.
100.1	ÖLBEHÄLTER	RÉSERVOIR À HUILE	OIL TANK	HBE		130434
100.2	FLÜSSIGKEITSANZEIGE	VERRE REGARD DU NIVEAU D'HUILE	OIL-LEVEL INDICATOR	FLUTEC	FSA 76.1.1/12	115161
100.3	INNENZAHNRADPUMPE	POMPE A ENGRENAGES INTERIEURS	INTERNAL GEAR PUMP	JUNG	IPZ2-HR12	133148
100.4	WELLENKUPPLUNG	ACCOUPEMENT DE L'ARBRE	SHAFT COUPLING	HEB	SOFTEX 19/24	133149
100.5	DREHSTROMMOTOR	MOTEUR TRIPHASÉ	THREE-PHASE MOTOR	ETR	MBF 71 A4	153311
	N: 0,37 0,45 KW	N: 0,37 0,45 KW	N: 0,37 0,45 KW			
	N: 1500 1800 MIN ⁻¹	N: 1500 1800 MIN ⁻¹	N: 1500 1800 MIN ⁻¹			
	U: 380-420 440-480 V Y	U: 380-420 440-480 V Y	U: 380-420 440-480 V Y			
	220-240 255-280 V Δ	220-240 255-280 V Δ	220-240 255-280 V Δ			
	F: 50 60 HZ	F: 50 60 HZ	F: 50 60 HZ			
	BAUFORM B5	TYPE B5	MODEL B5			
100.6	DRUCKSCHALTER	COMMUTATEUR PRESSION	PRESSURE SWITCH	SUCO	016 409 03 1 051	153402
100.7	EINFÜLL-UND BELÜFTUNGSFILTER	FILTRE DE REMPLISSAGE ET D'AERATION	FILLING- AND VENTILATION FILTER	STAUFF	SES1-5	130475
100.8	SCHWIMMERSCHALTER	INTERRUPTEUR À FLOTTEUR	FLOAT SWITCH	KÜBLER	AFMS-L165-SB	130430
100.9	STEUERBLOCK HYDRAULIK	BLOC DE COMMANDE SYSTÈME HYDRAULIQUE	CONTROL BLOCK HYDRAULIC SYSTEM	KELLENBERGER	-	153401
100.10	FILTERELEMANT	FILTRE IMMERGÉ	FILTERELEMENT	HYDAC	0030 D 010 BN/HC	130129
100.11	DRUCKBEGRENZUNGSVENTIL	LIMITATEUR DE PRESSION	PRESSURE RELIEF VALVE	JUNG	DBV-D-G1/8"-N-NW1,5	145223
100.12	DRUCKMINDERVENTIL	MANODÉTENDEUR	PRESSURE REDUCING VALVE	JUNG	DMV-M20x1,5-NW4-80Bar	153404
100.13	STEUERBLOCK-DECKEL	COUVERCLE DU BLOC DE COMMANDE	CONTROL BLOCK CAP	KELLENBERGER	-	153419
100.14	MANOMETER 0-100 BAR	MANOMÈTRE 0-100 BAR	MANOMETER 0-100 BAR	UCC	UC-1678-100	118202
100.15	MANOMETER 0-40 BAR	MANOMÈTRE 0-40 BAR	MANOMETER 0-40 BAR	UCC	NG 63	127241
100.16	ABDECKPLATTE NG6	PLAQUE DE RECOUVREMENT NG6	COVERING PLATE NG6	MECABOR	-	132281
120.1	4/3 WEGEVENTIL	DISTRIBUTEUR 4/3 VOIES	4/3-DIRECTIONAL CONTROL VALVE	BOSCH	0 810 092 135	128443
120.3	SCHLAUCHLEITUNG DN10, L=1,5M	TUYAU FLEXIBLE DN10, L=1,5M	HOSE DN10, L=1,5M	TECALTO	2040N-06V00-DN10-1500	154009
120.5	VERSCHLUSSKUPPLUNG	ACCOUPEMENT DE FERMETURE	LOCKING COUPLING	WALTHER	SP-009-0-WR521-11-1	124116
120.5	VERSCHLUSSNIPPEL	ACCOUPEMENT DE FERMETURE	LOCKING NIPPLE	WALTHER	SP-009-2-WR017-11-1-Z02	132306
120.7	SCHLAUCHLEITUNG DN10, L=5,3M	TUYAU FLEXIBLE DN10, L=5,3M	HOSE DN10, L=5,3M	TECALTO	2040N-06V00-DN10-5300	154008
121.1	4/2 WEGEVENTIL NG6	DISTRIBUTEUR 4/3 VOIES NG6	4/3-DIRECTIONAL CONTROL VALVE NG6	BOSCH	0 810 092 109	128272
121.3	SCHLAUCHLEITUNG DN5, L=4M	TUYAU FLEXIBLE DN5, L=4M	HOSE DN5, L=4M	TECALTO	2040N-03V00-DN5-5000	154004
121.5	DROSSELRÜCKSCHLAGVENTIL	SOUPAPE D'ÉTRANGLEMENT	ONE WAY RESTRICTOR VALVE	BOSCH	1 530 147 004	129687

Position Rep. Item	Bezeichnung	Désignation	Designation of part	Lieferant Fournisseur Supplier	Bestell-Nr. Référence Order no.	Ident.-Nr. No. d'ident. ID-no.
180.0	AROBOTECHLÜNETTE	LUNETTE AROBOTECH	AROBOTECH STEADY REST	AROBOTECH		
180.1	4/2 WEGEVENTIL NG6	DISTRIBUTEUR 4/3 VOIES NG6	4/3-DIRECTIONAL CONTROL VALVE NG6	BOSCH	0 810 092 109	128272
180.2	SCHLAUCHLEITUNG DN8, L=2M	TUYAU FLEXIBLE DN8, L=2M	HOSE DN8, L=2M	TECALTO	2040N-03V00-DN8-2000	154229
180.3	DROSSELRÜCKSCHLAGVENTIL	SOUPAPE D'ÉTRANGLEMENT	ONE WAY RESTRICTOR VALVE	HYDREL	9F600S	138589
180.4	VERSCHLUSSKUPPLUNG 3/8"	ACCOUPLLEMENT DE FERMETURE 3/8"	LOCKING COUPLING 3/8"	WALTHER	LP-007-0-WR517-11-1	137799
	KUPPLUNGSNIPPEL 3/8"	NIPPLE D'ACCOUPLLEMENT 3/8"	COUPLING NIPPLE 3/8"	WALTHER	LP-007-2-WR017-11-1	137186
180.5	SCHLAUCHLEITUNG DN8, L=2M	TUYAU FLEXIBLE DN8, L=2M	HOSE DN8, L=2M	TECALTO	2040N-03V00-DN8-2000	154229
180.6	SCHLAUCHLEITUNG DN8, L=5,5M	TUYAU FLEXIBLE DN8, L=5,5M	HOSE DN8, L=5,5M	TECALTO	2040N-03V00-DN8-5500	154230
180.7	KUPPLUNGSNIPPEL 3/8"	NIPPLE D'ACCOUPLLEMENT 3/8"	COUPLING NIPPLE 3/8"	WALTHER	LP-007-2-WR517-11-1	137182
	VERSCHLUSSKUPPLUNG 3/8"	ACCOUPLLEMENT DE FERMETURE 3/8"	LOCKING COUPLING 3/8"	WALTHER	LP-007-0-WR017-11-1	137181
180.9	SCHLAUCHLEITUNG DN8, L=5,5M	TUYAU FLEXIBLE DN8, L=5,5M	HOSE DN8, L=5,5M	TECALTO	2040N-03V00-DN8-5500	154230

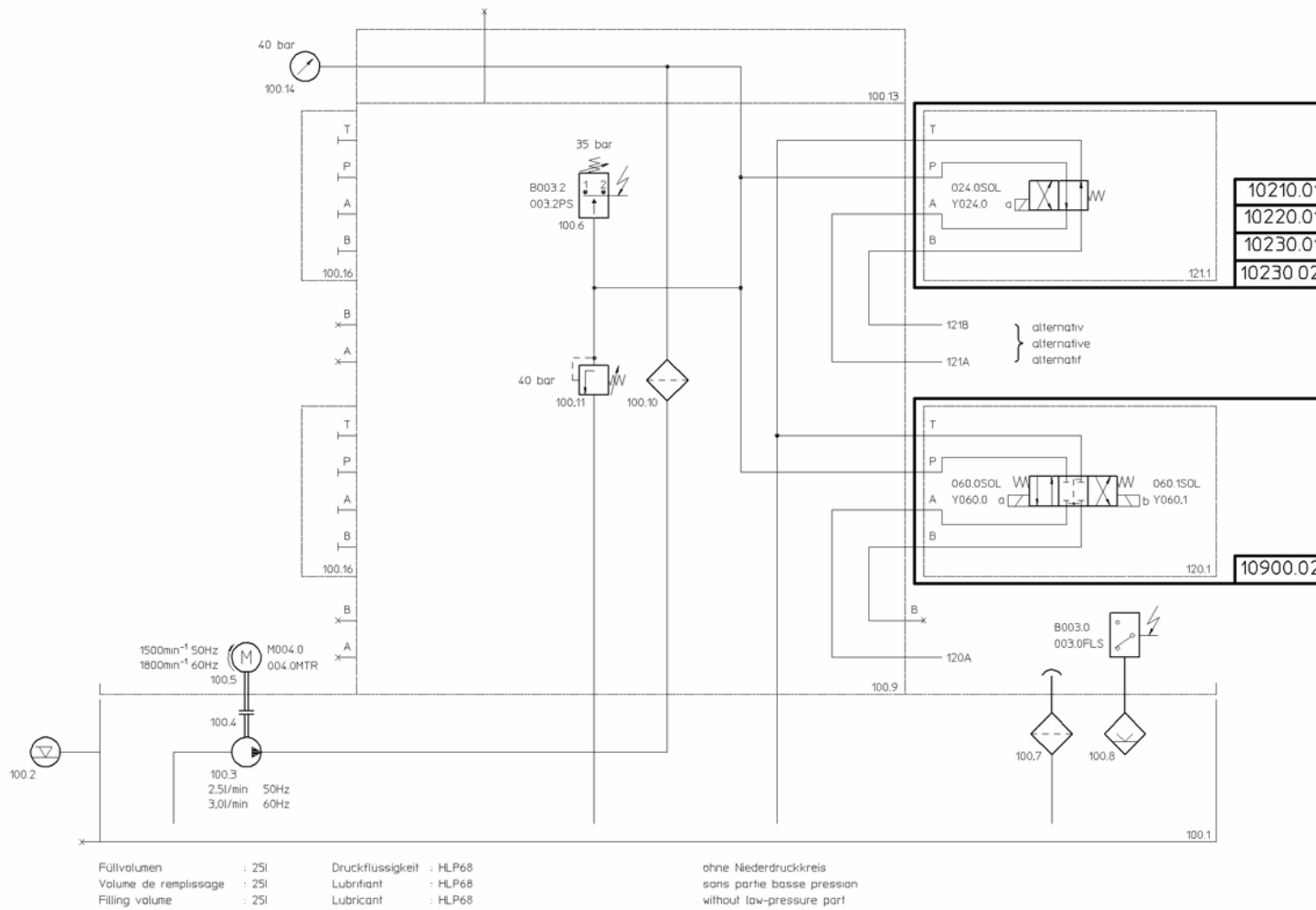

293308-1/3

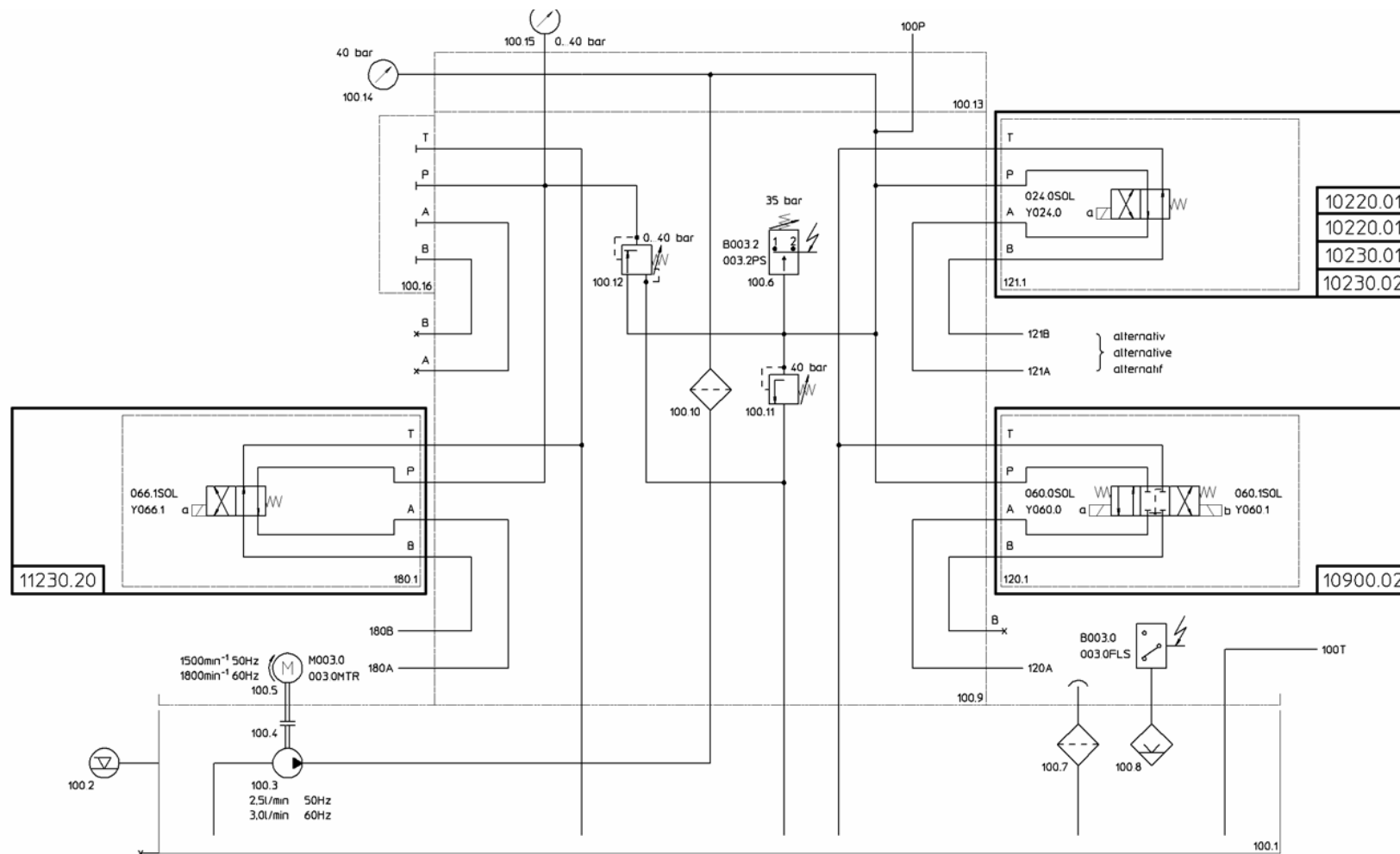

Fullvolumen : 25l Druckflüssigkeit : HLP68
 Volume de remplissage : 25l Lubrifiant : HLP68
 Filling volume : 25l Lubricant : HLP68

mit Niederdruckkreis
 avec partie basse pression
 with low-pressure part

293308-2/3

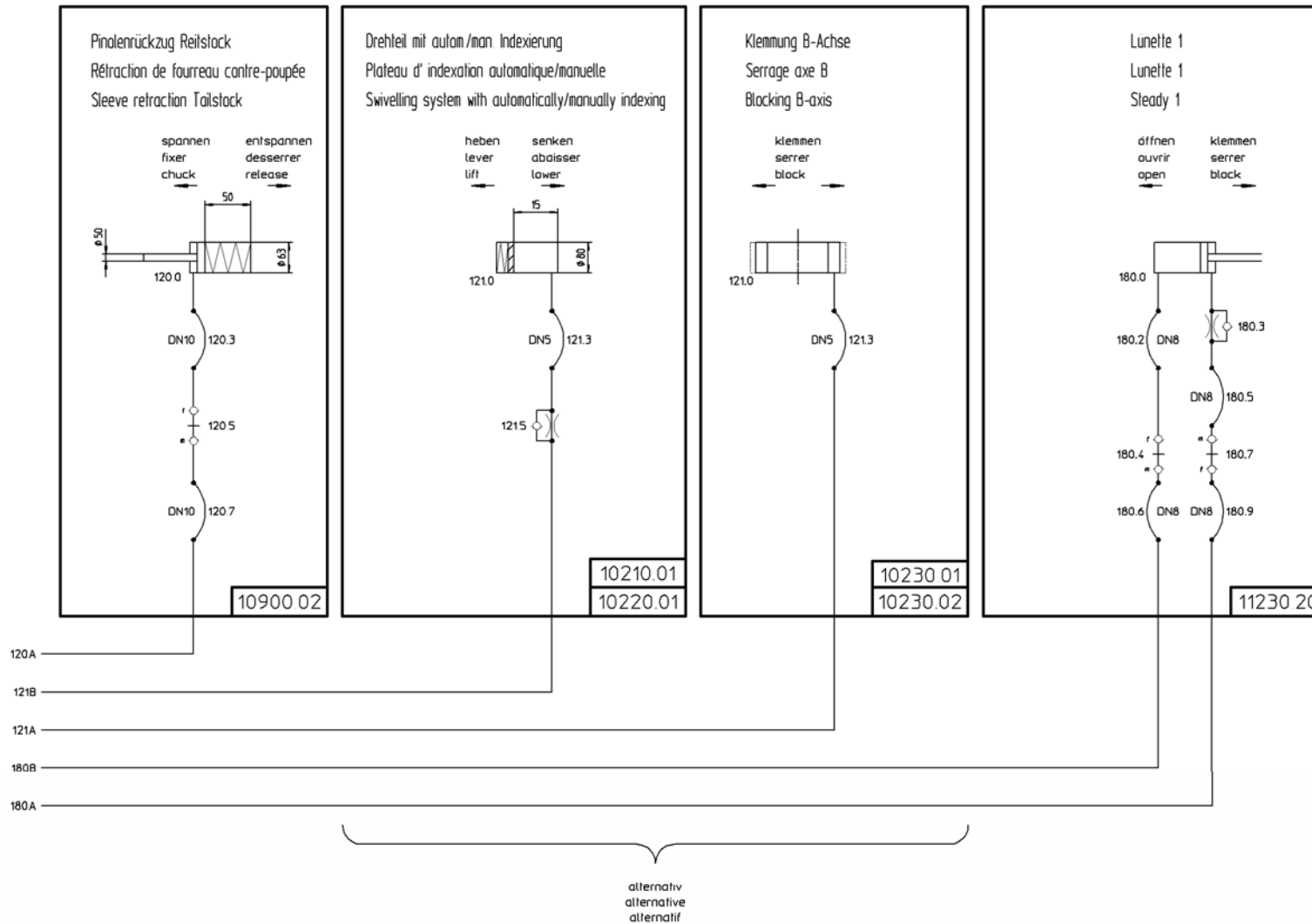

293308-3/3

4 Hydrostatik- und Schmierschema / Schéma hydrostatique et lubrification / Hydrostatic and lubrication diagram

Position Rep. Item	Bezeichnung	Désignation	Designation of part	Lieferant Fournisseur Supplier	Bestell-Nr. Référence Order no.	Ident.-Nr. No. d'ident. ID-no.
200.1	ÖLBEHÄLTER	RÉSERVOIR À HUILE	OIL TANK	HBE		130434
200.2	FLÜSSIGKEITSANZEIGE	VERRE REGARD DU NIVEAU D'HUILE	OIL-LEVEL INDICATOR	FLUTEC	FSA 76.1.1/12	115161
200.3	INNENZAHNRADPUMPE	POMPE A ENGRENAGES INTERIEURS	INTERNAL GEAR PUMP	JUNG	IPZ2-HR12	133148
200.4	WELLENKUPPLUNG	ACCOUPLLEMENT DE L'ARBRE	SHAFT COUPLING	HBE	SOFTEX 19/24	133149
200.5	DREHSTROMMOTOR	MOTEUR TRIPHASÉ	THREE-PHASE MOTOR	ETR	MBF 71 A4	130482
	N: 0,37 0,45 KW	N: 0,37 0,45 KW	N: 0,37 0,45 KW			
	N: 1500 1800 MIN ⁻¹	N: 1500 1800 MIN ⁻¹	N: 1500 1800 MIN ⁻¹			
	U: 380-420 440-480 V Y	U: 380-420 440-480 V Y	U: 380-420 440-480 V Y			
	220-240 255-280 V Δ	220-240 255-280 V Δ	220-240 255-280 V Δ			
	F: 50 60 HZ	F: 50 60 HZ	F: 50 60 HZ			
	BAUFORM B5	TYPE B5	MODEL B5			
200.6	WÄRMETAUSCHER	ECHANGEUR THERMIQUE	HEAT EXCHANGER	SWEP	B5	156203
200.7	EINFÜLL-UND BELÜFTUNGSFILTER	FILTRE DE REMPLISSAGE ET D'AÉRATION	FILLING- AND VENTILATION FILTER	STAUFF	SES1-5	130475
200.8	SCHWIMMERSCHALTER	INTERRUPTEUR À FLOTTEUR	FLOAT SWITCH	KÜBLER	AFMS-LI65-SB	130430
200.9	STEUERBLOCK HYDROSTATIK	BLOC DE COMMANDE GROUPE HYDROSTATIQUE	CONTROL BLOCK HYDROSTATIC ASSEMBLY	KELLENBERGER		153417
200.10	FILTERELEMENT	FILTRE IMMERGÉ	FILTERELEMENT	HYDAC	0030 D 010 BN/HC	130129
200.11	DRUCKBEGRENZUNGSVENTIL	LIMITATEUR DE PRESSION	PRESSURE RELIEF VALVE	WEIDMANN	DBD10-E04-F70	153403
200.12	DIFF. DRUCKANZEIGE 5 BAR	AFFICHAGE DE PRESSION 5 BAR	DIFF. PRESSURE GAUGE 5 BAR	HYDAC	VM 5 C.0	127363
200.13	STEUERBLOCK-DECKEL	COUVERCLE DU BLOC DE COMMANDE	CONTROL BLOCK CAP	KELLENBERGER		153419
200.14	MANOMETER 0-40 BAR NG 63	MANOMÈTRE 0-40 BAR NG 63	MANOMETER 0-40 BAR NG 63	UCC	UC 1676-40	127241
200.15	ABDECKPLATTE NG6	PLAQUE DE RECOUVREMENT NG6	COVERING PLATE NG6	MECABOR		132281
200.16	RÜCKSCHLAGVENTIL	CLAPET DE NON RETOUR	CHECK VALVE	TECALTO	RHV 15-PLR-ED	130041
210.1	PM-REGLER	REGULATEUR PM	PM-REGULATOR	HYPROSTATIK	08.06.005.22.8	132114
210.2	SCHLAUCHLEITUNG DN8, L=0,8M	TUYAU FLEXIBLE DN8, L=0,8M	HOSE DN8, L=0,8M	TECALTO	2040N-05V00-DN8-800	153309
210.3	SCHLAUCHLEITUNG DN12, L=1,5M	TUYAU FLEXIBLE DN12, L=1,5M	HOSE DN12, L=1,5M	TECALTO	2040N-05V00-DN12-1500	153308
210.4	VAKUUMSCHALTER SUCO 0,4 BAR	INTERRUPTEUR A VIDE SUCO 0,4 BAR	SUCO VACUUM SWITCH 0,4 BAR	BIBUS	0151 452 153 001	129072
210.5	FILTER	FILTRE	FILTER	HAWE	HF 1F	132758
210.6	SCHLAUCHLEITUNG Ø25 / L=0,6M	TUYAU FLEXIBLE Ø25 / L=0,6M	HOSE Ø25 / L=0,6M	ANGST & PFISTER	33.6103.0000	133765
211.1	PM-REGLER SPITZENWEITE 600	REGULATEUR PM DIST. ENTRE-POINTES 600	PM- REGULULATOR CENT. DIST. 600	HYPROSTATIK	08.12.002.22.8	132404
	PM-REGLER SPITZENWEITE 1000	REGULATEUR PM DIST. ENTRE-POINTES 1000	PM- REGULULATOR CENT. DIST. 1000	HYPROSTATIK	08.15.001.22.8	132158
	PM-REGLER SPITZENWEITE 1500	REGULATEUR PM DIST. ENTRE-POINTES 1500	PM- REGULULATOR CENT. DIST. 1500	HYPROSTATIK	08.18.001.22.8	132545

Position Rep. Item	Bezeichnung	Désignation	Designation of part	Lieferant Fournisseur Supplier	Bestell-Nr. Référence Order no.	Ident.-Nr. No. d'ident. ID-no.
211.2	SCHLAUCHLEITUNG DN10, L=1,6M	FLEXIBLE DN10, L=1,6M	HOSE DN10, L=1,6M	TECALTO	2010N-08V00-DN10-1570	152717
211.2	SCHLAUCHLEITUNG DN10, L=2M	FLEXIBLE DN10, L=2M	HOSE DN10, L=2M	TECALTO	2010N-08V00-DN10-2000	153299
211.3	SCHLAUCHLEITUNG DN12, L=3,8 M	FLEXIBLE DN12, L=3,8 M	HOSE DN12, L=3,8 M	TECALTO	2010N-08V00-DN12-3800	153298
211.4	VAKUUMSCHALTER SUKO 0,4 BAR	INTERRUPTEUR A VIDE SUKO 0,4 BAR	SUCO VACUUM SWITCH 0,4 BAR	BIBUS	0151 452 153 001	129072
211.5	FILTER	FILTRE	FILTER	HAWE	HF 1F	132758
211.6	DROSSELVENTIL	CLAPET ANTI-RETOUR À ÉTRANGLEMENT	FLOW CONTROL VALVE	HYDREL	9N4005	130034
211.7	SCHLAUCHLEITUNG Ø25 / L=1,26M (600)	TUYAU FLEXIBLE Ø25 / L=1,26M (600)	HOSE Ø25 / L=1,26M (600)	ANGST & PFISTER	33.6103.0000	133765
211.7	SCHLAUCHLEITUNG Ø25 / L=1,37M (1000)	TUYAU FLEXIBLE Ø25 / L=1,37M (1000)	HOSE Ø25 / L=1,37M (1000)	ANGST & PFISTER	33.6103.0000	133765
211.7	SCHLAUCHLEITUNG Ø25 / L=1,88M (1500)	TUYAU FLEXIBLE Ø25 / L=1,88M (1500)	HOSE Ø25 / L=1,88M (1500)	ANGST & PFISTER	33.6103.0000	133765
211.8	SCHLAUCHLEITUNG Ø25 / L=0,11M	TUYAU FLEXIBLE Ø25 / L=0,11M	HOSE Ø25 / L=0,11M	ANGST & PFISTER	33.6103.0000	133765
211.9	SCHLAUCHLEITUNG Ø25 / L=0,18M (600)	TUYAU FLEXIBLE Ø25 / L=0,18M (600)	HOSE Ø25 / L=0,18M (600)	ANGST & PFISTER	33.6103.0000	133765
211.9	SCHLAUCHLEITUNG Ø25 / L=0,47M (1000)	TUYAU FLEXIBLE Ø25 / L=0,47M (1000)	HOSE Ø25 / L=0,47M (1000)	ANGST & PFISTER	33.6103.0000	133765
211.9	SCHLAUCHLEITUNG Ø25 / L=0,69M (1500)	TUYAU FLEXIBLE Ø25 / L=0,69M (1500)	HOSE Ø25 / L=0,69M (1500)	ANGST & PFISTER	33.6103.0000	133765
211.10	SCHLAUCHLEITUNG Ø25 / L=0,74M (600)	TUYAU FLEXIBLE Ø25 / L=0,74M (600)	HOSE Ø25 / L=0,74M (600)	ANGST & PFISTER	33.6103.0000	133765
211.10	SCHLAUCHLEITUNG Ø25 / L=0,85M (1000)	TUYAU FLEXIBLE Ø25 / L=0,85M (1000)	HOSE Ø25 / L=0,85M (1000)	ANGST & PFISTER	33.6103.0000	133765
211.10	SCHLAUCHLEITUNG Ø25 / L=1,1M (1500)	TUYAU FLEXIBLE Ø25 / L=1,1M (1500)	HOSE Ø25 / L=1,1M (1500)	ANGST & PFISTER	33.6103.0000	133765
211.11	SCHLAUCHLEITUNG Ø25 / L=1,45M	TUYAU FLEXIBLE Ø25 / L=1,45M	HOSE Ø25 / L=1,45M	ANGST & PFISTER	33.6103.0000	133765
211.101	SCHLAUCHLEITUNG L=0,75M	TUYAU FLEXIBLE L=0,75M	HOSE L=0,75M	TECALTO	TTF 4X0,75	105360
211.102	SCHLAUCHLEITUNG L=1,03M	TUYAU FLEXIBLE L=1,03M	HOSE L=1,03M	TECALTO	TTF 4X0,75	105360
211.103	SCHLAUCHLEITUNG L=1,03M	TUYAU FLEXIBLE L=1,03M	HOSE L=1,03M	TECALTO	TTF 4X0,75	105360
211.104	SCHLAUCHLEITUNG L=0,47M	TUYAU FLEXIBLE L=0,47M	HOSE L=0,47M	TECALTO	TTF 4X0,75	105360
211.105	SCHLAUCHLEITUNG L=0,75M	TUYAU FLEXIBLE L=0,75M	HOSE L=0,75M	TECALTO	TTF 4X0,75	105360
211.106	SCHLAUCHLEITUNG L=0,75M	TUYAU FLEXIBLE L=0,75M	HOSE L=0,75M	TECALTO	TTF 4X0,75	105360
211.107	SCHLAUCHLEITUNG L=0,47M	TUYAU FLEXIBLE L=0,47M	HOSE L=0,47M	TECALTO	TTF 4X0,75	105360
211.108	SCHLAUCHLEITUNG L=0,47M	TUYAU FLEXIBLE L=0,47M	HOSE L=0,47M	TECALTO	TTF 4X0,75	105360
211.109	SCHLAUCHLEITUNG L=0,47M	TUYAU FLEXIBLE L=0,47M	HOSE L=0,47M	TECALTO	TTF 4X0,75	105360
211.110	SCHLAUCHLEITUNG L=0,75M	TUYAU FLEXIBLE L=0,75M	HOSE L=0,75M	TECALTO	TTF 4X0,75	105360
211.111	SCHLAUCHLEITUNG L=0,75M	TUYAU FLEXIBLE L=0,75M	HOSE L=0,75M	TECALTO	TTF 4X0,75	105360
211.112	SCHLAUCHLEITUNG L=0,47M	TUYAU FLEXIBLE L=0,47M	HOSE L=0,47M	TECALTO	TTF 4X0,75	105360
211.113	SCHLAUCHLEITUNG L=1,03M	TUYAU FLEXIBLE L=1,03M	HOSE L=1,03M	TECALTO	TTF 4X0,75	105360
211.114	SCHLAUCHLEITUNG L=1,03M	TUYAU FLEXIBLE L=1,03M	HOSE L=1,03M	TECALTO	TTF 4X0,75	105360
211.115	SCHLAUCHLEITUNG L=0,75M	TUYAU FLEXIBLE L=0,75M	HOSE L=0,75M	TECALTO	TTF 4X0,75	105360
211.116	SCHLAUCHLEITUNG L=1,31M	TUYAU FLEXIBLE L=1,31M	HOSE L=1,31M	TECALTO	TTF 4X0,75	105360
211.117	SCHLAUCHLEITUNG L=1,31M	TUYAU FLEXIBLE L=1,31M	HOSE L=1,31M	TECALTO	TTF 4X0,75	105360
211.118	SCHLAUCHLEITUNG L=1,03M	TUYAU FLEXIBLE L=1,03M	HOSE L=1,03M	TECALTO	TTF 4X0,75	105360

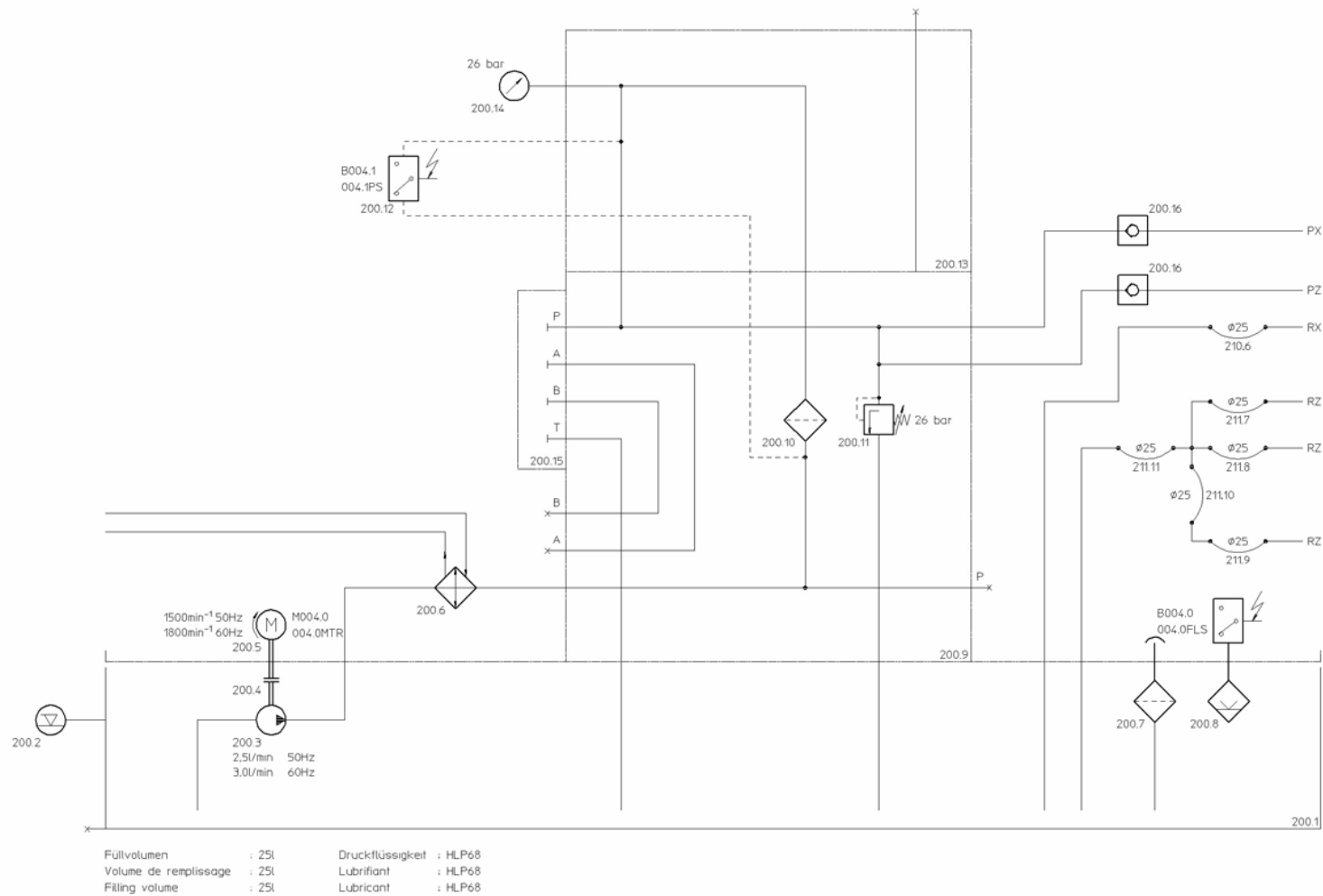

293293-1/3

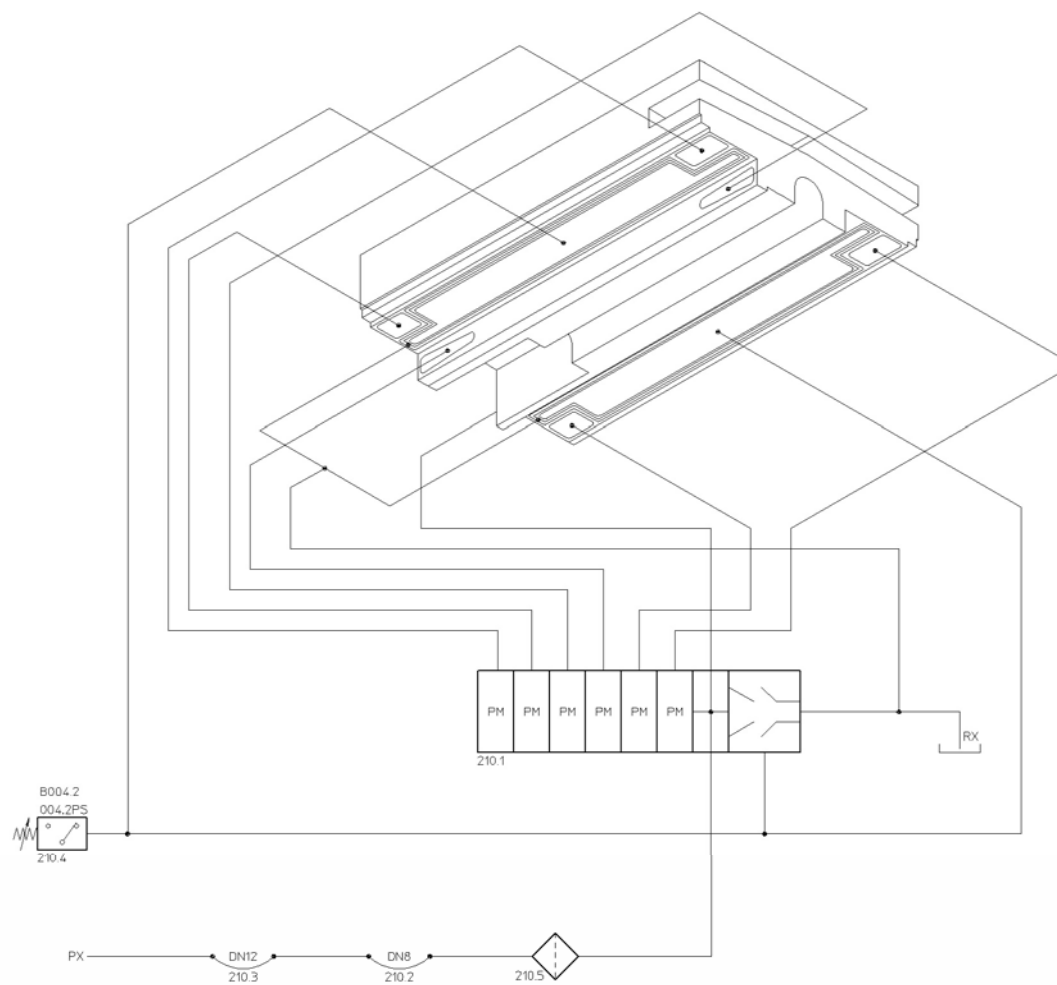

293293-2/3

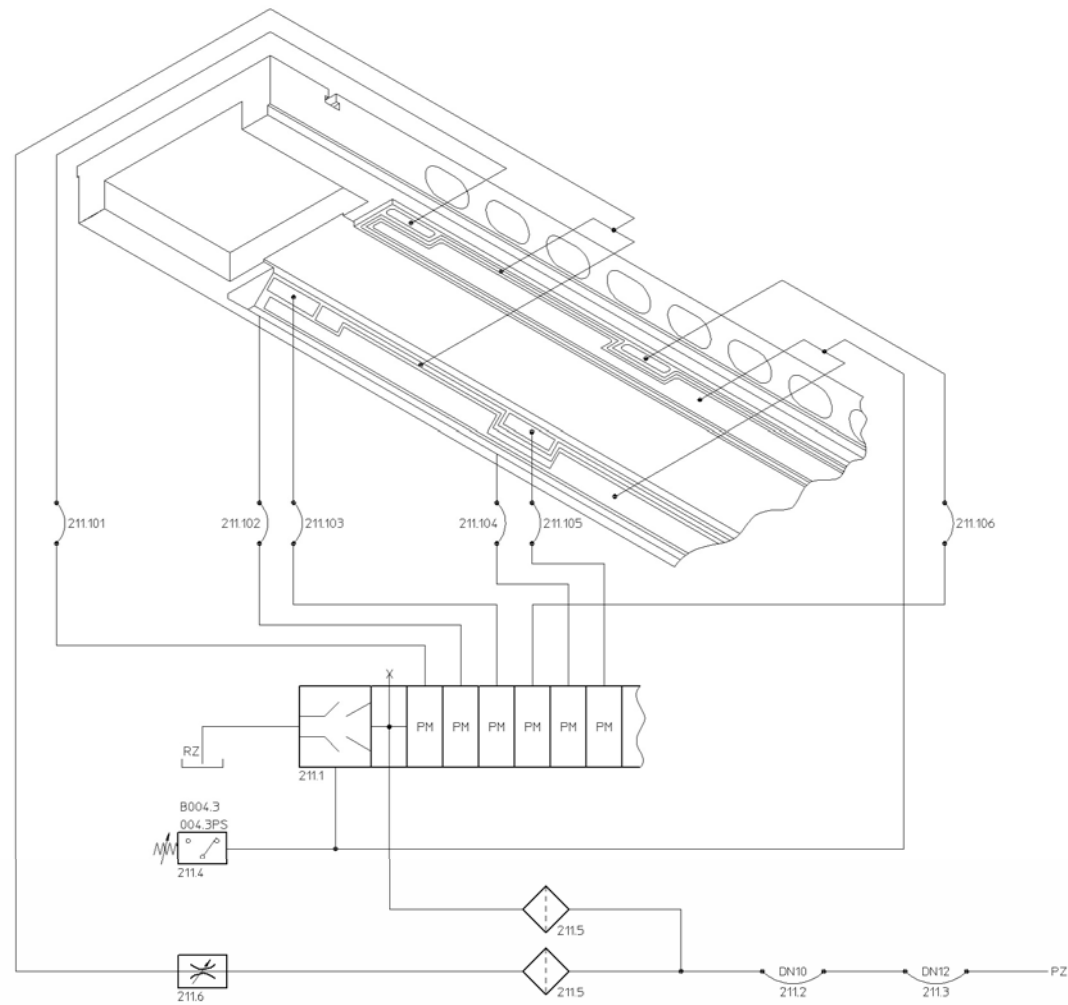

293293-3/3

5 Pneumatikschema / Schéma pneumatique / Pneumatic diagram

Position Rep. Item	Bezeichnung	Désignation	Designation of part	Lieferant Fournisseur Supplier	Bestell-Nr. Référence Order no.	Ident.-Nr. No. d'ident. ID-no.
000.1	ABSPERRVENTIL NL2	SOUPAPE D'ARRÊT NL2	SHUT-OFF VALVE NL2	BOSCH	0 821 300 922	-
000.2	SCHALLDÄMPFER	SILENCIEUX	SOUND ABSORBER	BOSCH	1 827 000 01	119500
000.3	VERTEILER 4-FACH NL2	DISTRIBUTEUR 4-VOIES NL2	4-DISTRIBUTOR NL2	BOSCH	0 821 300 920	138811
000.4	DRUCKSCHALTER	COMMUTATEUR PRESSION	PRESSURE SWITCH	SUCO	0166 405 03 1 019	145224
000.5	FILTER-DRUCKREGLER NL2	MANOSTAT FILTRE NL2	FILTER PRESSURE REGULATOR NL2	BOSCH	0 821 300 319	-
000.6	SCHLAUCHLEITUNG Ø 8/6 L = 0,2 M	TUYAU FLEXIBLE Ø 8/6 L = 0,2 M	HOSE Ø 8/6 L = 0,2 M	TRIGRESS	PUR-1198A/8X6	150709
000.7	SCHLAUCHLEITUNG Ø 8/6 L = 1,5 M	TUYAU FLEXIBLE Ø 8/6 L = 1,5 M	HOSE Ø 8/6 L = 1,5 M	TRIGRESS	PUR-1198A/8X6	150709
000.8	SCHLAUCHLEITUNG Ø 10/7 L = 2,0 M	TUYAU FLEXIBLE Ø 10/7 L = 2,0 M	HOSE Ø10/7 L = 2,0 M	TRIGRESS	PUR-1198A/10X7	150710
000.9	SCHALLDÄMPFER	SILENCIEUX	SOUND ABSORBER	BOSCH	1 827 000 01	119500
000.10	SCHALLDÄMPFER	SILENCIEUX	SOUND ABSORBER	BOSCH	1 827 000 01	119500
000.11	VENTILINSEL	BLOC DE VANNES	VALVE BLOCK	BOSCH	H E00 751 343	152590
000.20	SCHLAUCHLEITUNG Ø 8/6 L = 0,3 M	TUYAU FLEXIBLE Ø 8/6 L = 0,3 M	HOSE Ø 8/6 L = 0,3 M	TRIGRESS	PUR-1198A/8X6	150709
000.21	FILER-DRUCKREGLER NLI	MANOSTAT FILTRE NLI	FILTER PRESSURE REGULATOR NLI	BOSCH	0 821 300 758	-
000.22	SCHLAUCHLEITUNG Ø 8/6 L = 0,5 M	TUYAU FLEXIBLE Ø 8/6 L = 0,5 M	HOSE Ø 8/6 L = 0,5 M	TRIGRESS	PUR-1198A/8X6	150709
000.23	FEINFILTER NLI	FILTRE FIN NLI	FINE FILTER NLI	BOSCH	0 821 303 718	-
000.24	SCHLAUCHLEITUNG Ø 8/6 L = 7,0 M	TUYAU FLEXIBLE Ø 8/6 L = 7,0 M	HOSE Ø 8/6 L = 7,0 M	TRIGRESS	PUR-1198A/8X6	150709
000.25	KUPPLUNGSNIPPEL 1/4"	NIPPLE D'ACCOUPEMENT 1/4"	COUPLING NIPPLE 1/4"	LEGRIS	9086 21 13	151127
	SCHNELLKUPPLUNG 1/4"	ACCOUPEMENT 1/4"	QUICK CUPLING 1/4"	LEGRIS	9201 21 10	151770
000.26	DROSSELRÜCKSCHLAGVENTIL	SOUPAPE D'ÉTRANGLEMENT	ONE WAY RESTRICTOR VALVE	TRIGRESS	DRV55 2505 1/8"	133958
000.27	DROSSELRÜCKSCHLAGVERSCHRAUBUNG	SOUPAPE D'ÉTRANGLEMENT	ONE-WAY RESTRICTOR THREAD	LEGRIS	7010 06 10	145615
000.28	DROSSELRÜCKSCHLAGVERSCHRAUBUNG	SOUPAPE D'ÉTRANGLEMENT	ONE-WAY RESTRICTOR THREAD	LEGRIS	7011 06 10	145616
000.29	DROSSELRÜCKSCHLAGVERSCHRAUBUNG	SOUPAPE D'ÉTRANGLEMENT	ONE-WAY RESTRICTOR THREAD	LEGRIS	7011 06 10	145616
000.30	WERKSTÜCKSPINDELSTOCK STANDARD	POUPÉE PORTE-PIÈCE STANDARD	WORKHEAD STANDARD	KELLENBERGER	-	-
000.31	WERKSTÜCKSPINDELSTOCK UMLAUFEIND	POUPÉE PORTE-PIÈCE À BROCHE TOURNANTE	WORKHEAD WITH LIVE SPINDLE	KELLENBERGER	-	-
						-
000.40	LÜNETTE I	LUNETTE I	STEADY REST I	KELLENBERGER	-	-
000.41	HF-ABRICHTSPINDEL	SYSTÈME DE DRESSAGE HF	HF ROTARY DRESSING UNIT	KELLENBERGER	-	-
000.42	DROSSELRÜCKSCHLAGVERSCHRAUBUNG	SOUPAPE D'ÉTRANGLEMENT	ONE-WAY RESTRICTOR THREAD	LEGRIS	7011 06 10	145616
000.43	SCHLAUCHLEITUNG Ø 6/4 L = 2,0 M	TUYAU FLEXIBLE Ø 6/4 L = 2,0 M	HOSE Ø 6/4 L = 2,0 M	TRIGRESS	PUR-1198A/6X4	150708
000.44	KUPPLUNGSNIPPEL 1/8"	NIPPLE D'ACCOUPEMENT 1/8"	COUPLING NIPPLE 1/8"	LEGRIS	9086 20 10	145600
	SCHNELLKUPPLUNG 1/8"	ACCOUPEMENT 1/8"	QUICK CUPLING 1/8"	LEGRIS	9201 20 10	148129
000.45	SCHLAUCHLEITUNG Ø 8/6 L = 7,0 M	TUYAU FLEXIBLE Ø 8/6 L = 7,0 M	HOSE Ø 8/6 L = 7,0 M	TRIGRESS	PUR-1198A/8X6	150709
000.46	DROSSELRÜCKSCHLAGVENTIL	SOUPAPE D'ÉTRANGLEMENT	ONE WAY RESTRICTOR VALVE	TRIGRESS	DRV55 2505 1/8"	133958

Position Rep. Item	Bezeichnung	Désignation	Designation of part	Lieferant Fournisseur Supplier	Bestell-Nr. Référence Order no.	Ident.-Nr. No. d'ident. ID-no.
000.50	INNENSCHLEIFSPINDEL	BROCHE DE RECTIFICATION INTÉRIEURE	AIRLOCK I.D. GRINDING SPINDLE			
000.51	SCHLAUCHLEITUNG Ø 8/6 L = 0,25 M	TUYAU FLEXIBLE Ø 8/6 L = 0,25 M	HOSE Ø 8/6 L = 0,25 M	TRIGRESS	PUR-1198A/8X6	150709
000.52	SCHLAUCHLEITUNG Ø 8/6 L = 5,0 M	TUYAU FLEXIBLE Ø 8/6 L = 5,0 M	HOSE Ø 8/6 L = 5,0 M	TRIGRESS	PUR-1198A/8X6	150709
000.53	DROSSELRÜCKSCHLAGVENTIL	SOUPAPE D'ÉTRANGLEMENT	ONE WAY RESTRICTOR VALVE	TRIGRESS	DRV55 2505 1/8"	133958
000.60	SPANNZYLINDER	VÉRIN DE SERRAGE	POWER CLAMPING SYSTEM	KELLENBERGER	-	-
000.61	SCHLAUCHLEITUNG Ø 8/6 L = 0,4 M	TUYAU FLEXIBLE Ø 8/6 L = 0,4 M	HOSE Ø 8/6 L = 0,4 M	TRIGRESS	PUR-1198A/8X6	150709
000.62	SCHLAUCHLEITUNG Ø 8/6 L = 0,4 M	TUYAU FLEXIBLE Ø 8/6 L = 0,4 M	HOSE Ø 8/6 L = 0,4 M	TRIGRESS	PUR-1198A/8X6	150709
000.63	5/3-WEGEVENTIL	DISTRIBUTEUR 5/3 VOIES	5/3-DIRECTIONAL CONTROL VALVE	BOSCH	HE00751646	150874
000.64	SCHALLDÄMPFER 1/8"	SILENCIEUX 1/8"	SOUND ABSORBER 1/8"	BOSCH	1 827 000 000	118987
000.65	SCHALLDÄMPFER 1/8"	SILENCIEUX 1/8"	SOUND ABSORBER 1/8"	BOSCH	1 827 000 000	118987
000.66	SCHLAUCHLEITUNG Ø 8/6 L = 0,5 M	TUYAU FLEXIBLE Ø 8/6 L = 0,5 M	HOSE Ø 8/6 L = 0,5 M	TRIGRESS	PUR-1198A/8X6	150709
000.67	NORMAL-NEBELÖLER NL2	LUBRIFICATEUR-PULVÉRISATEUR NORMAL NL2	NORMAL OIL-MIST LUBRICATOR NL2	BOSCH	0 821 301 400	138812
000.68	VERTEILER 4-FACH NL2	DISTRIBUTEUR 4-VOIES NL2	4-DISTRIBUTOR NL2	BOSCH	0 821 300 920	138811
000.69	DRUCKSCHALTER	COMMUTEUR PRESSION	PRESSURE SWITCH	BOSCH	0 821 100 024	138850
000.70	DRUCKREGLER (MIT MANOMETER)	RÉGULATEUR DE PRESSION (AVEC MANOMÈTRE)	PRESSURE REGULATOR (WITH MANOMETER)	BOSCH	0 821 302 400	138810
000.71	SCHLAUCHLEITUNG Ø 10/7 L = 2,0 M	TUYAU FLEXIBLE Ø 10/7 L = 2,0 M	HOSE Ø 10/7 L = 2,0 M	TRIGRESS	PUR-1198A/10X7	150710
000.72	KUPPLUNGSNIPPEL 1/4"	NIPPLE D'ACCOUPEMENT 1/4"	COUPLING NIPPLE 1/4"	LEGRIS	9287 25 13	151967
	SCHNELLKUPPLUNG 1/4"	ACCOUPEMENT 1/4"	QUICK CUPLING 1/4"	LEGRIS	9214 25 13	151968
000.73	SCHLAUCHLEITUNG Ø 10/7 L = 5,5 M	TUYAU FLEXIBLE Ø 10/7 L =5,5 M	HOSE Ø 10/7 L = 5,5 M	TRIGRESS	PUR-1198A/10X7	150710
000.74	SCHLAUCHLEITUNG Ø 6/4 L = 0,3 M	TUYAU FLEXIBLE Ø 6/4 L =0,3 M	HOSE Ø 6/4 L = 0,3 M	TRIGRESS	PUR-1198A/6X4	150708
000.75	SCHLAUCHLEITUNG Ø 6/4 L = 0,12 M	TUYAU FLEXIBLE Ø 6/4 L =0,12 M	HOSE Ø 6/4 L = 0,12 M	TRIGRESS	PUR-1198A/6X4	150708
000.76	SCHLAUCHLEITUNG Ø 6/4 L = 0,12 M	TUYAU FLEXIBLE Ø 6/4 L =0,12 M	HOSE Ø 6/4 L = 0,12 M	TRIGRESS	PUR-1198A/6X4	150708
000.80	HF-ABRICHTGERÄT	DISPOSITIF À DRESSER HF	HF DRESSING DEVICE	MEISTER	-	142488
000.81	SCHLAUCHLEITUNG Ø 6/4 L = 3,0 M	TUYAU FLEXIBLE Ø 6/4 L = 3,0 M	HOSE Ø 6/4 L = 3,0 M	TRIGRESS	PUR-1198A/6X4	150708
000.82	SCHNELLKUPPLUNG 1/8"	ACCOUPEMENT 1/8"	QUICK CUPLING 1/8"	LEGRIS	9214 20 10	133597
	KUPPLUNGSNIPPEL 1/8"	NIPPLE D'ACCOUPEMENT 1/8"	COUPLING NIPPLE 1/8"	LEGRIS	9287 20 10	133596
000.83	SCHLAUCHLEITUNG Ø 6/4 L = 8,0 M	TUYAU FLEXIBLE Ø 6/4 L = 8,0 M	HOSE Ø 6/4 L = 8,0 M	TRIGRESS	PUR-1198A/6X4	150708
000.84	DROSSELRÜCKSCHLAGVERSCHRÄUBUNG	SOUPAPE D'ÉTRANGLEMENT	ONE-WAY RESTRICTOR THREAD	LEGRIS	7010 06 10	145615
000.85	MICRO-NEBELÖLER NLI	MICRO LUBRIFICATEUR- PULVÉRISATEUR NLI	MICRO OIL-MIST LUBRICATOR NLI	BOSCH	0 821 301 702	138808
000.86	SCHLAUCHLEITUNG Ø 8/6 L = 1,0 M	TUYAU FLEXIBLE Ø 8/6 L = 1,0 M	HOSE Ø 8/6 L = 1,0 M	TRIGRESS	PUR-1198A/8X6	150709
001.1	2X 3/2-WEGEVENTIL GR 02	2X DISTRIBUTEUR 3/2 VOIES	2X 3/2-DIRECTIONAL CONTROL VALVE	BOSCH	0 820 037 102	145404
001.02	WASSERVENTIL	VANNE À EAU	WATER VALVE	VEKTOR	VPST 024530	149870
001.021	SCHLAUCHLEITUNG Ø 6/4 L = 5,0 M	TUYAU FLEXIBLE Ø 6/4 L = 5,0 M	HOSE Ø 6/4 L = 5,0 M	TRIGRESS	PUR-1198A/6X4	150708

Position Rep. Item	Bezeichnung	Désignation	Designation of part	Lieferant Fournisseur Supplier	Bestell-Nr. Référence Order no.	Ident.-Nr. No. d'ident. ID-no.
001.04	WASSERVENTIL	VANNE À EAU	WATER VALVE	VEKTOR	VPST 024530	149870
001.042	SCHLAUCHLEITUNG Ø 6/4 L = 5,0 M	TUYAU FLEXIBLE Ø 6/4 L = 5,0 M	HOSE Ø 6/4 L = 5,0 M	TRIGRESS	PUR-1198A/6X4	150708
002.1	2X 3/2-WEGEVENTIL GR 02	2X DISTRIBUTEUR 3/2 VOIES	2X 3/2-DIRECTIONAL CONTROL VALVE	BOSCH	0 820 037 102	145404
002.02	WASSERVENTIL	VANNE À EAU	WATER VALVE	VEKTOR	VPST 024530	149870
002.021	SCHLAUCHLEITUNG Ø 6/4 L = 5,0 M	TUYAU FLEXIBLE Ø 6/4 L = 5,0 M	HOSE Ø 6/4 L = 5,0 M	TRIGRESS	PUR-1198A/6X4	150708
002.04	WASSERVENTIL	VANNE À EAU	WATER VALVE	VEKTOR	VPST 024530	149870
002.042	SCHLAUCHLEITUNG Ø 6/4 L = 5,0 M	TUYAU FLEXIBLE Ø 6/4 L = 5,0 M	HOSE Ø 6/4 L = 5,0 M	TRIGRESS	PUR-1198A/6X4	150708
003.0	FLACHZYLINDER	CYLINDRE PLAT	FLAT CYLINDER	FESTO	DZF-25-125-P-A	142816
003.1	5/2-WEGEVENTIL GR 02	DISTRIBUTEUR 5/2 VOIES	5/2-DIRECTIONAL CONTROL VALVE	BOSCH	0 820 038 126	145403
003.021	DROSSELRÜCKSCHLAGVERSCHRAUBUNG	SOUPAPE D'ÉTRANGLEMENT	ONE-WAY RESTRICTOR THREAD	LEGRIS	7010 06 19	145614
003.023	SCHLAUCHLEITUNG Ø 6/4 L = 5,0 M	TUYAU FLEXIBLE Ø 6/4 L = 5,0 M	HOSE Ø 6/4 L = 5,0 M	TRIGRESS	PUR-1198A/6X4	150708
003.042	DROSSELRÜCKSCHLAGVERSCHRAUBUNG	SOUPAPE D'ÉTRANGLEMENT	ONE-WAY RESTRICTOR THREAD	LEGRIS	7010 06 19	145614
003.044	SCHLAUCHLEITUNG Ø 6/4 L = 5,0 M	TUYAU FLEXIBLE Ø 6/4 L = 5,0 M	HOSE Ø 6/4 L = 5,0 M	TRIGRESS	PUR-1198A/6X4	150708
004.0	FLACHZYLINDER	CYLINDRE PLAT	FLAT CYLINDER	FESTO	DZF-25-125-P-A	142816
004.1	5/2-WEGEVENTIL GR 02	DISTRIBUTEUR 5/2 VOIES GR 02	5/2-DIRECTIONAL CONTROL VALVE GR 02	BOSCH	0 820 038 126	145403
004.021	DROSSELRÜCKSCHLAGVERSCHRAUBUNG	SOUPAPE D'ÉTRANGLEMENT	ONE-WAY RESTRICTOR THREAD	LEGRIS	7010 06 19	145614
004.023	SCHLAUCHLEITUNG Ø 6/4 L = 5,0 M	TUYAU FLEXIBLE Ø 6/4 L = 5,0 M	HOSE Ø 6/4 L = 5,0 M	TRIGRESS	PUR-1198A/6X4	150708
004.042	DROSSELRÜCKSCHLAGVERSCHRAUBUNG	SOUPAPE D'ÉTRANGLEMENT	ONE-WAY RESTRICTOR THREAD	LEGRIS	7010 06 19	145614
004.044	SCHLAUCHLEITUNG Ø 6/4 L = 5,0 M	TUYAU FLEXIBLE Ø 6/4 L = 5,0 M	HOSE Ø 6/4 L = 5,0 M	TRIGRESS	PUR-1198A/6X4	150708
005.0	FLACHZYLINDER (AUSSENSCHLEIFEN)	CYLINDRE PLAT (RECTIFICATION EXTÉRIEURE)	FLAT CYLINDER (EXTERNAL GRINDING)	FESTO	DZF-25-125-P-A	142816
	RUNDZYLINDER (INNENSCHLEIFEN)	CYLINDRE ROND (RECTIFICATION INTÉRIEURE)	ROUND CYLINDER (INTERNAL GRINDING)	BOSCH	0 832 032 2/HUB 198	
005.1	5/2-WEGEVENTIL GR 02	DISTRIBUTEUR 5/2 VOIES GR 02	5/2-DIRECTIONAL CONTROL VALVE GR 02	BOSCH	0 820 038 126	145403
005.021	DROSSELRÜCKSCHLAGVERSCHRAUBUNG	SOUPAPE D'ÉTRANGLEMENT	ONE-WAY RESTRICTOR THREAD	LEGRIS	7010 06 19	145614
005.023	SCHLAUCHLEITUNG Ø 6/4 L = 5,0 M	TUYAU FLEXIBLE Ø 6/4 L = 5,0 M	HOSE Ø 6/4 L = 5,0 M	TRIGRESS	PUR-1198A/6X4	150708
005.042	DROSSELRÜCKSCHLAGVERSCHRAUBUNG	SOUPAPE D'ÉTRANGLEMENT	ONE-WAY RESTRICTOR THREAD	LEGRIS	7010 06 19	145614
005.044	SCHLAUCHLEITUNG Ø 6/4 L = 5,0 M	TUYAU FLEXIBLE Ø 6/4 L = 5,0 M	HOSE Ø 6/4 L = 5,0 M	TRIGRESS	PUR-1198A/6X4	150708
006.0	FLACHZYLINDER (AUSSENSCHLEIFEN)	CYLINDRE PLAT (RECTIFICATION EXTÉRIEURE)	FLAT CYLINDER (EXTERNAL GRINDING)	FESTO	DZF-25-125-P-A	142816
	RUNDZYLINDER (INNENSCHLEIFEN)	CYLINDRE ROND (RECTIFICATION INTÉRIEURE)	ROUND CYLINDER (INTERNAL GRINDING)	BOSCH	0 832 032 2/HUB 198	
006.1	5/2-WEGEVENTIL GR 02	DISTRIBUTEUR 5/2 VOIES GR 02	5/2-DIRECTIONAL CONTROL VALVE GR 02	BOSCH	0 820 038 126	145403
006.021	DROSSELRÜCKSCHLAGVERSCHRAUBUNG	SOUPAPE D'ÉTRANGLEMENT	ONE-WAY RESTRICTOR THREAD	LEGRIS	7010 06 19	145614

Position Rep. Item	Bezeichnung	Désignation	Designation of part	Lieferant Fournisseur Supplier	Bestell-Nr. Référence Order no.	Ident.-Nr. No. d'ident. ID-no.
006.023	SCHLAUCHLEITUNG Ø 6/4 L = 5,0 M	TUYAU FLEXIBLE Ø 6/4 L = 5,0 M	HOSE Ø 6/4 L = 5,0 M	TRIGRESS	PUR-1198A/6X4	150708
006.042	DROSSELRÜCKSCHLAGVERSCHRAUBUNG	SOUPAPE D'ÉTRANGLEMENT	ONE-WAY RESTRICTOR THREAD	LEGRIS	7010 06 19	145614
006.044	SCHLAUCHLEITUNG Ø 6/4 L = 5,0 M	TUYAU FLEXIBLE Ø 6/4 L = 5,0 M	HOSE Ø 6/4 L = 5,0 M	TRIGRESS	PUR-1198A/6X4	150708
007.0	RUNDZYLINDER DOPPELWIRKEND	CYLINDRE ROND À DOUBLE EFFET	ROUND CYLINDER, DOUBLE-ACTING	BOSCH	D25-HUB50 ISO 6432	133954
007.1	5/2-WEGEVENTIL GR 02	DISTRIBUTEUR 5/2 VOIES GR 02	5/2-DIRECTIONAL CONTROL VALVE GR 02	BOSCH	0 820 038 126	145403
007.021	DROSSELRÜCKSCHLAGVERSCHRAUBUNG	SOUPAPE D'ÉTRANGLEMENT	ONE-WAY RESTRICTOR THREAD	LEGRIS	7010 06 10	145615
007.023	SCHLAUCHLEITUNG Ø 6/4 L = 5,0 M	TUYAU FLEXIBLE Ø 6/4 L = 5,0 M	HOSE Ø 6/4 L = 5,0 M	TRIGRESS	PUR-1198A/6X4	150708
007.042	DROSSELRÜCKSCHLAGVERSCHRAUBUNG	SOUPAPE D'ÉTRANGLEMENT	ONE-WAY RESTRICTOR THREAD	LEGRIS	7010 06 10	145615
007.044	SCHLAUCHLEITUNG Ø 6/4 L = 5,0 M	TUYAU FLEXIBLE Ø 6/4 L = 5,0 M	HOSE Ø 6/4 L = 5,0 M	TRIGRESS	PUR-1198A/6X4	150708
008.0	RÜCKZUGSVORRICHTUNG	DISPOSITIF DE RÉTRACTION	RETRACTION DEVICE	KELLENBERGER	-	-
008.1	5/2-WEGEVENTIL GR 02	DISTRIBUTEUR 5/2 VOIES GR 02	5/2-DIRECTIONAL CONTROL VALVE GR 02	BOSCH	0 820 038 126	145403
008.021	DROSSELRÜCKSCHLAGVERSCHRAUBUNG	SOUPAPE D'ÉTRANGLEMENT	ONE-WAY RESTRICTOR THREAD	LEGRIS	7010 06 10	145615
008.023	SCHLAUCHLEITUNG Ø 6/4 L = 2,0 M	TUYAU FLEXIBLE Ø 6/4 L = 2,0 M	HOSE Ø 6/4 L = 2,0 M	TRIGRESS	PUR-1198A/6X4	150708
008.025	KUPPLUNGSNIPPEL 1/8"	NIPPLE D'ACCOUPEMENT 1/8"	COUPLING NIPPLE 1/8"	LEGRIS	9086 21 10	145604
	VERSCHLUSSKUPPLUNG 1/8"	ACCOUPEMENT DE FERMETURE 1/8"	LOCKING COUPLING 1/8"	LEGRIS	9201 21 10	151770
008.027	SCHLAUCHLEITUNG Ø 6/4 L = 8,0 M	TUYAU FLEXIBLE Ø 6/4 L = 8,0 M	HOSE Ø 6/4 L = 8,0 M	TRIGRESS	PUR-1198A/6X4	150708
008.042	DROSSELRÜCKSCHLAGVERSCHRAUBUNG	SOUPAPE D'ÉTRANGLEMENT	ONE-WAY RESTRICTOR THREAD	LEGRIS	7010 06 10	145615
008.044	SCHLAUCHLEITUNG Ø 6/4 L = 2,0 M	TUYAU FLEXIBLE Ø 6/4 L = 2,0 M	HOSE Ø 6/4 L = 2,0 M	TRIGRESS	PUR-1198A/6X4	150708
008.046	KUPPLUNGSNIPPEL 1/8"	NIPPLE D'ACCOUPEMENT 1/8"	COUPLING NIPPLE 1/8"	TRIGRESS	21 SF IW 10 MXN 6	145618
	VERSCHLUSSKUPPLUNG 1/8"	ACCOUPEMENT DE FERMETURE 1/8"	LOCKING COUPLING 1/8"	TRIGRESS	21 KA AW 10 MPN 6	145617
008.048	SCHLAUCHLEITUNG Ø 6/4 L = 8,0 M	TUYAU FLEXIBLE Ø 6/4 L = 8,0 M	HOSE Ø 6/4 L = 8,0 M	TRIGRESS	PUR-1198A/6X4	150708
009.0	RÜCKZUGSVORRICHTUNG	DISPOSITIF DE REcul	RETRACTION DEVICE	KELLENBERGER	-	-
009.1	5/2-WEGEVENTIL GR 02	DISTRIBUTEUR 5/2 VOIES	5/2-DIRECTIONAL CONTROL VALVE	BOSCH	0 820 038 126	145403
009.021	DROSSELRÜCKSCHLAGVERSCHRAUBUNG	SOUPAPE D'ÉTRANGLEMENT	ONE-WAY RESTRICTOR THREAD	LEGRIS	7010 06 10	145615
009.023	SCHLAUCHLEITUNG Ø 6/4 L = 2,0 M	TUYAU FLEXIBLE Ø 6/4 L = 2,0 M	HOSE Ø 6/4 L = 2,0 M	TRIGRESS	PUR-1198A/6X4	150708
009.025	KUPPLUNGSNIPPEL 1/8"	NIPPLE D'ACCOUPEMENT 1/8"	COUPLING NIPPLE 1/8"	LEGRIS	9086 21 10	145604
	VERSCHLUSSKUPPLUNG 1/8"	ACCOUPEMENT DE FERMETURE 1/8"	LOCKING COUPLING 1/8"	LEGRIS	9201 21 10	151770
009.027	SCHLAUCHLEITUNG Ø 6/4 L = 8,0 M	TUYAU FLEXIBLE Ø 6/4 L = 8,0 M	HOSE Ø 6/4 L = 8,0 M	TRIGRESS	PUR-1198A/6X4	150708
009.042	DROSSELRÜCKSCHLAGVERSCHRAUBUNG	SOUPAPE D'ÉTRANGLEMENT	ONE-WAY RESTRICTOR THREAD	LEGRIS	7010 06 10	145615
009.044	SCHLAUCHLEITUNG Ø 6/4 L = 2,0 M	TUYAU FLEXIBLE Ø 6/4 L = 2,0 M	HOSE Ø 6/4 L = 2,0 M	TRIGRESS	PUR-1198A/6X4	150708
009.046	KUPPLUNGSNIPPEL 1/8"	NIPPLE D'ACCOUPEMENT 1/8"	COUPLING NIPPLE 1/8"	TRIGRESS	21 SF IW 10 MXN 6	145618
	VERSCHLUSSKUPPLUNG 1/8"	ACCOUPEMENT DE FERMETURE 1/8"	LOCKING COUPLING 1/8"	TRIGRESS	21 KA AW 10 MPN 6	145617
009.048	SCHLAUCHLEITUNG Ø 6/4 L = 8,0 M	TUYAU FLEXIBLE Ø 6/4 L = 8,0 M	HOSE Ø 6/4 L = 8,0 M	TRIGRESS	PUR-1198A/6X4	150708

Position Rep. Item	Bezeichnung	Désignation	Designation of part	Lieferant Fournisseur Supplier	Bestell-Nr. Référence Order no.	Ident.-Nr. No. d'ident. ID-no.
010.0	RÜCKZUGSVORRICHTUNG	DISPOSITIF DE RECU	RETRACTION DEVICE	KELLENBERGER	-	-
010.1	5/2-WEGEVENTIL GR 02	DISTRIBUTEUR 5/2 VOIES	5/2-DIRECTIONAL CONTROL VALVE	BOSCH	0 820 038 126	145403
010.021	DROSSELRÜCKSCHLAGVERSCHRÄUBUNG	SOUPAPE D'ÉTRANGLEMENT	ONE-WAY RESTRICTOR THREAD	LEGRIS	7010 06 10	145615
010.023	SCHLAUCHLEITUNG Ø 6/4 L = 2,0 M	TUYAU FLEXIBLE Ø 6/4 L = 2,0 M	HOSE Ø 6/4 L = 2,0 M	TRIGRESS	PUR-I 198A/6X4	150708
010.025	KUPPLUNGSNIPPEL 1/8"	NIPPLE D'ACCOUPEMENT 1/8"	COUPLING NIPPLE 1/8"	LEGRIS	9086 21 10	145604
	VERSCHLUSSKUPPLUNG 1/8"	ACCOUPEMENT DE FERMETURE 1/8"	LOCKING COUPLING 1/8"	LEGRIS	9201 21 10	151770
010.027	SCHLAUCHLEITUNG Ø 6/4 L = 8,0 M	TUYAU FLEXIBLE Ø 6/4 L = 8,0 M	HOSE Ø 6/4 L = 8,0 M	TRIGRESS	PUR-I 198A/6X4	150708
010.042	DROSSELRÜCKSCHLAGVERSCHRÄUBUNG	SOUPAPE D'ÉTRANGLEMENT	ONE-WAY RESTRICTOR THREAD	LEGRIS	7010 06 10	145615
010.044	SCHLAUCHLEITUNG Ø 6/4 L = 2,0 M	TUYAU FLEXIBLE Ø 6/4 L = 2,0 M	HOSE Ø 6/4 L = 2,0 M	TRIGRESS	PUR-I 198A/6X4	150708
010.046	KUPPLUNGSNIPPEL 1/8"	NIPPLE D'ACCOUPEMENT 1/8"	COUPLING NIPPLE 1/8"	TRIGRESS	21 SF IW 10 MXN 6	145618
	VERSCHLUSSKUPPLUNG 1/8"	ACCOUPEMENT DE FERMETURE 1/8"	LOCKING COUPLING 1/8"	TRIGRESS	21 KA AW 10 MPN 6	145617
010.048	SCHLAUCHLEITUNG Ø 6/4 L = 8,0 M	TUYAU FLEXIBLE Ø 6/4 L = 8,0 M	HOSE Ø 6/4 L = 8,0 M	TRIGRESS	PUR-I 198A/6X4	150708
011.1	5/3-WEGEVENTIL GR 02	DISTRIBUTEUR 5/3 VOIES	5/3-DIRECTIONAL CONTROL VALVE	BOSCH	0 820 039 116	145405
011.04	REITSTOCKZYLINDER	CYLINDRE DE CONTRE-POUPÉE	TAILSTOCK CYLINDER	KELLENBERGER	-	-
011.042	DROSSELRÜCKSCHLAGVERSCHRÄUBUNG	SOUPAPE D'ÉTRANGLEMENT	ONE-WAY RESTRICTOR THREAD	LEGRIS	7010 06 10	145615
011.044	SCHLAUCHLEITUNG Ø 6/4 L = 1,5 M	TUYAU FLEXIBLE Ø 6/4 L = 1,5 M	HOSE Ø 6/4 L = 1,5 M	TRIGRESS	PUR-I 198A/6X4	150708
011.046	VERSCHLUSSKUPPLUNG 1/4"	ACCOUPEMENT DE FERMETURE 1/4"	LOCKING COUPLING 1/4"	LEGRIS	9214 21 10	149932
	KUPPLUNGSNIPPEL 1/4"	NIPPLE D'ACCOUPEMENT 1/4"	COUPLING NIPPLE 1/4"	LEGRIS	9287 21 13	151036
011.048	SCHLAUCHLEITUNG Ø 6/4 L = 6,0 M	TUYAU FLEXIBLE Ø 6/4 L = 6,0 M	HOSE Ø 6/4 L = 6,0 M	TRIGRESS	PUR-I 198A/6X4	150708
012.1	2X 3/2-WEGEVENTIL GR 02	2X DISTRIBUTEUR 3/2 VOIES	2X 3/2-DIRECTIONAL CONTROL VALVE	BOSCH	0 820 037 102	145404
012.02	WASSERVENTIL	VANNE À EAU	WATER VALVE	VEKTOR	VPST 044505	153989
012.021	SCHLAUCHLEITUNG Ø 6/4 L = 1,5 M	FLEXIBLE Ø 6/4 L = 1,5 M	HOSE Ø 6/4 L = 1,5 M	TRIGRESS	PUR-I 198A/6X4	150708
012.04	OBERTISCH / REITSTOCK / WERKSTÜCKSPINDELSTOCK	TABLE SUPÉRIEURE / CONTRE-POUPÉE / POUPÉE PORTE-PRÉCE	UPPER TABLE / TAILSTOCK / WORKHEAD	KELLENBERGER	-	-
012.042	DROSSELRÜCKSCHLAGVERSCHRÄUBUNG	SOUPAPE D'ÉTRANGLEMENT	ONE-WAY RESTRICTOR THREAD	LEGRIS	7010 06 10	145615
012.044	MICRO-NEBELÖLER NLI	MICRO LUBRIFICATEUR-PULVÉRISATEUR NLI	MICRO OIL-MIST LUBRICATOR NLI	BOSCH	0 821 301 702	138808
012.046	SCHLAUCHLEITUNG Ø 6/4 L = 2,0 M	TUYAU FLEXIBLE Ø 6/4 L = 2,0 M	HOSE Ø 6/4 L = 2,0 M	TRIGRESS	PUR-I 198A/6X4	150708
012.048	SCHLAUCHLEITUNG Ø 6/4 L = 1,0 M	TUYAU FLEXIBLE Ø 6/4 L = 1,0 M	HOSE Ø 6/4 L = 1,0 M	TRIGRESS	PUR-I 198A/6X4	150708
012.050	SCHLAUCHLEITUNG Ø 6/4 L = 6,0 M	TUYAU FLEXIBLE Ø 6/4 L = 6,0 M	HOSE Ø 6/4 L = 6,0 M	TRIGRESS	PUR-I 198A/6X4	150708
012.052	SCHLAUCHLEITUNG Ø 6/4 L = 3,0 M	TUYAU FLEXIBLE Ø 6/4 L = 3,0 M	HOSE Ø 6/4 L = 3,0 M	TRIGRESS	PUR-I 198A/6X4	150708
012.054	SCHLAUCHLEITUNG Ø 6/4 L = 0,2 M	TUYAU FLEXIBLE Ø 6/4 L = 0,2 M	HOSE Ø 6/4 L = 0,2 M	TRIGRESS	PUR-I 198A/6X4	150708
012.056	SCHLAUCHLEITUNG Ø 6/4 L = 0,2 M	TUYAU FLEXIBLE Ø 6/4 L = 0,2 M	HOSE Ø 6/4 L = 0,2 M	TRIGRESS	PUR-I 198A/6X4	150708
012.058	SCHLAUCHLEITUNG Ø 6/4 L = 1,7 M	TUYAU FLEXIBLE Ø 6/4 L = 1,7 M	HOSE Ø 6/4 L = 1,7 M	TRIGRESS	PUR-I 198A/6X4	150708
012.060	KUPPLUNGSNIPPEL 1/8"	NIPPLE D'ACCOUPEMENT 1/8"	COUPLING NIPPLE 1/8"	LEGRIS	9287 21 10	149931

Position Rep. Item	Bezeichnung	Désignation	Designation of part	Lieferant Fournisseur Supplier	Bestell-Nr. Référence Order no.	Ident.-Nr. No. d'ident. ID-no.
	VERSCHLUSSKUPPLUNG 1/8"	ACCOUPEMENT DE FERMETURE 1/8"	LOCKING COUPLING 1/8"	LEGRIS	9214 21 10	149932
012.062	SCHLAUCHLEITUNG Ø 6/4 L = 2,0 M	TUYAU FLEXIBLE Ø 6/4 L = 2,0 M	HOSE Ø 6/4 L = 2,0 M	TRIGRESS	PUR-1198A/6X4	150708
012.064	SCHLAUCHLEITUNG Ø 8/6 L = 2,0 M	TUYAU FLEXIBLE Ø 8/6 L = 2,0 M	HOSE Ø 8/6 L = 2,0 M	TRIGRESS	PUR-1198A/8X6	150709
012.066	KUPPLUNGSNIPPEL 1/8"	NIPPLE D'ACCOUPEMENT 1/8"	COUPLING NIPPLE 1/8"	LEGRIS	9287 21 10	149931
	VERSCHLUSSKUPPLUNG 1/8"	ACCOUPEMENT DE FERMETURE 1/8"	LOCKING COUPLING 1/8"	LEGRIS	9214 21 10	149932
012.068	SCHLAUCHLEITUNG Ø 8/6 L = 6,0 M	TUYAU FLEXIBLE Ø 8/6 L = 6,0 M	HOSE Ø 8/6 L = 6,0 M	TRIGRESS	PUR-1198A/8X6	150709
013.1	2X 3/2-VEGEVENTIL GR 02	2X DISTRIBUTEUR 3/2 VOIES	2X 3/2-DIRECTIONAL CONTROL VALVE	BOSCH	0 820 037 102	145404
013.04	WASSERVENTIL	VANNE À EAU	WATER VALVE	VEKTOR	VPST 024530	154157
013.042	SCHLAUCHLEITUNG Ø 6/4 L = 1,5 M	TUYAU FLEXIBLE Ø 6/4 L = 1,5 M	HOSE Ø 6/4 L = 1,5 M	TRIGRESS	PUR-1198A/6X4	150708
014.1	ABDECKPLATTE	PLAQUE DE RECOUVREMENT	COVERING PLATE	BOSCH	1 825 503 932	145407

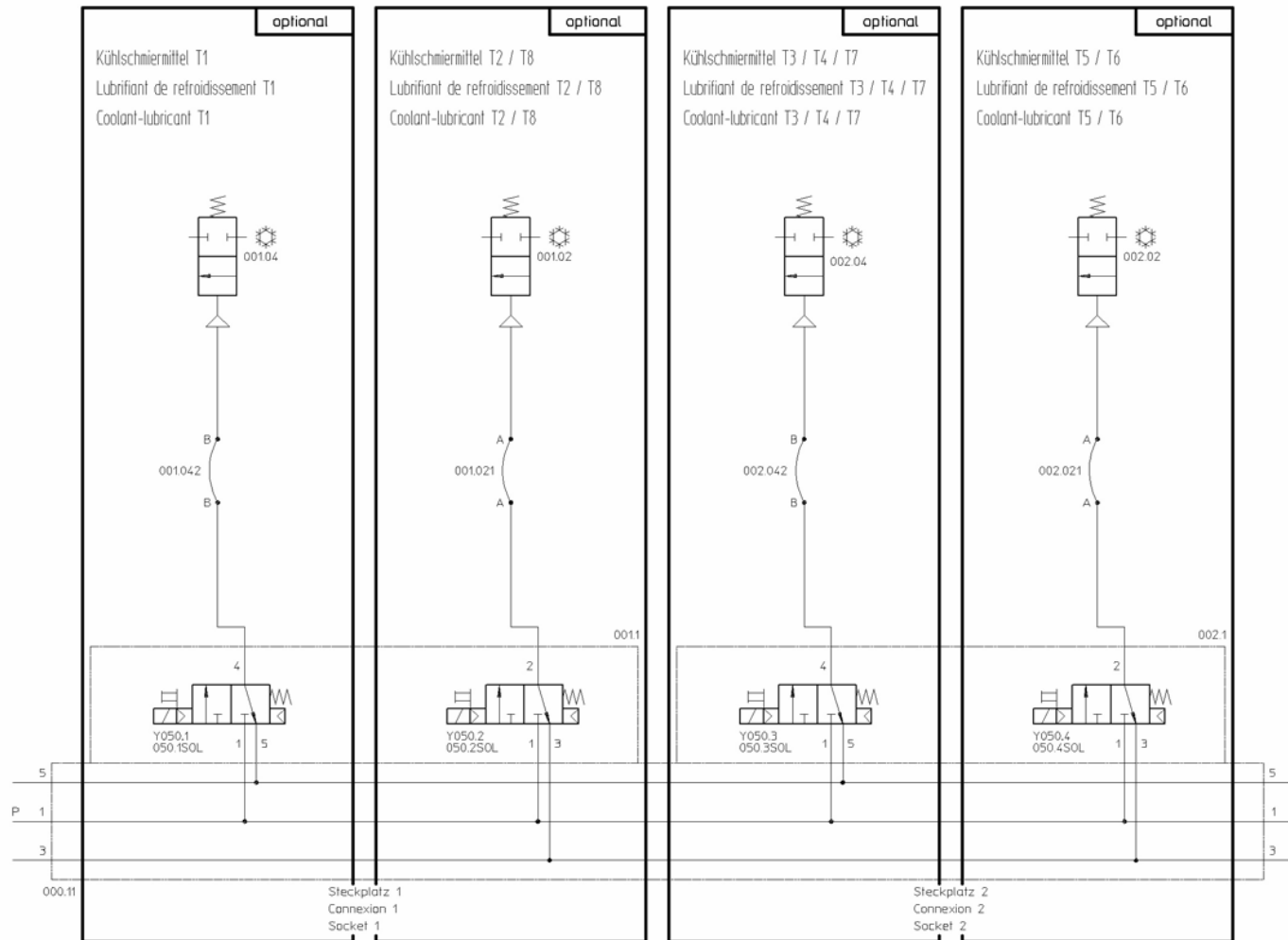

293295-1/7

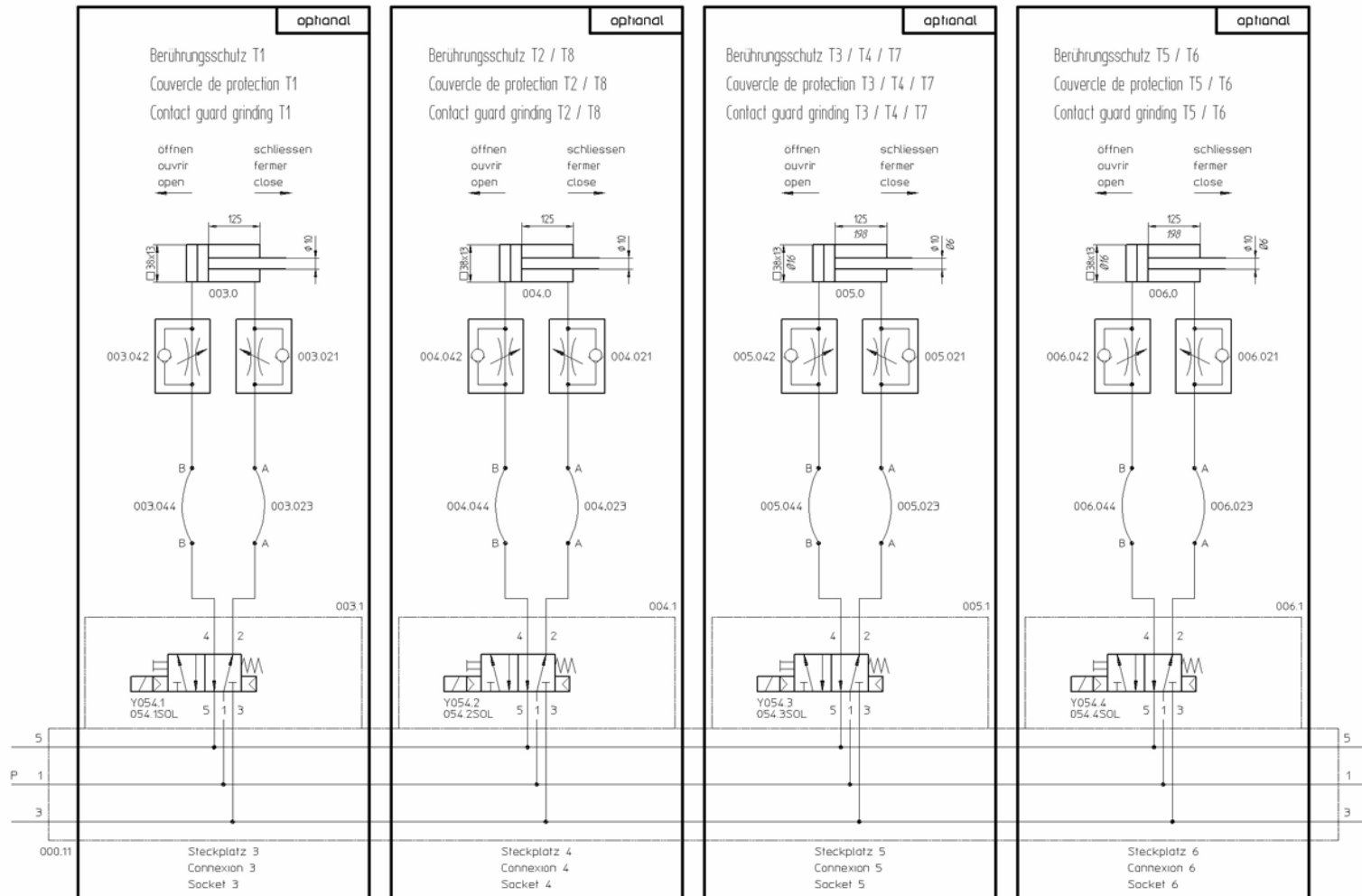

293295-2/7

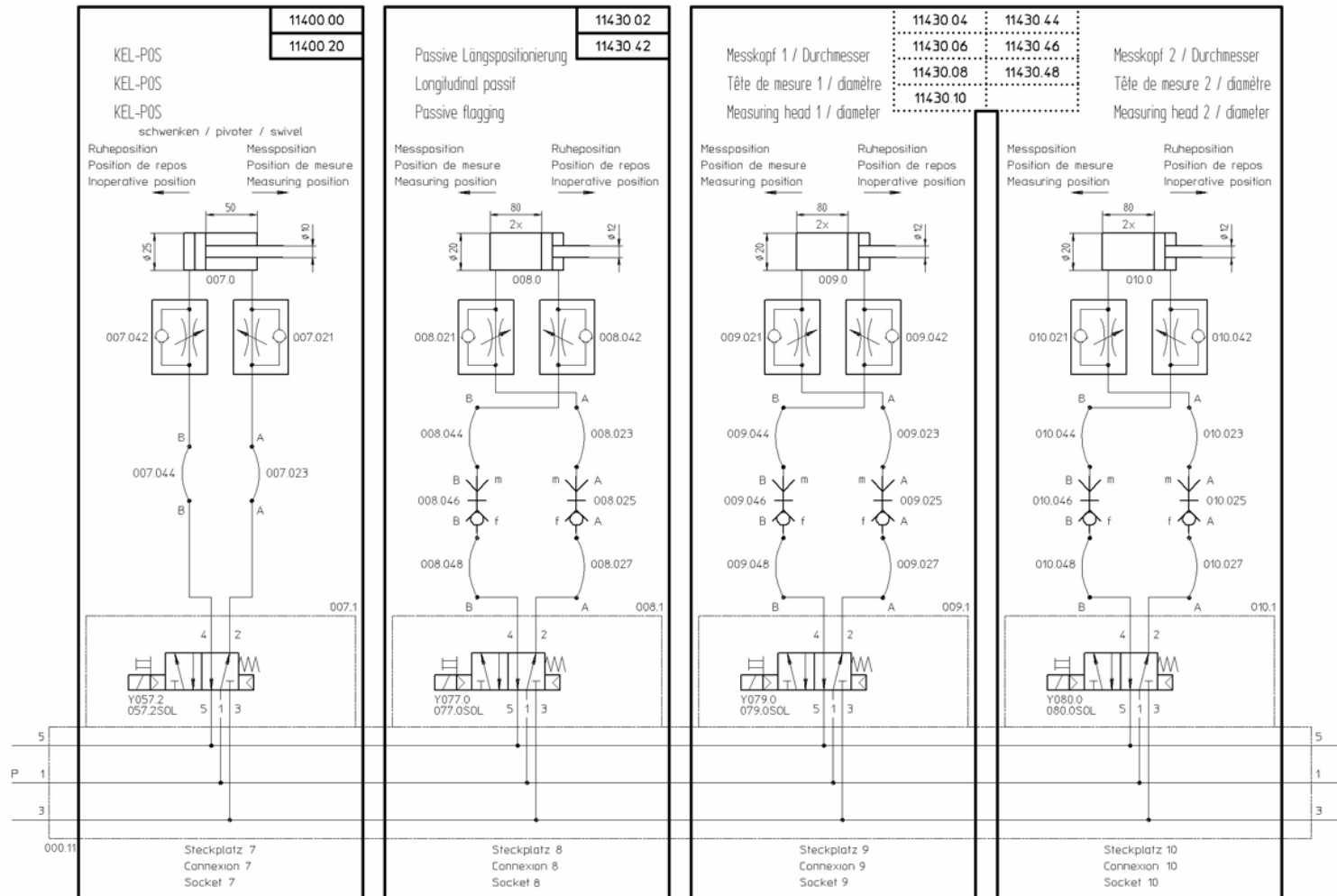

293295-3/7

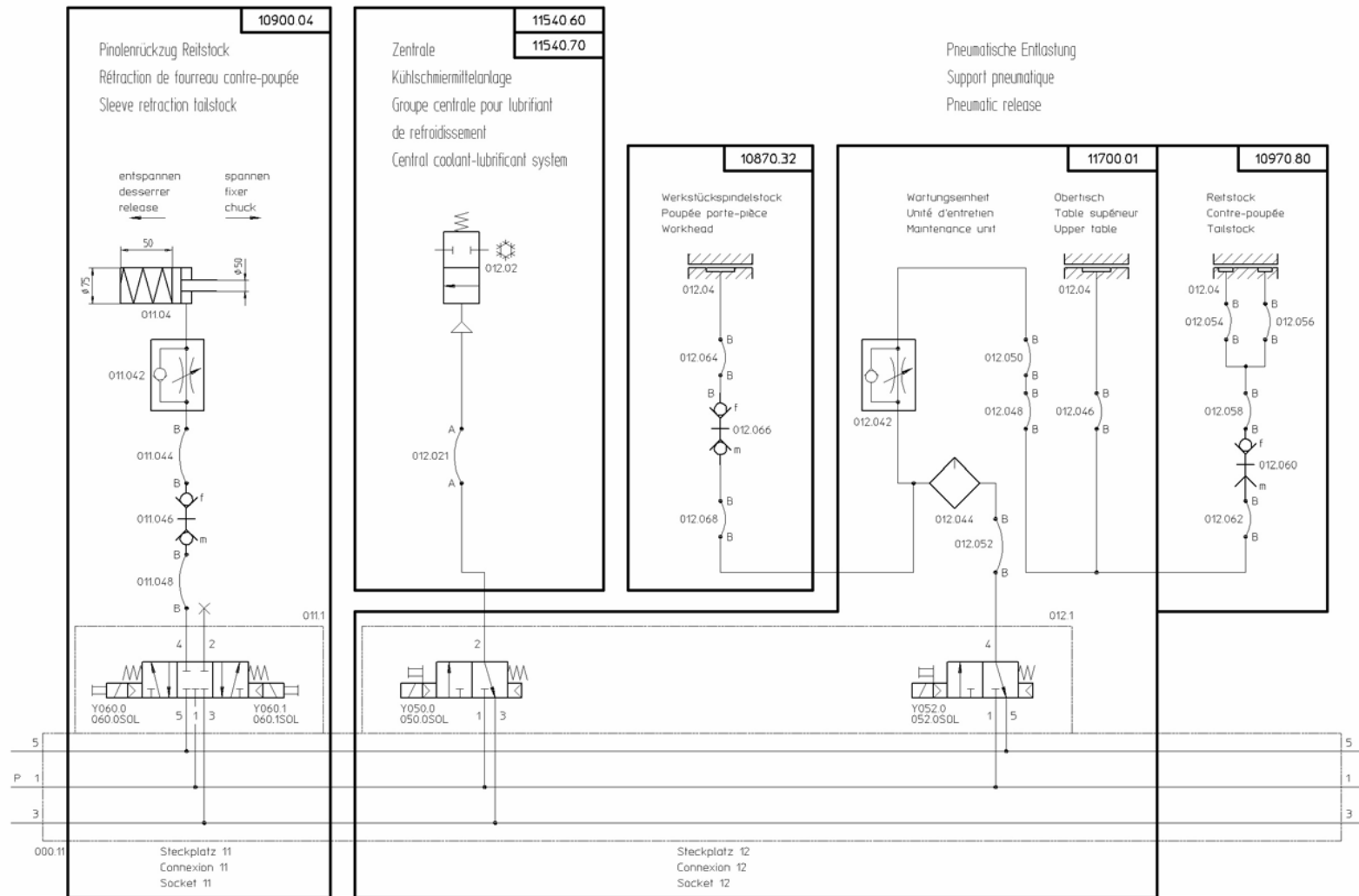

293295-4/7

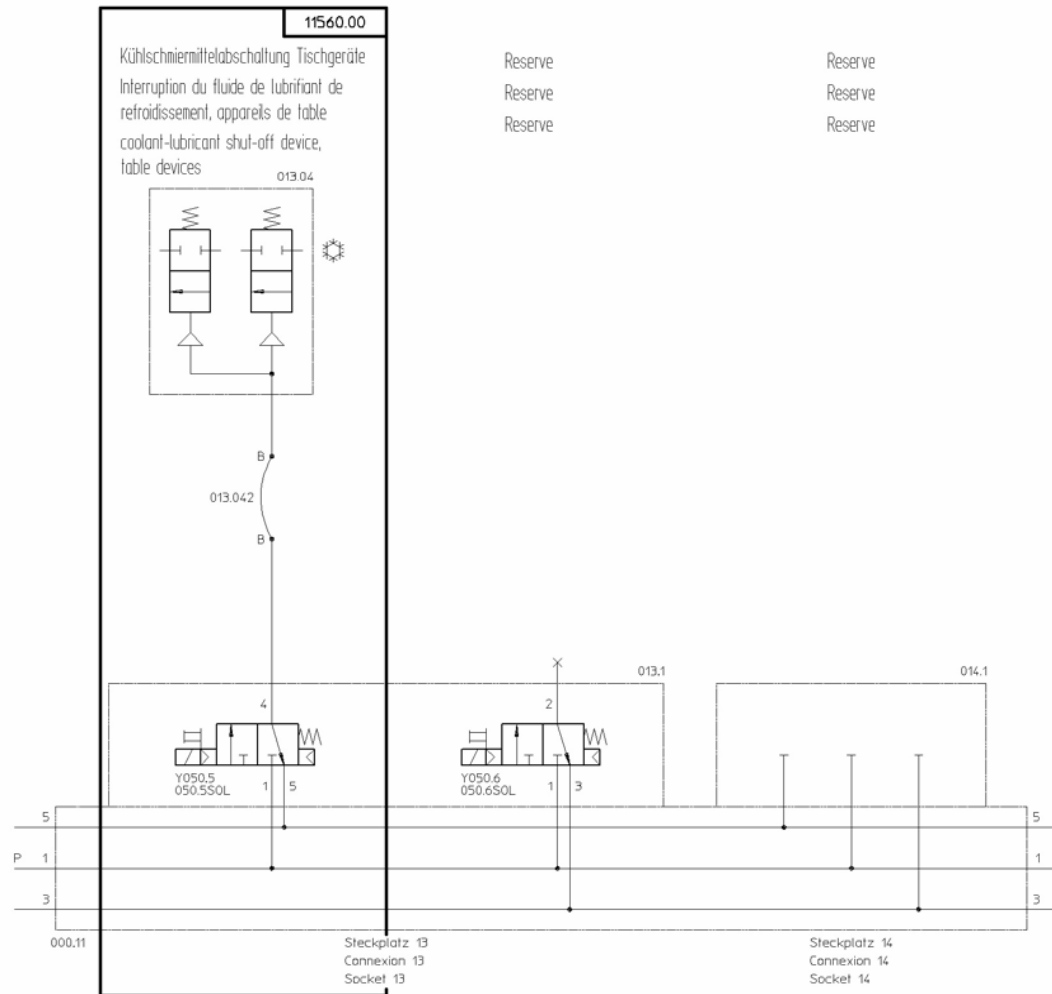

293295-5/7

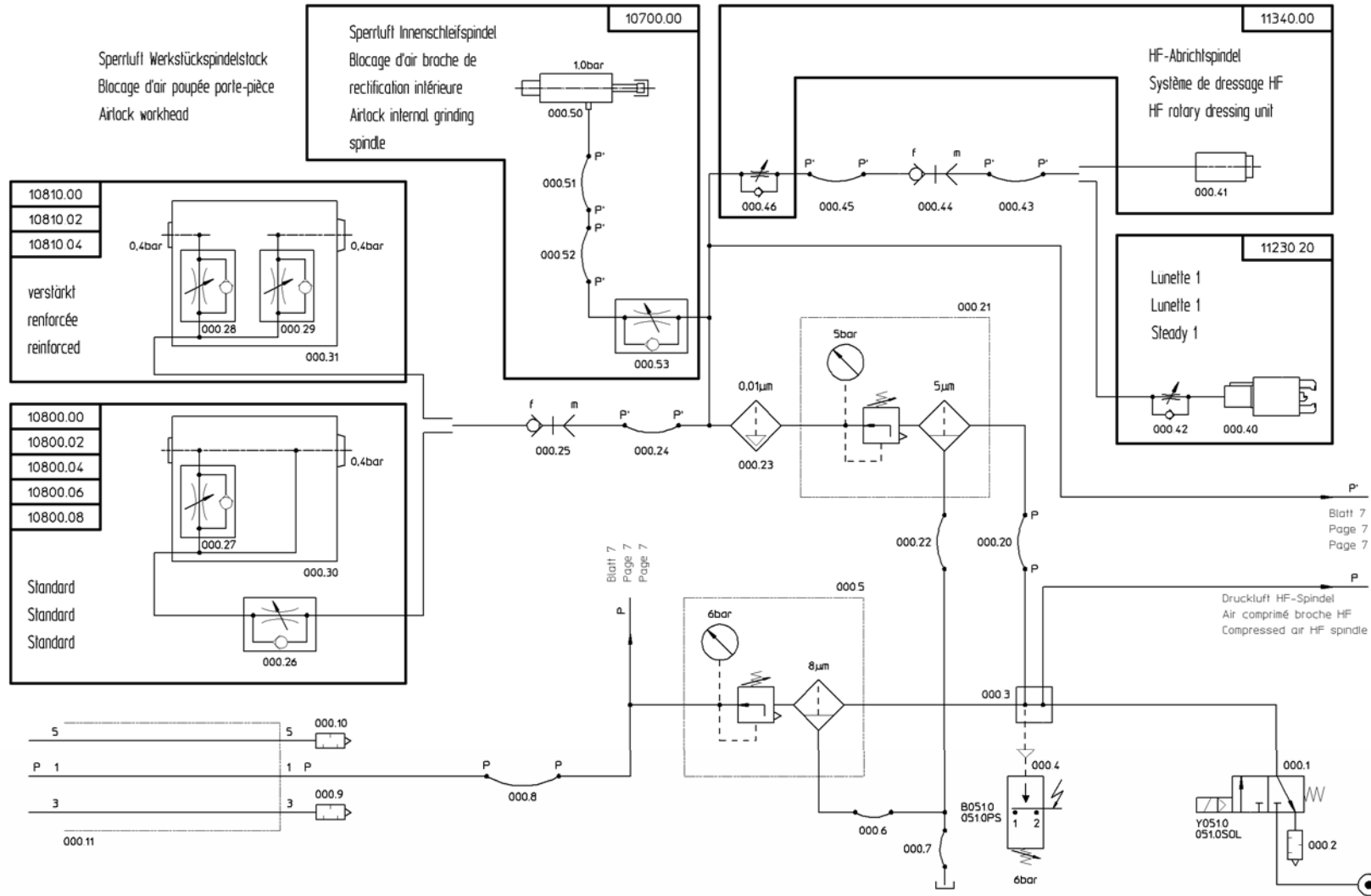

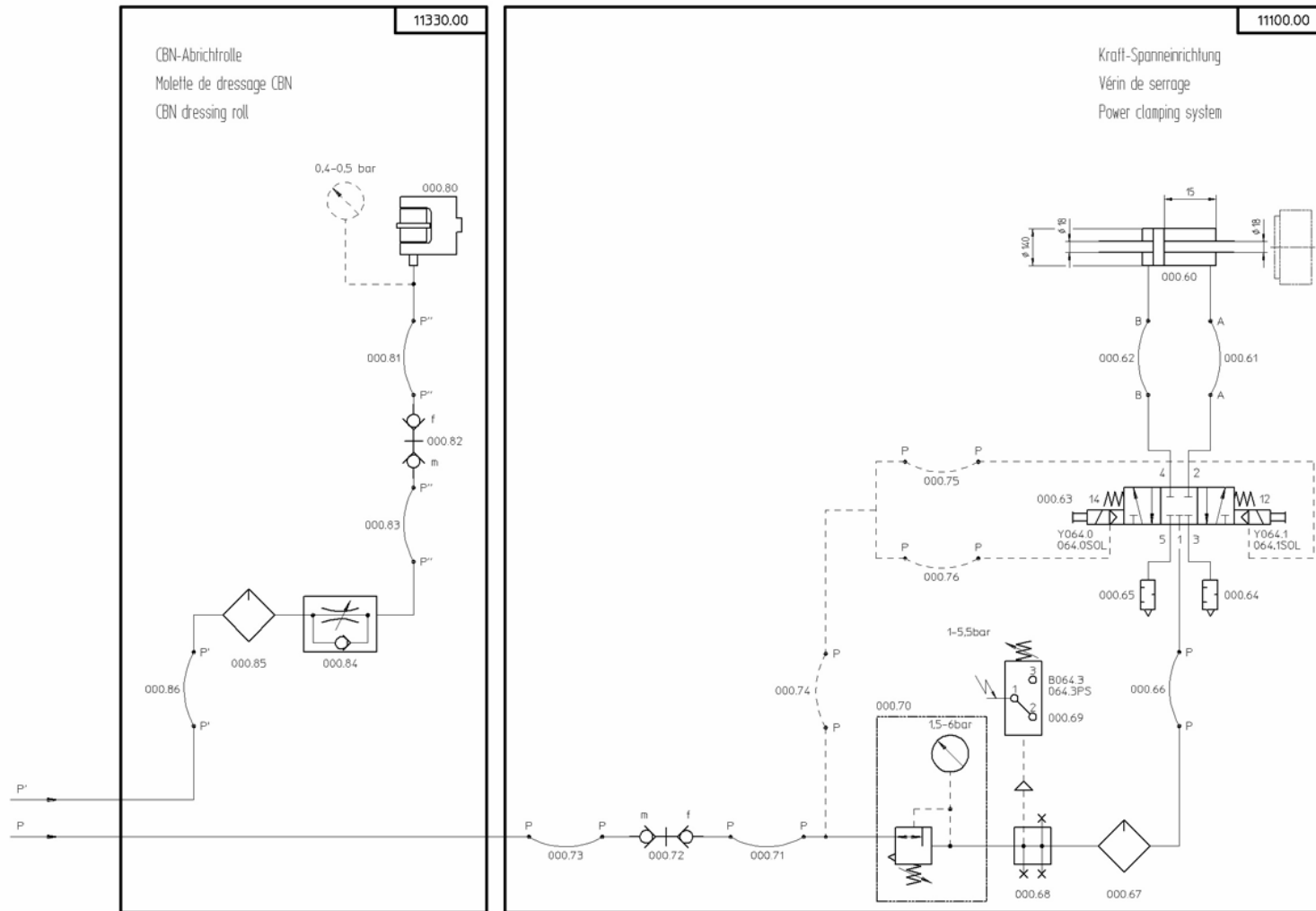

293295-717

6 Kühlschema / Schéma de refroidissement / Coolant diagram

Position Rep. Item	Bezeichnung	Désignation	Designation of part	Lieferant Fournisseur Supplier	Bestell-Nr. Référence Order no.	Ident.-Nr. No. d'ident. ID-no.
200.6	WÄRMETAUSCHER	ECHANGEUR THERMIQUE	HEAT EXCHANGER	SWEP	B5	156203
400.0	KÜHLAGGREGAT	GROUPE FRIGORIFIQUE	COOLING UNIT	BURN ENGINEERING	WK 3500-K5	154001
	KÜHLAGGREGAT	GROUPE FRIGORIFIQUE	COOLING UNIT	BURN ENGINEERING	WK 5800-K5	154002
400.1	WÄRMETAUSCHER	ECHANGEUR THERMIQUE	HEAT EXCHANGER	BURN ENGINEERING	LWS 2000-K5	153935
400.01	SCHLAUCHLEITUNG Ø 24/16 L = 2 M	TUYAU FLEXIBLE Ø 24/16 L = 2 M	HOSE Ø 24/16 L = 2 M	ANGST & PFISTER	34.61.81.0000	133764
400.02	SCHLAUCHLEITUNG Ø 24/16 L = 1 M	TUYAU FLEXIBLE Ø 24/16 L = 1 M	HOSE Ø 24/16 L = 1 M	ANGST & PFISTER	34.61.81.0000	133764
400.03	SCHLAUCHLEITUNG Ø 24/16 L = 3 M	TUYAU FLEXIBLE Ø 24/16 L = 3 M	HOSE Ø 24/16 L = 3 M	ANGST & PFISTER	34.61.81.0000	133764
400.04	SCHLAUCHLEITUNG Ø 24/16 L = 4 M	TUYAU FLEXIBLE Ø 24/16 L = 4 M	HOSE Ø 24/16 L = 4 M	ANGST & PFISTER	34.61.81.0000	133764
400.05	SCHLAUCHLEITUNG Ø 24/16 L = 2 M	TUYAU FLEXIBLE Ø 24/16 L = 2 M	HOSE Ø 24/16 L = 2 M	ANGST & PFISTER	34.61.81.0000	133764
400.06	SCHLAUCHLEITUNG Ø 24/16 L = 4 M	TUYAU FLEXIBLE Ø 24/16 L = 4 M	HOSE Ø 24/16 L = 4 M	ANGST & PFISTER	34.61.81.0000	133764
400.07	SCHLAUCHLEITUNG Ø 12/8 L = 1,2 M	TUYAU FLEXIBLE Ø 12/8 L = 1,2 M	HOSE Ø 12/8 L = 1,2 M	LEGRIS	1025U12 00 8/12	144993
400.08	SCHLAUCHLEITUNG Ø 12/8 L = 2 M	TUYAU FLEXIBLE Ø 12/8 L = 2 M	HOSE Ø 12/8 L = 2 M	LEGRIS	1025U12 00 8/12	144993
400.09	SCHLAUCHLEITUNG Ø 12/8 L = 1,2 M	TUYAU FLEXIBLE Ø 12/8 L = 1,2 M	HOSE Ø 12/8 L = 1,2 M	LEGRIS	1025U12 00 8/12	144993
400.10	DURCHFLUSSBEGRENZER 5L/MIN	LIMITEUR DU DÉBIT D'ÉCOULEMENT 5L/MIN	FLOW LIMITER 5L/MIN	NEOPERL	58.6305.1	154217

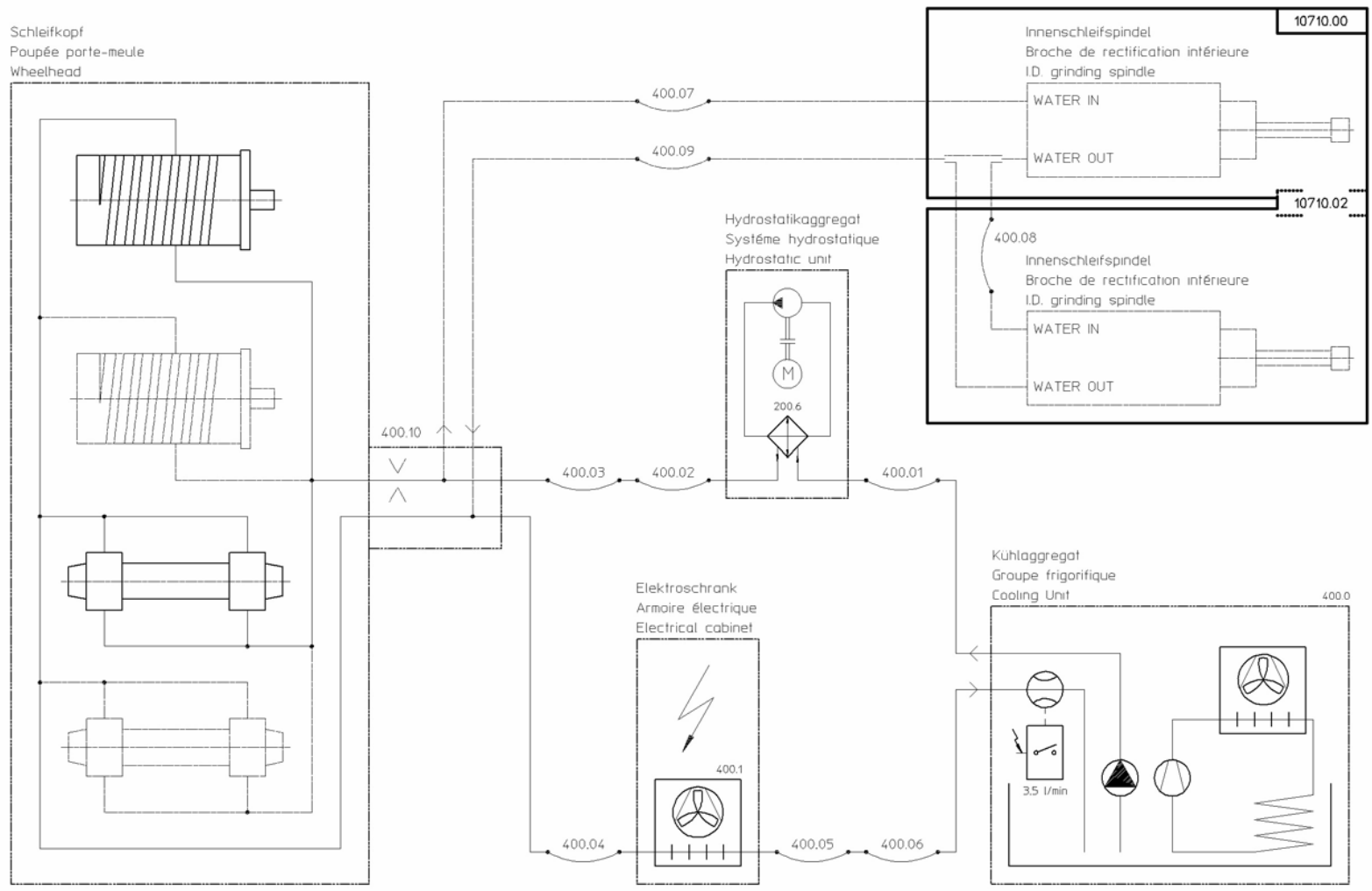

293297

7 Kühlschmiermittelschema / Schéma de lubrifiant de refroidissement / Coolant-lubricant diagram

Position Rep. Item	Bezeichnung	Désignation	Designation of part	Lieferant Fournisseur Supplier	Bestell-Nr. Référence Order no.	Ident.-Nr. No. d'ident. ID-no.
300.0	PAPIERBANDFILTER 375 I	FILTRE À RUBAN DE PAPIER 375 I	PAPERBAND FILTRATION UNIT 375 I	STREULI	SPB 4	145707
	PAPIERBANDFILTER 480 I	FILTRE À RUBAN DE PAPIER 480 I	PAPERBAND FILTRATION UNIT 480 I	STREULI	SPB 5	148188
	MAGNET-PAPIERBANDFILTER 375 I	FILTRE MAGNET. À RUBAN DE PAPIER 375 I	MAGNET PAPERBAND FILTRATION UNIT 375 I	STREULI	SAM G5-SPB4	145709
	MAGNET-PAPIERBANDFILTER 480 I	FILTRE MAGNET. À RUBAN DE PAPIER 480 I	MAGNET PAPERBAND FILTRATION UNIT 480 I	STREULI	SAM G5-SPB5	148189
	TIEFBETTFILTER 600 I	FILTRE À CUVE PROFONDE 600 I	FULL DROP FILTER 600 I	STREULI	STE-5 / 600I	143297
300.01	SCHLAUCHLEITUNG Ø 35/44 L = 2,5 M	TUYAU FLEXIBLE Ø 35/44 L = 2,5 M	HOSE Ø 35/44 L = 2,5 M	ANGST & PFISTER	33.6113.0000	133766
300.02	WASSERVENTIL	VANNE À EAU	WATER VALVE	VEKTOR	–	153989
300.03	ZWISCHENSTÜCK	RACCORD	TRANSITION PIECE	VEKTOR	–	154153
	STRÖMUNGSWÄCHTER	DISPOSITIF DE CONTRÔLE DU COURANT	FLOW MONITOR	EGE ELEKTRONIK	SC440-A2-GSP	142784
300.04	VERTEILER	DISTRIBUTEUR	DISTRIBUTOR	KELLENBERGER	–	154154
300.05	SCHLAUCHLEITUNG Ø 35/44 L = 2,55 M	TUYAU FLEXIBLE Ø 35/44 L = 2,55 M	HOSE Ø 35/44 L = 2,55 M	ANGST & PFISTER	33.6113.0000	133766
300.06	ABFLUSSROHR	TUYAU D'ÉCOULEMENT	DRAIN-PIPE	KELLENBERGER	–	132983
301.01	SCHLAUCHLEITUNG Ø 12/8 L = 0,5 m	TUYAU FLEXIBLE Ø 12/8 L = 0,5 M	HOSE Ø 12/8 L = 0,5 M	LEGRIS	1025U12 00 8/12	144993
301.02	VERTEILER RECHTS	DISTRIBUTEUR À DROITE	RIGHT DISTRIBUTOR	LEGRIS	3311 13 17 04	154558
301.03	SCHLAUCHLEITUNG Ø 12/8 L = 4,5 M	TUYAU FLEXIBLE Ø 12/8 L = 4,5 M	HOSE Ø 12/8 L = 4,5 M	LEGRIS	1025U12 00 8/12	144993
301.04	SCHLAUCHLEITUNG Ø 12/8 L = 2,0 M	TUYAU FLEXIBLE Ø 12/8 L = 2,0 M	HOSE Ø 12/8 L = 2,0 M	LEGRIS	1025U12 00 8/12	144993
301.05	SCHLAUCHLEITUNG Ø 12/8 L = 4,5 M	TUYAU FLEXIBLE Ø 12/8 L = 4,5 M	HOSE Ø 12/8 L = 4,5 M	LEGRIS	1025U12 00 8/12	144993
301.06	SCHLAUCHLEITUNG Ø 12/8 L = 0,5 M	TUYAU FLEXIBLE Ø 12/8 L = 0,5 M	HOSE Ø 12/8 L = 0,5 M	LEGRIS	1025U12 00 8/12	144993
301.07	SPÜLDÜSE	BUSE DE RINÇAGE	FLUSHING NOZZLE	KELLENBERGER	–	153865
301.11	SCHLAUCHLEITUNG Ø 12/8 L = 1,0 m	TUYAU FLEXIBLE Ø 12/8 L = 1,0 M	HOSE Ø 12/8 L = 1,0 M	LEGRIS	1025U12 00 8/12	144993
301.12	VERTEILER LINKS	DISTRIBUTEUR À GAUCHE	LEFT DISTRIBUTOR	LEGRIS	3311 13 17 04	154558
301.13	SCHLAUCHLEITUNG Ø 12/8 L = 4,5 M	TUYAU FLEXIBLE Ø 12/8 L = 4,5 M	HOSE Ø 12/8 L = 4,5 M	LEGRIS	1025U12 00 8/12	144993
301.14	SCHLAUCHLEITUNG Ø 12/8 L = 2,0 M	TUYAU FLEXIBLE Ø 12/8 L = 2,0 M	HOSE Ø 12/8 L = 2,0 M	LEGRIS	1025U12 00 8/12	144993
301.15	SCHLAUCHLEITUNG Ø 12/8 L = 4,5 M	TUYAU FLEXIBLE Ø 12/8 L = 4,5 M	HOSE Ø 12/8 L = 4,5 M	LEGRIS	1025U12 00 8/12	144993
301.16	SCHLAUCHLEITUNG Ø 12/8 L = 2,5 M	TUYAU FLEXIBLE Ø 12/8 L = 2,5 M	HOSE Ø 12/8 L = 2,5 M	LEGRIS	1025U12 00 8/12	144993
301.17	SPÜLDÜSE	BUSE DE RINÇAGE	FLUSHING NOZZLE	KELLENBERGER	–	153865
301.18	SPÜLDÜSE	BUSE DE RINÇAGE	FLUSHING NOZZLE	KELLENBERGER	–	153866
302.1	WASSERROHR 175	TUYAU D'EAU 175	WATER PIPE 175	KELLENBERGER	–	149861
302.2	WASSERROHR 225	TUYAU D'EAU 225	WATER PIPE 225	KELLENBERGER	–	149911
302.3	VERTEILER	DISTRIBUTEUR	DISTRIBUTOR	KELLENBERGER	–	149867
31x.1	WASSERVENTIL	VANNE À EAU	WATER VALVE	VEKTOR	–	149870

Position Rep. Item	Bezeichnung	Désignation	Designation of part	Lieferant Fournisseur Supplier	Bestell-Nr. Référence Order no.	Ident.-Nr. No. d'ident. ID-no.
31x.11	SCHLAUCHLEITUNG Ø 35/44 L = 1,1 M	TUYAU FLEXIBLE Ø 35/44 L = 1,1 M	HOSE Ø 35/44 L = 1,1 M	ANGST & PFISTER	33.6113.0000	133766
31x.12	SCHLAUCHLEITUNG Ø 35/44 L = 1,0 M	TUYAU FLEXIBLE Ø 35/44 L = 1,0 M	HOSE Ø 35/44 L = 1,0 M	ANGST & PFISTER	33.6113.0000	133766
31x.13	SCHLAUCHLEITUNG Ø 12/8 L = 0,3 M	TUYAU FLEXIBLE Ø 12/8 L = 0,3 M	HOSE Ø 12/8 L = 0,3 M	LEGRIS	1025U12 00 8/12	144993
31x.14	SCHLAUCHLEITUNG Ø 12/8 L = 0,9 M	TUYAU FLEXIBLE Ø 12/8 L = 0,9 M	HOSE Ø 12/8 L = 0,9 M	LEGRIS	1025U12 00 8/12	144993
31x.15	VERTEILERSTÜCK LINKS	DISTRIBUTEUR À GAUCHE	LEFT DISTRIBUTOR	KELLENBERGER	–	139445
31x.16	VERTEILERSTÜCK RECHTS	DISTRIBUTEUR À DROITE	RIGHT DISTRIBUTOR	KELLENBERGER	–	145861
31x.17	VERTEILERSTÜCK LINKS	DISTRIBUTEUR À GAUCHE	LEFT DISTRIBUTOR	KELLENBERGER	–	–
31x.18	VERTEILERSTÜCK RECHTS	DISTRIBUTEUR À DROITE	RIGHT DISTRIBUTOR	KELLENBERGER	–	–
31x.19	VERTEILERSTÜCK LINKS	DISTRIBUTEUR À GAUCHE	LEFT DISTRIBUTOR	KELLENBERGER	–	137287
31x.20	VERTEILERSTÜCK RECHTS	DISTRIBUTEUR À DROITE	RIGHT DISTRIBUTOR	KELLENBERGER	–	133622
31x.21	VERTEILERSTÜCK LINKS	DISTRIBUTEUR À GAUCHE	LEFT DISTRIBUTOR	KELLENBERGER	–	–
31x.22	VERTEILERSTÜCK RECHTS	DISTRIBUTEUR À DROITE	RIGHT DISTRIBUTOR	KELLENBERGER	–	137019
31x.23	KUGELHAHN	ROBINET À TOURNANT SPHÉRIQUE	BALL VALVE	LOC-LINE	32095	133371
31x.24	GELENKSTÜCK 6 STK.	ARTICULATION 6 PIÈCES	ARTICULATION 6 PIECES	LOC-LINE	51800	122996
31x.25	GELENKSTÜCK 2 STK.	ARTICULATION 2 PIÈCES	ARTICULATION 2 PIECES	LOC-LINE	51800	122996
31x.26	RÜCKSCHLAGVENTIL	CLAPET DE NON RETOUR	CHECK VALVE	LOC-LINE	32091	133624
31x.27	FLACHDÜSE	BUSE PLAT	FLAT NOZZLE	LOC-LINE	59867	122997
31x.28	KUGELHAHN	ROBINET À TOURNANT SPHÉRIQUE	BALL VALVE	LOC-LINE	21192	126826
31x.29	GELENKSTÜCK 30 STK.	ARTICULATION 30 PIÈCES	ARTICULATION 30 PIECES	LOC-LINE	41401	114814
31x.30	WINKELDÜSE	BUSE D'ANGLE	ANGLE NOZZLE	LOC-LINE	41471	133854
31x.31	MEHRLOCHWINKELDÜSE	BUSE D'ANGLE À PLUSIEURS TROUS	ANGLE NOZZLE MULTIHOLE	LOC-LINE	41473	133853
320.1	WASSERVENTIL	VANNE À EAU	WATER VALVE	VEKTOR	VPST 024573	154157
321.0	VERTEILER	DISTRIBUTEUR	DISTRIBUTOR	KELLENBERGER	–	153037
321.1	HAHN	ROBINET	VALVE	KELLENBERGER	–	145046
321.11	SCHLAUCHLEITUNG Ø 12/8 L = 5,0 M	TUYAU FLEXIBLE Ø 12/8 L = 5,0 M	HOSE Ø 12/8 L = 5,0 M	LEGRIS	1025U12 00 12X8	144993
321.12	VERSCHLUSSKUPPLUNG R1/4"	ACCOUPLLEMENT DE FERMETURE R1/4"	COUPLING R1/4"	LEGRIS	9201 25 13	151771
	KUPPLUNGSNIPPEL G1/4"	NIPPLE D'ACCOUPLLEMENT G1/4"	COUPLING NIPPLE G1/4"	LEGRIS	9086 25 13	145619
321.13	KUPPLUNGSNIPPEL G1/8"	NIPPLE D'ACCOUPLLEMENT G1/8"	COUPLING NIPPLE G1/8"	LEGRIS	9287 21 10	149931
	SCHNELLKUPPLING G1/8"	ACCOUPLLEMENT G1/8"	QUICK CUPLING G1/8"	LEGRIS	9214 21 10	149932
321.14	SCHLAUCHLEITUNG Ø 10/7 L = 1,5 M	TUYAU FLEXIBLE Ø 10/7 L = 1,5 M	HOSE Ø 10/7 L = 1,5 M	LEGRIS	1025U10 00 7/10	145764
321.15	SCHLAUCHLEITUNG Ø 8/5,5 L = 2,0 M	TUYAU FLEXIBLE Ø 8/5,5 L = 2,0 M	HOSE Ø 8/5,5 L = 2,0 M	LEGRIS	1025U08 00 5.5/8	121638
321.16	SCHLAUCHLEITUNG Ø 8/5,5 L = 4,5 M	TUYAU FLEXIBLE Ø 8/5,5 L = 4,5 M	HOSE Ø 8/5,5 L = 4,5 M	LEGRIS	1025U08 00 5.5/8	121638
321.17	SCHLAUCHLEITUNG Ø 8/5,5 L = 4,5 M	TUYAU FLEXIBLE Ø 8/5,5 L = 4,5 M	HOSE Ø 8/5,5 L = 4,5 M	LEGRIS	1025U08 00 5.5/8	121638
321.18	HAHN	ROBINET	VALVE	KELLENBERGER	–	145046

Position Rep. Item	Bezeichnung	Désignation	Designation of part	Lieferant Fournisseur Supplier	Bestell-Nr. Référence Order no.	Ident.-Nr. No. d'ident. ID-no.
322.1	HAHN	ROBINET	VALVE	KELLENBERGER	-	145046
322.11	SCHLAUCHLEITUNG Ø 12/8 L = 5,0 M	TUYAU FLEXIBLE Ø 12/8 L = 5,0 M	HOSE Ø 12/8 L = 5,0 M	LEGRIS	1025U12 00 12X8	144993
322.12	KUPPLUNGSNIPPEL G1/8"	NIPPLE D'ACCOUPEMENT G1/8"	COUPLING NIPPLE G1/8"	LEGRIS	9287 21 10	149931
	SCHNELLKUPPLING G1/8"	ACCOUPEMENT G1/8"	QUICK CUPLING G1/8"	LEGRIS	9214 21 10	149932
322.13	SCHLAUCHLEITUNG Ø 8/5,5 L = 2,0 M	TUYAU FLEXIBLE Ø 8/5,5 L = 2,0 M	HOSE Ø 8/5,5 L = 2,0 M	LEGRIS	1025U08 00 5.5/8	121638
322.14	SCHLAUCHLEITUNG Ø 8/5,5 L = 2,0 M	TUYAU FLEXIBLE Ø 8/5,5 L = 2,0 M	HOSE Ø 8/5,5 L = 2,0 M	LEGRIS	1025U08 00 5.5/8	121638
322.15	SCHLAUCHLEITUNG Ø 8/5,5 L = 2,0 M	TUYAU FLEXIBLE Ø 8/5,5 L = 2,0 M	HOSE Ø 8/5,5 L = 2,0 M	LEGRIS	1025U08 00 5.5/8	121638
322.16	VERTEILER	DISTRIBUTEUR	DISTRIBUTOR	KELLENBERGER	-	132382
322.17	SCHLAUCHLEITUNG Ø 6/4 L = 0,1 M	TUYAU FLEXIBLE Ø 6/4 L = 0,1 M	HOSE Ø 6/4 L = 0,1 M	JOHANNSEN	4/6 DEKABON - 1300	132383
323.11	SCHLAUCHLEITUNG Ø 12/8 L = 5,0 M	TUYAU FLEXIBLE Ø 12/8 L = 5,0 M	HOSE Ø 12/8 L = 5,0 M	LEGRIS	1025U12 00 12X8	144993
323.12	VERSCHLUSSKUPPLUNG R1/4"	ACCOUPEMENT DE FERMETURE R1/4"	COUPLING R1/4"	LEGRIS	9201 25 13	151771
	KUPPLUNGSNIPPEL G1/4"	NIPPLE D'ACCOUPEMENT G1/4"	COUPLING NIPPLE G1/4"	LEGRIS	9086 25 13	145619
323.13	SCHLAUCHLEITUNG Ø 10/7 L = 1,5 M	TUYAU FLEXIBLE Ø 10/7 L = 1,5 M	HOSE Ø 10/7 L = 1,5 M	LEGRIS	1025U10 00 10X7	145764
323.14	KUGELHAHN G1/4"	ROBINET À TOURNANT SPHÉRIQUE G1/4"	BALL VALVE G1/4"	TRIGRESS	-	060885
323.15	DREHDURCHFÜHRUNG	PASSAGE TOURNANT	ROTARY TRANSMISSION	KELLENBERGER	-	145040

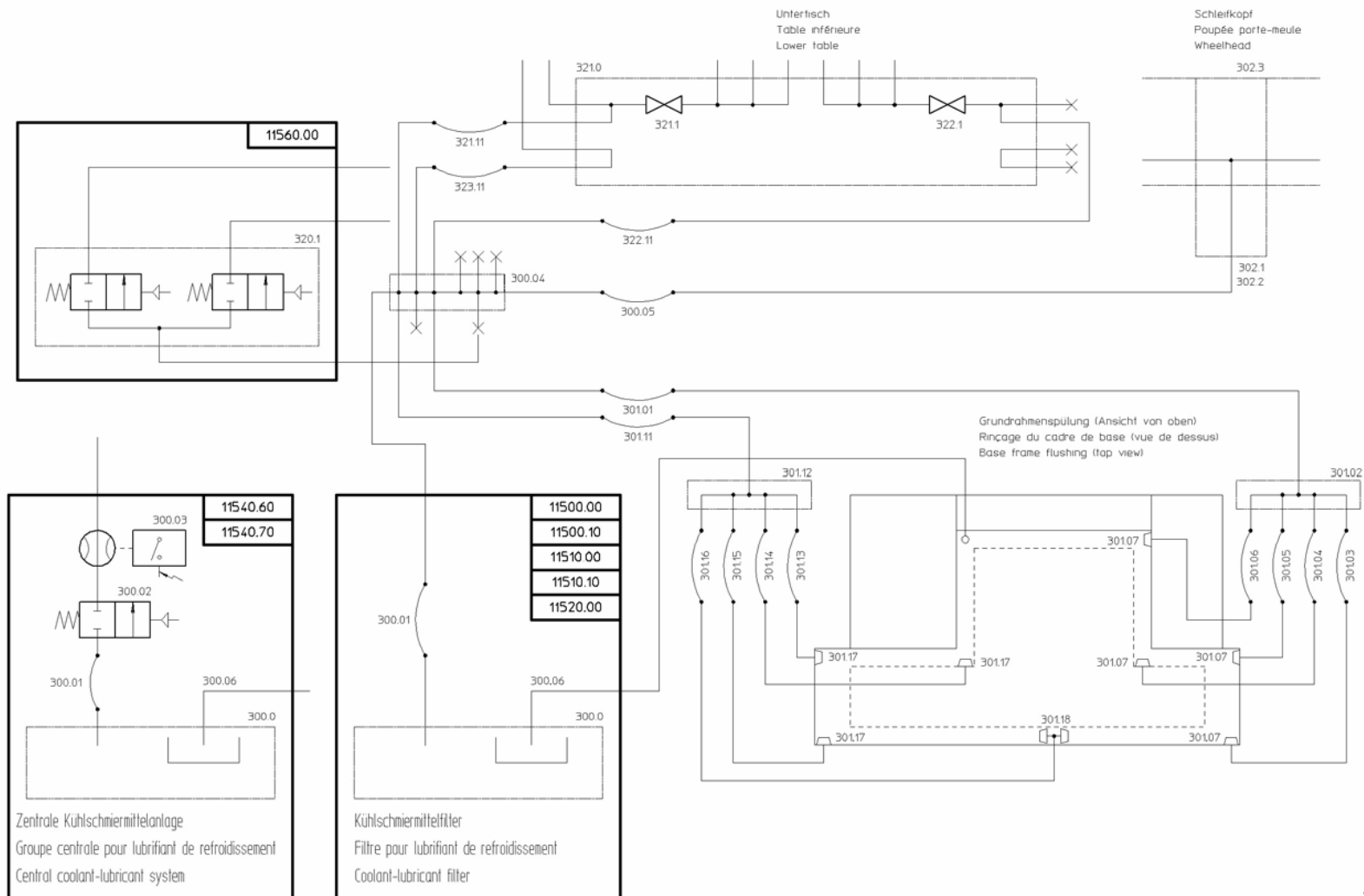

293296-1/4

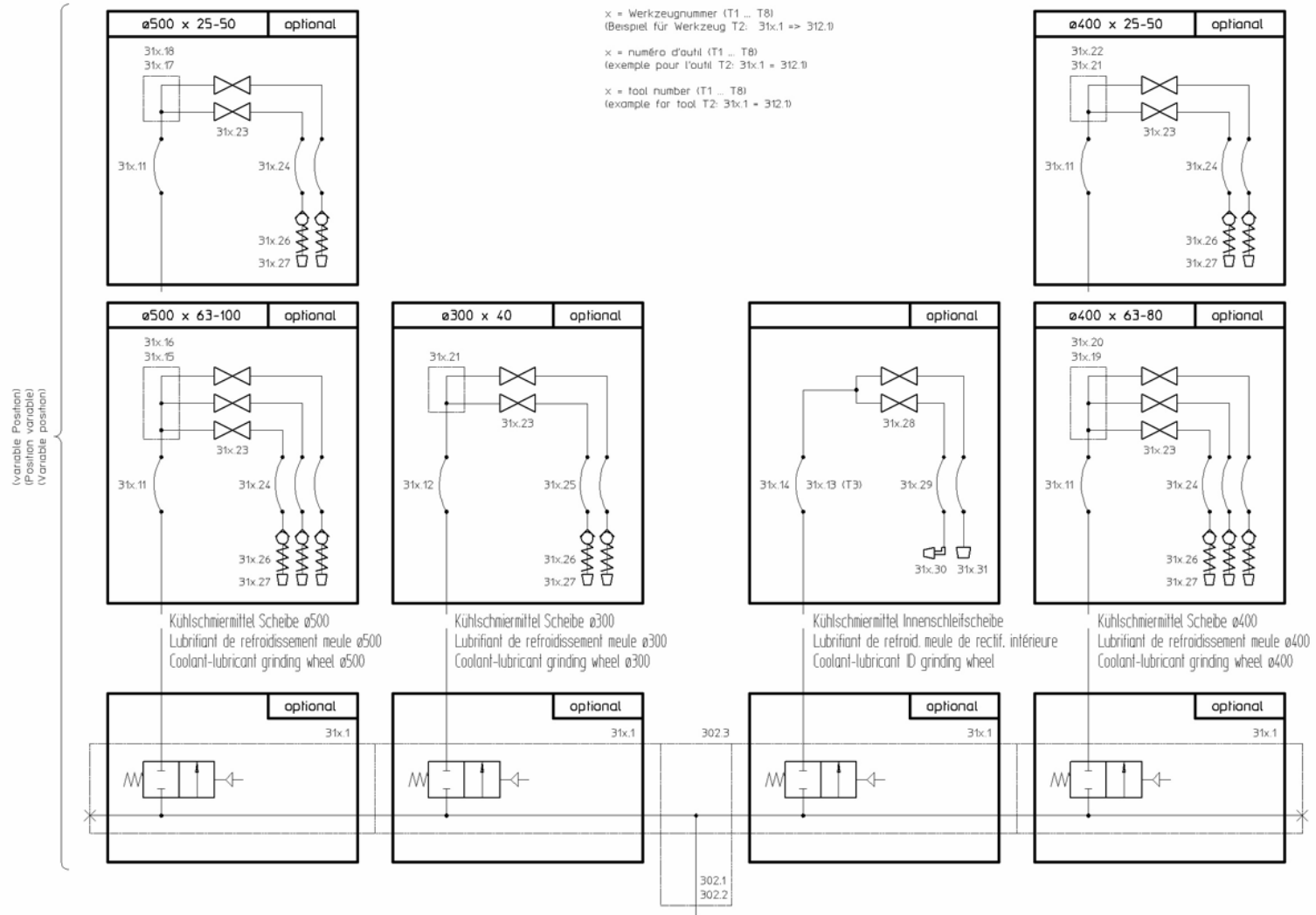

293296-2/4

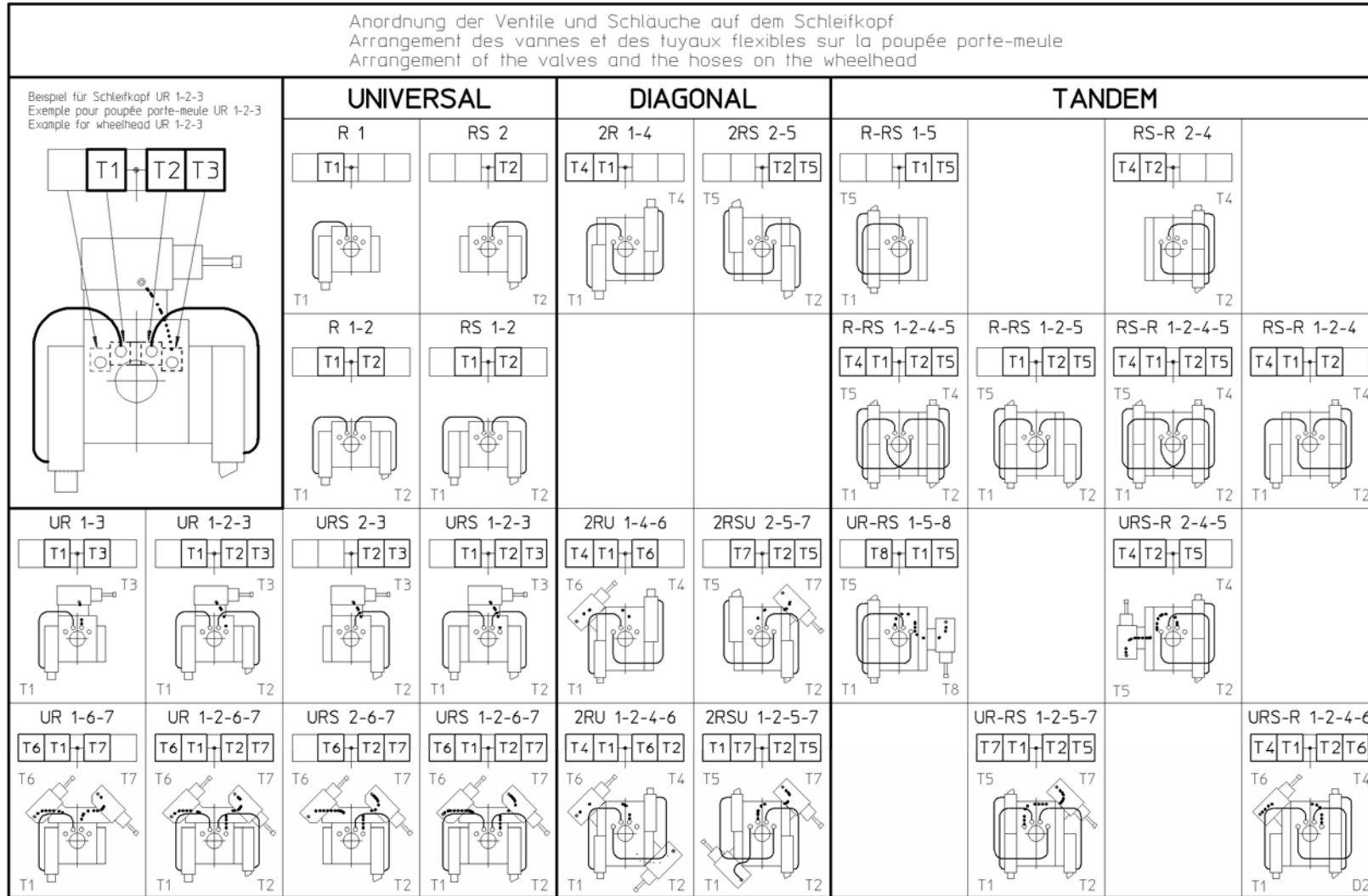

293296-3/4

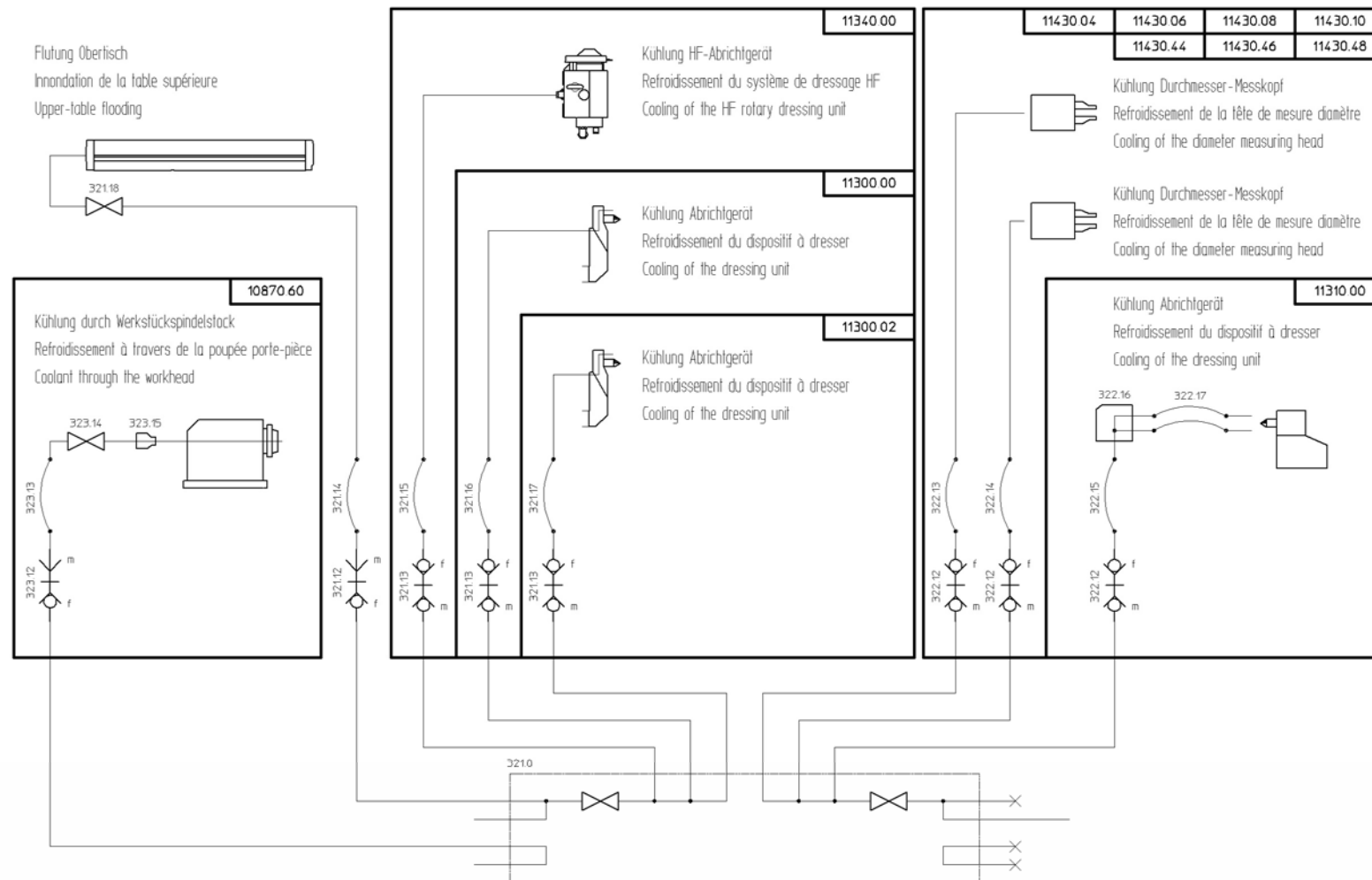

293296-4/4

8 Schmierschema HF- Innenschleifspindel / Schéma de lubrification broches de rectification intérieure H.F. / Lubrication diagram HF internal grinding spindle

Position Rep. Item	Bezeichnung	Désignation	Designation of part	Lieferant Fournisseur Supplier	Bestell-Nr. Référence Order no.	Ident.-Nr. No. d'ident. ID-no.
MFV-INNENSCHLEIFSPINDEL / BROCHES DE RECTIFICATION INTÉRIEURE MFV / MFV INTERNAL GRINDING SPINDLE						
040.1	2X 3/2-WEGEVENTIL GR. 02	2X DISTRIBUTEUR 3/2 VOIES	2X 3/2-DIRECTIONAL CONTROL VALVE	BOSCH	0 820 037 102	145404
040.11	SCHLAUCHLEITUNG Ø 8/6 L=0,3 M	TUYAU FLEXIBLE Ø 8/6 L=0,3 M	HOSE Ø 8/6 L=0,3 M	TRIGRESS	PUR-1198A/8X6	150709
040.12	SCHALLDÄMPFER G1/8"	SILENCIEUX G1/8"	SOUND ABSORBER G1/8"	BOSCH	1 827 000 000	118987
040.13	SCHALLDÄMPFER G1/8"	SILENCIEUX G1/8"	SOUND ABSORBER G1/8"	BOSCH	1 827 000 000	118987
040.2	FILTER-DRUCKREGLER NLI	MANOSTAT FILTRE NLI	FILTER PRESSURE REGULATOR NLI	BOSCH	0 821 300 758	
040.21	FEINFILTER NLI	FILTRE FIN NLI	FINE RILTER NLI	BOSCH	0 821 303 718	
040.22	SCHLAUCHLEITUNG Ø 10/7 L=3,4 M	TUYAU FLEXIBLE Ø 10/7 L=3,4 M	HOSE Ø 10/7 L=3,4 M	TRIGRESS	PUR-1198A/10X7	150710
040.23	SCHLAUCHLEITUNG Ø 10/7 L=0,3 M	TUYAU FLEXIBLE Ø 10/7 L=0,3 M	HOSE Ø 10/7 L=0,3 M	TRIGRESS	PUR-1198A/10X7	150710
040.24	SCHLAUCHLEITUNG Ø 8/6 L=0,8 M	TUYAU FLEXIBLE Ø 8/6 L=0,8 M	HOSE Ø 8/6 L=0,8 M	TRIGRESS	PUR-1198A/8X6	150709
040.3	MIKROPUMPENAGGREGAT 2-FACH	GROUPE POMPE 2-VOIES	MICRO PUMP UNIT 2 WAYS	ILC		153996
040.31	SCHLAUCHLEITUNG Ø 6/4 L=0,3 M	TUYAU FLEXIBLE Ø 6/4 L = 0,3 M	HOSE Ø 6/4 L = 0,3 M	TRIGRESS	PUR-1198A/6X4	150708
040.32	SCHLAUCHLEITUNG Ø 6/4 L=0,3 M	TUYAU FLEXIBLE Ø 6/4 L = 0,3 M	HOSE Ø 6/4 L = 0,3 M	TRIGRESS	PUR-1198A/6X4	150708
040.33	SCHLAUCHLEITUNG Ø 6/4 L=4,5 M	TUYAU FLEXIBLE Ø 6/4 L = 4,5 M	HOSE Ø 6/4 L = 4,5 M	TECALTO	TTF 6X1	105361
040.34	SCHLAUCHLEITUNG Ø 6/4 L=4,5 M	TUYAU FLEXIBLE Ø 6/4 L = 4,5 M	HOSE Ø 6/4 L = 4,5 M	TECALTO	TTF 6X1	105361
041.1	2X 3/2-WEGEVENTIL GR. 02	2X DISTRIBUTEUR 3/2 VOIES	2X 3/2-DIRECTIONAL CONTROL VALVE	BOSCH	0 820 037 102	145404
041.11	SCHLAUCHLEITUNG Ø 8/6 L=0,5 M	TUYAU FLEXIBLE Ø 8/6 L = 0,5 M	HOSE Ø 8/6 L = 0,5 M	TRIGRESS	PUR-1198A/8X6	150709
041.12	SCHALLDÄMPFER G1/8"	SILENCIEUX G1/8"	SOUND ABSORBER G1/8"	BOSCH	1 827 000 000	118987
041.13	SCHALLDÄMPFER G1/8"	SILENCIEUX G1/8"	SOUND ABSORBER G1/8"	BOSCH	1 827 000 000	118987
041.2	MIKROPUMPENAGGREGAT 2-FACH	GROUPE POMPE 2-VOIES	MICRO PUMP UNIT 2 WAYS	ILC		153996
041.21	SCHLAUCHLEITUNG Ø 6/4 L=0,3 M	TUYAU FLEXIBLE Ø 6/4 L = 0,3 M	HOSE Ø 6/4 L = 0,3 M	TRIGRESS	PUR-1198A/6X4	150708
041.22	SCHLAUCHLEITUNG Ø 6/4 L=0,3 M	TUYAU FLEXIBLE Ø 6/4 L = 0,3 M	HOSE Ø 6/4 L = 0,3 M	TRIGRESS	PUR-1198A/6X4	150708
041.23	SCHLAUCHLEITUNG Ø 6/4 L=4,5 M	TUYAU FLEXIBLE Ø 6/4 L = 4,5 M	HOSE Ø 6/4 L = 4,5 M	TECALTO	TTF 6X1	105361
041.24	SCHLAUCHLEITUNG Ø 6/4 L=4,5 M	TUYAU FLEXIBLE Ø 6/4 L = 4,5 M	HOSE Ø 6/4 L = 4,5 M	TECALTO	TTF 6X1	105361
041.3	ABSPERRVENTIL NL2	SOUPAPE D'ARRÊT NL2	SHUT-OFF VALVE NL2	BOSCH	0 821 300 922	156698
041.31	SCHALLDÄMPFER	SILENCIEUX	SOUND ABSORBER	BOSCH	1 827 000 01	119500
041.32	SCHLAUCHLEITUNG Ø 6/4 L=0,32 M	TUYAU FLEXIBLE Ø 6/4 L = 0,32 M	HOSE Ø 6/4 L = 0,32 M	TRIGRESS	PUR-1198A/6/4	150708
045.1	ÖLBEHÄLTER MIT FILTER 5 µM	RÉSERVOIR D'HUILE AVEC FILTRE 5 µM	OIL TANK WITH FILTRE 5 µM	ILC		153994
045.11	SCHLAUCHLEITUNG Ø 8/5,5 L=0,2 M	TUYAU FLEXIBLE Ø 8/5,5 L = 0,2 M	HOSE Ø 8/5,5 L = 0,2 M	LEGRIS	1025U08 00 5.5/8	121638

Position Rep. Item	Bezeichnung	Désignation	Designation of part	Lieferant Fournisseur Supplier	Bestell-Nr. Référence Order no.	Ident.-Nr. No. d'ident. ID-no.
MFM-INNENSCHLEIFSPINDEL / BROCHES DE RECTIFICATION INTÉRIEURE MFM / MFM INTERNAL GRINDING SPINDLE						
040.1	2X 3/2-WEGEVENTIL GR 02	2X DISTRIBUTEUR 3/2 VOIES	2X 3/2-DIRECTIONAL CONTROL VALVE	BOSCH	0 820 037 102	145404
040.11	SCHLAUCHLEITUNG ø 8/6 L=0,3 M	TUYAU FLEXIBLE ø 8/6 L = 0,3 M	HOSE ø 8/6 L = 0,3 M	TRIGRESS	PUR-1198A/8X6	150709
040.12	SCHALLDÄMPFER G1/8"	SILENCIEUX G1/8"	SOUND ABSORBER G1/8"	BOSCH	1 827 000 000	118987
040.13	SCHALLDÄMPFER G1/8"	SILENCIEUX G1/8"	SOUND ABSORBER G1/8"	BOSCH	1 827 000 000	118987
040.2	FILTER-DRUCKREGLER NLI	MANOSTAT FILTRE NLI	FILTER PRESSURE REGULATOR NLI	BOSCH	0 821 300 758	-
040.21	FEINFILTER NLI	FILTRE FIN NLI	FINE FILTER NLI	BOSCH	0 821 303 718	-
040.22	SCHLAUCHLEITUNG ø 10/7 L=3,4 M	TUYAU FLEXIBLE ø 10/7 L=3,4 M	HOSE ø 10/7 L=3,4 M	TRIGRESS	PUR-1198A/10X7	150710
040.23	SCHLAUCHLEITUNG ø 10/7 L=0,3 M	TUYAU FLEXIBLE ø 10/7 L=0,3 M	HOSE ø 10/7 L=0,3 M	TRIGRESS	PUR-1198A/10X7	150710
040.24	SCHLAUCHLEITUNG ø 8/6 L=0,8 M	TUYAU FLEXIBLE ø 8/6 L = 0,8 M	HOSE ø 8/6 L = 0,8 M	TRIGRESS	PUR-1198A/8X6	150709
040.3	MIKROPUMPENAGGREGAT 4-FACH	GROUPE POMPE 2-VOIES	MICRO PUMP UNIT 2 WAYS	ILC		153995
040.31	SCHLAUCHLEITUNG ø 6/4 L=0,3 M	TUYAU FLEXIBLE ø 6/4 L = 0,3 M	HOSE ø 6/4 L = 0,3 M	TRIGRESS	PUR-1198A/6/4	150708
040.32	SCHLAUCHLEITUNG ø 6/4 L=0,3 M	TUYAU FLEXIBLE ø 6/4 L = 0,3 M	HOSE ø 6/4 L = 0,3 M	TRIGRESS	PUR-1198A/6/4	150708
040.33	SCHLAUCHLEITUNG ø 6/4 L=4,5 M	TUYAU FLEXIBLE ø 6/4 L = 4,5 M	HOSE ø 6/4 L = 4,5 M	TECALTO	TTF 6X1	105361
040.34	SCHLAUCHLEITUNG ø 6/4 L=4,5 M	TUYAU FLEXIBLE ø 6/4 L = 4,5 M	HOSE ø 6/4 L = 4,5 M	TECALTO	TTF 6X1	105361
040.35	SCHLAUCHLEITUNG ø 6/4 L=4,5 M	TUYAU FLEXIBLE ø 6/4 L = 4,5 M	HOSE ø 6/4 L = 4,5 M	TECALTO	TTF 6X1	105361
040.36	SCHLAUCHLEITUNG ø 6/4 L=4,5 M	TUYAU FLEXIBLE ø 6/4 L = 4,5 M	HOSE ø 6/4 L = 4,5 M	TECALTO	TTF 6X1	105361
041.1	2X 3/2-WEGEVENTIL	2X DISTRIBUTEUR 3/2 VOIES	2X 3/2-DIRECTIONAL CONTROL VALVE	BOSCH	0 820 037 102	145404
041.11	SCHLAUCHLEITUNG ø 8/6 L=0,5 M	TUYAU FLEXIBLE ø 8/6 L = 0,5 M	HOSE ø 8/6 L = 0,5 M	TRIGRESS	PUR-1198A/8X6	150709
041.12	SCHALLDÄMPFER G1/8"	SILENCIEUX G1/8"	SOUND ABSORBER G1/8"	BOSCH	1 827 000 000	118987
041.13	SCHALLDÄMPFER G1/8"	SILENCIEUX G1/8"	SOUND ABSORBER G1/8"	BOSCH	1 827 000 000	118987
041.2	MIKROPUMPENAGGREGAT 4-FACH	GROUPE POMPE 4-VOIES	MICRO PUMP UNIT 4 WAYS	ILC		153995
041.21	SCHLAUCHLEITUNG ø 6/4 L=0,3 M	TUYAU FLEXIBLE ø 6/4 L = 0,3 M	HOSE ø 6/4 L = 0,3 M	TRIGRESS	PUR-1198A/6/4	150708
041.22	SCHLAUCHLEITUNG ø 6/4 L=0,3 M	TUYAU FLEXIBLE ø 6/4 L = 0,3 M	HOSE ø 6/4 L = 0,3 M	TRIGRESS	PUR-1198A/6/4	150708
041.23	SCHLAUCHLEITUNG ø 6/4 L=4,5 M	TUYAU FLEXIBLE ø 6/4 L = 4,5 M	HOSE ø 6/4 L = 4,5 M	TECALTO	TTF 6X1	105361
041.24	SCHLAUCHLEITUNG ø 6/4 L=4,5 M	TUYAU FLEXIBLE ø 6/4 L = 4,5 M	HOSE ø 6/4 L = 4,5 M	TECALTO	TTF 6X1	105361
041.25	SCHLAUCHLEITUNG ø 6/4 L=4,5 M	TUYAU FLEXIBLE ø 6/4 L = 4,5 M	HOSE ø 6/4 L = 4,5 M	TECALTO	TTF 6X1	105361
041.26	SCHLAUCHLEITUNG ø 6/4 L=4,5 M	TUYAU FLEXIBLE ø 6/4 L = 4,5 M	HOSE ø 6/4 L = 4,5 M	TECALTO	TTF 6X1	105361
041.3	ABSPERRVENTIL NL2	SOUPAPE D'ARRÊT NL2	SHUT-OFF VALVE NL2	BOSCH	0 821 300 922	156698
041.31	SCHALLDÄMPFER	SILENCIEUX	SOUND ABSORBER	BOSCH	1 827 000 01	119500
041.32	SCHLAUCHLEITUNG ø 6/4 L=0,32 M	TUYAU FLEXIBLE ø 6/4 L = 0,32 M	HOSE ø 6/4 L = 0,32 M	TRIGRESS	PUR-1198A/6/4	150708

Position Rep. Item	Bezeichnung	Désignation	Designation of part	Lieferant Fournisseur Supplier	Bestell-Nr. Référence Order no.	Ident.-Nr. No. d'ident. ID-no.
042.1	DROSSELRÜCKSCHLAGVENTIL	SOUPAPE D'ÉTRANGLEMENT	ONE WAY RESTRICTOR VALVE	TRIGRESS	DRV55 2505 1/8"	133958
042.1.1	SCHLAUCHLEITUNG Ø 6/4 L=4,5 M	TUYAU FLEXIBLE Ø 6/4 L = 4,5 M	HOSE Ø 6/4 L = 4,5 M	TRIGRESS	PUR-1198A/6/4	150708
043.1	DROSSELRÜCKSCHLAGVENTIL	SOUPAPE D'ÉTRANGLEMENT	ONE WAY RESTRICTOR VALVE	TRIGRESS	DRV55 2505 1/8"	133958
043.1.1	SCHLAUCHLEITUNG Ø 6/4 L=4,5 M	TUYAU FLEXIBLE Ø 6/4 L = 4,5 M	HOSE Ø 6/4 L = 4,5 M	TRIGRESS	PUR-1198A/6/4	150708
044.1	ÖLABSCHEIDER MIT SCHALLDÄMPFUNG 1/2"	SEPARATEUR D'HUILE AVEC ISOLATION PHONIQUE 1/2"	OIL SEPARATOR WITH SILENCER 1/2"	BOSCH	HE00751353	153997
044.1.1	SCHLAUCHLEITUNG Ø 8/5,5 L=4,0 M	TUYAU FLEXIBLE Ø 8/5,5 L = 4,0 M	HOSE Ø 8/5,5 L = 4,0 M	LEGRIS	1025U08 00 5.5/8	121638
044.1.2	SCHLAUCHLEITUNG Ø 8/5,5 L=0,8 M	TUYAU FLEXIBLE Ø 8/5,5 L = 0,8 M	HOSE Ø 8/5,5 L = 0,8 M	LEGRIS	1025U08 00 5.5/8	121638
044.1.3	SCHLAUCHLEITUNG Ø ø 8/5,5 L=4,0 M	TUYAU FLEXIBLE Ø 8/5,5 L = 4,0 M	HOSE Ø 8/5,5 L = 4,0 M	LEGRIS	1025U08 00 5.5/8	121638
045.1	ÖLBEHÄLTER MIT FILTER 5 µM	RÉSERVOIR D'HUILE AVEC FILTRE 5 µM	OIL TANK WITH FILTRE 5 µM	ILC		153994
045.1.1	SCHLAUCHLEITUNG Ø 8/5,5 L=0,2 M	TUYAU FLEXIBLE Ø 8/5,5 L = 0,2 M	HOSE Ø 8/5,5 L = 0,2 M	LEGRIS	1025U08 00 5.5/8	121638
045.1.2	SCHLAUCHLEITUNG Ø 8/5,5 L=0,35 M	TUYAU FLEXIBLE Ø Ø 8/5,5 L = 0,35 M	HOSE Ø 8/5,5 L = 0,35 M	LEGRIS	1025U08 00 5.5/8	121638

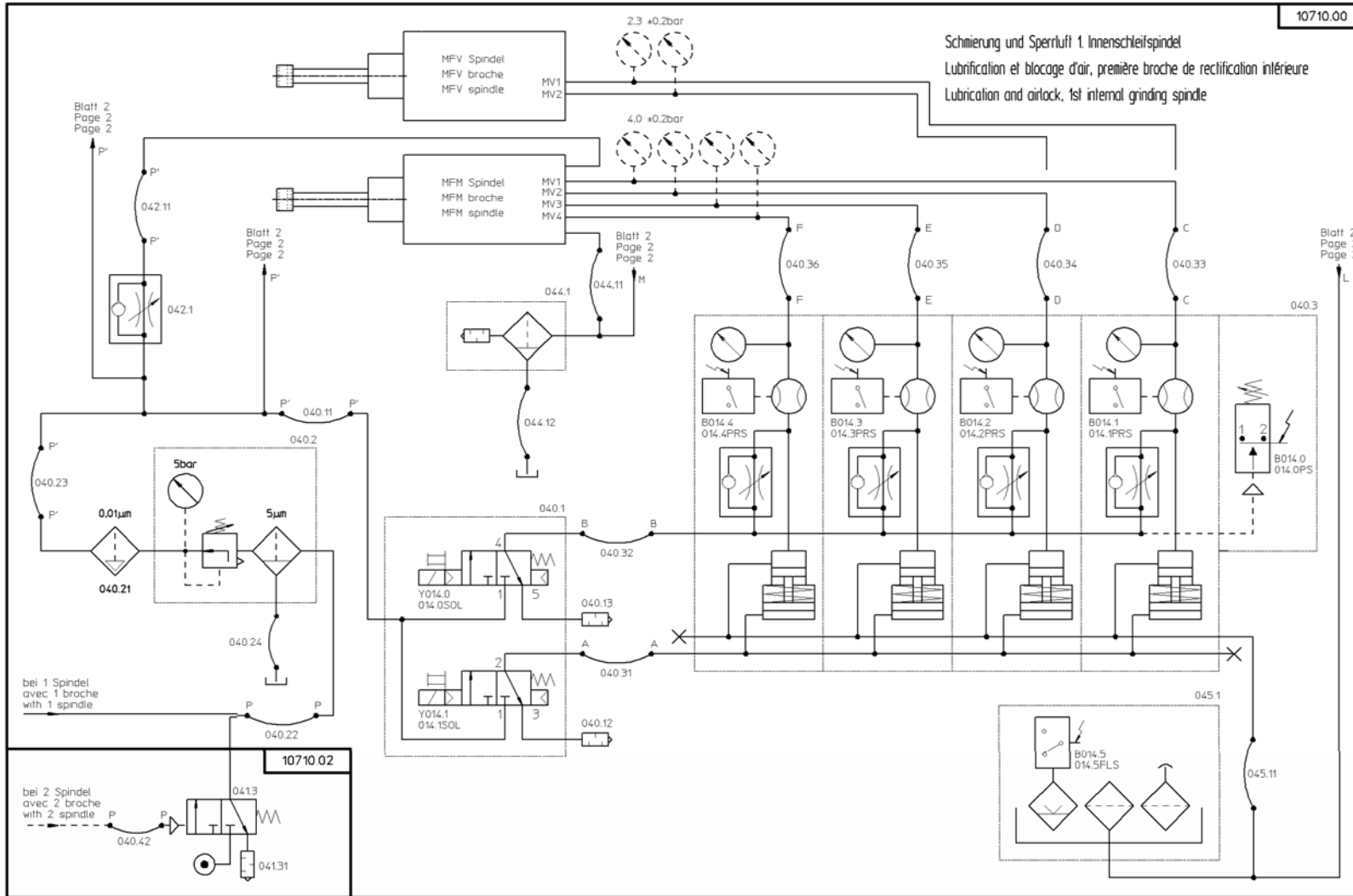

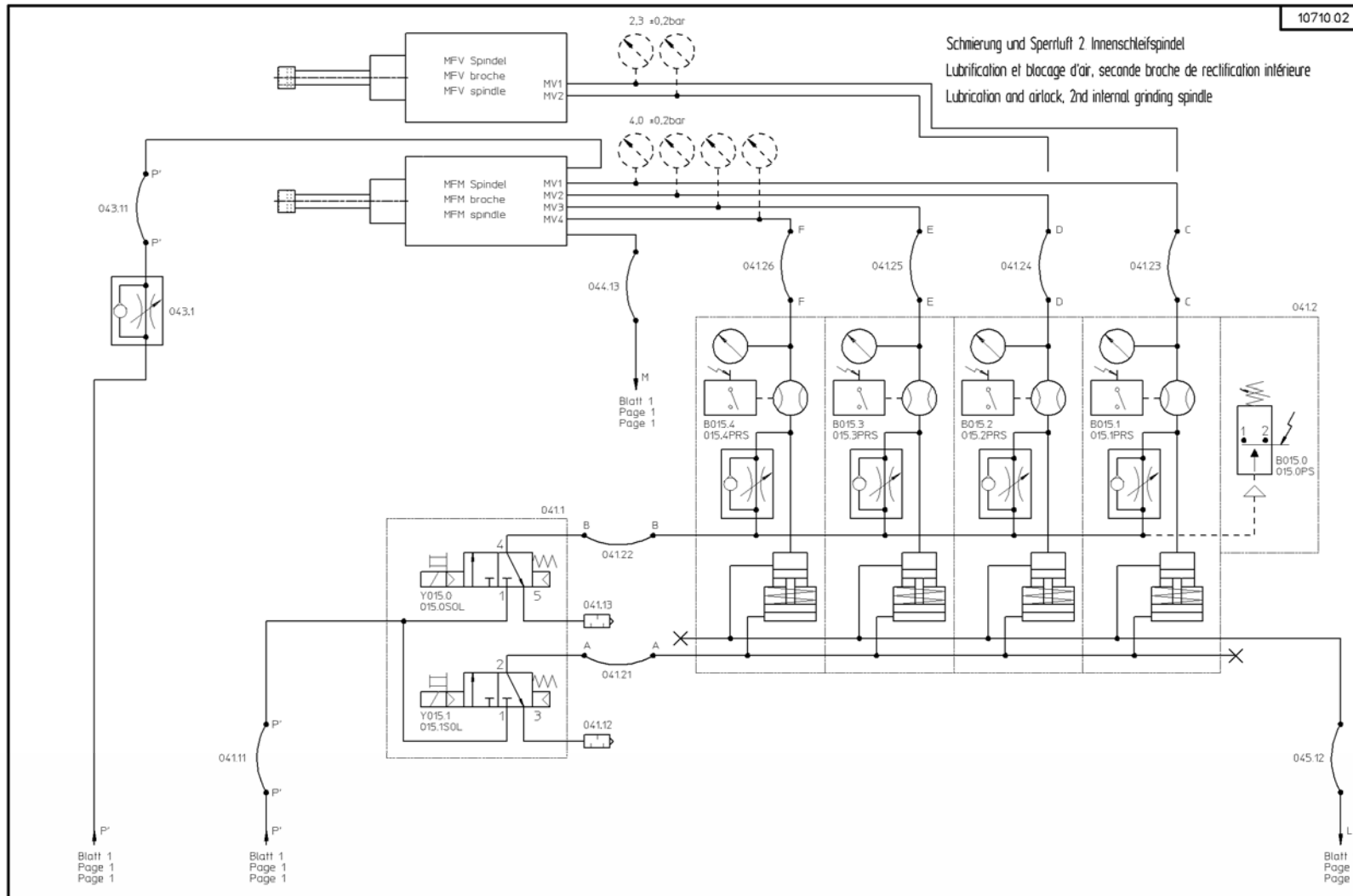

293350-2/2

9 Schmieranleitung / Instructions de graissage / Lubrication instructions

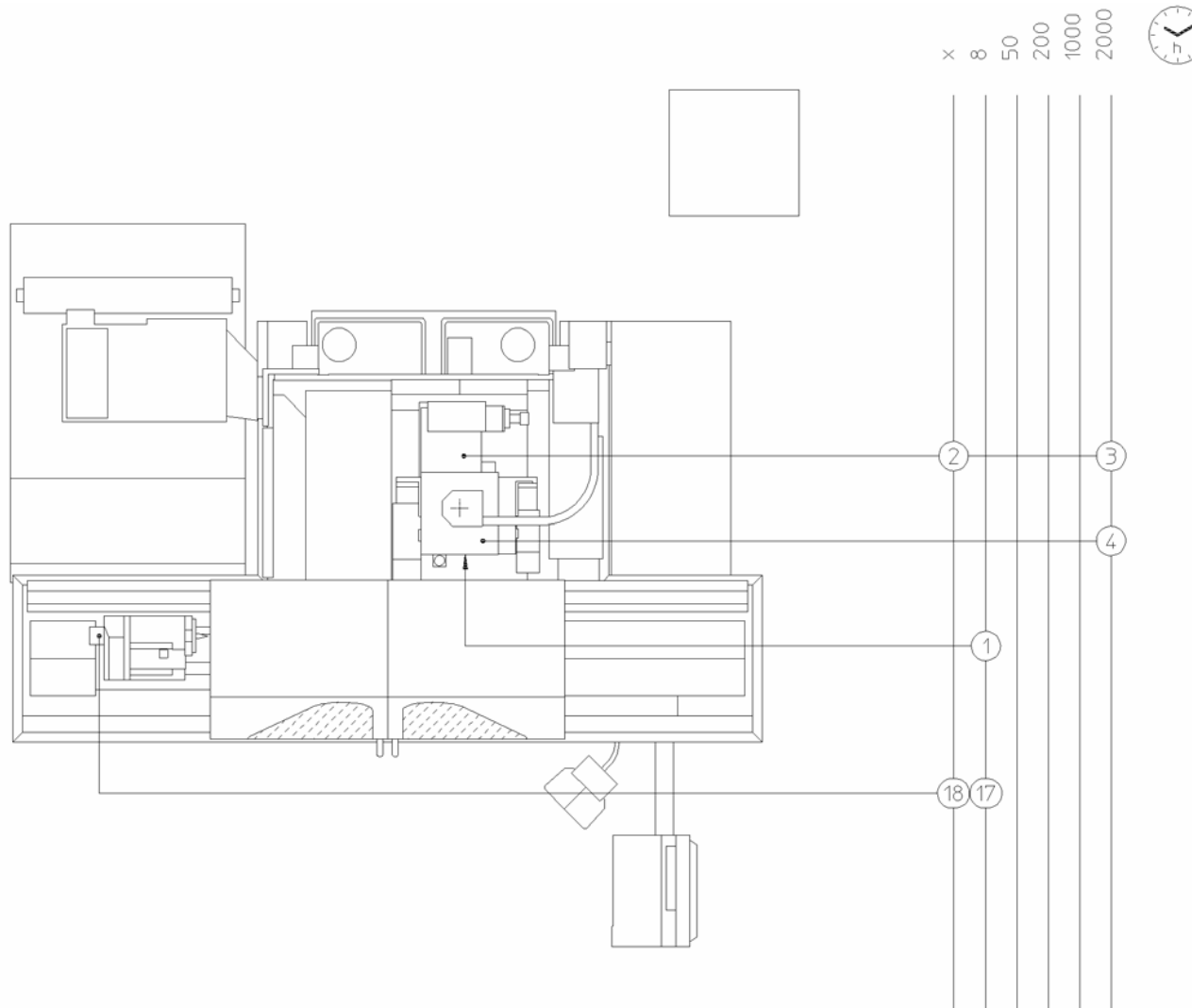

293329-1/2

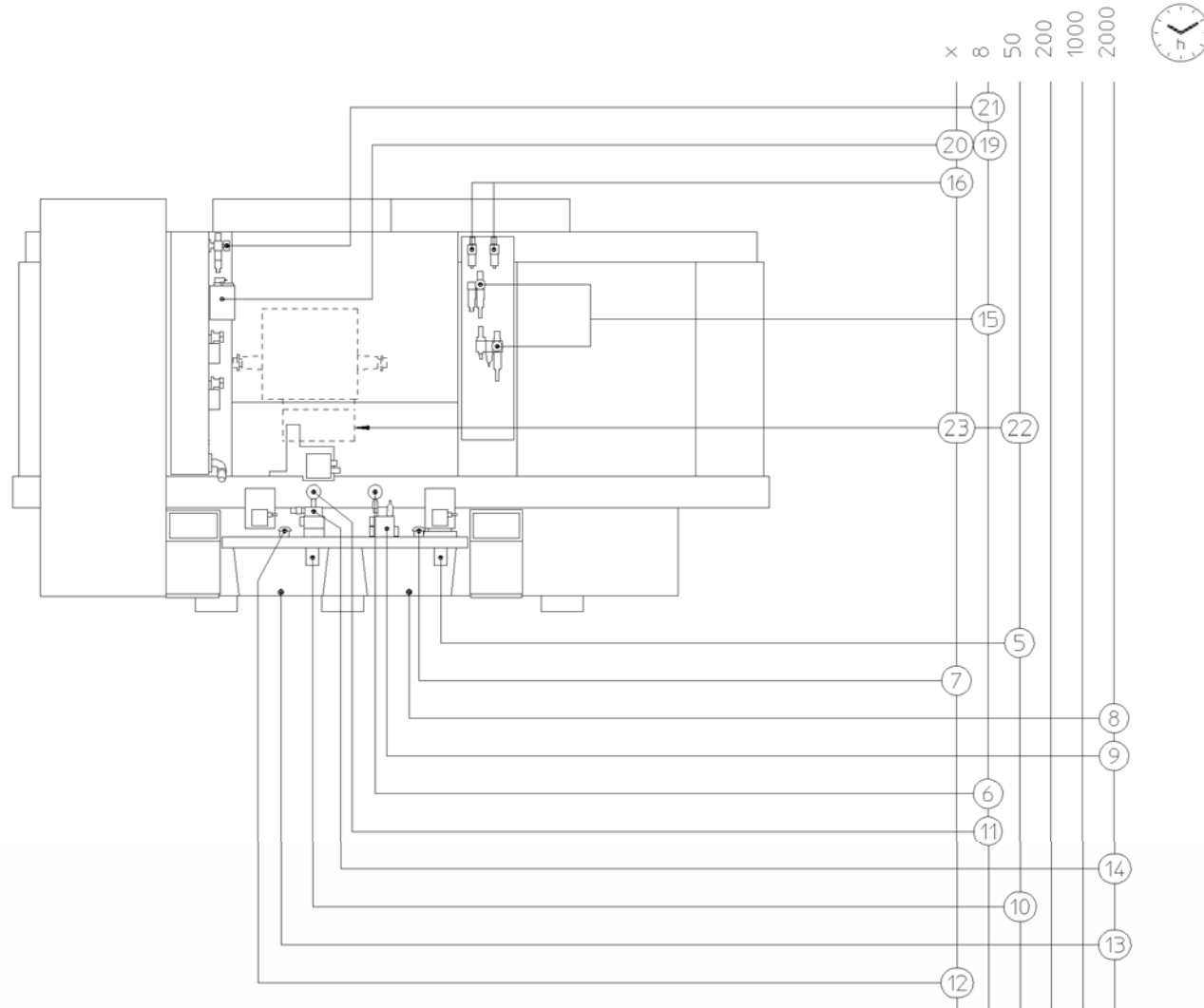

293329-2/2

Maschinenteile Organes de machine Machine parts	Schleifspindel Broche porte-meule Grinding spindle				Hydraulikaggregat Système hydraulique Hydraulic assembly					Hydrostatikaggregat Système hydrostatique Hydrostatic assembly					Pneumatik Système pneumatique Pneumatic system		Optionen / Options / Options							
																	Kraft-Spann- einrichtung Vérin de serrage Power collet tube		Innenschleifspindel Broche de rectific. int. ID grinding spindle			B-Achse / Drehteil mit autom. Indexierung Axe B / Plateau d'index. autom. B axis / Swiv. system with auto. indexing		
Position Pièce Item	1	2	3	4	5	6	7	8	9	10	11	12	13	14	15	16	17	18	19	20	21	22	23	
Symbol Symbole Symbol																								
Prüfen Contrôler Check	 8h				 50h	 8h				 50h	 8h				 8h		 8h		 8h		 8h	 50h		
Auffüllen nach Bedarf Remplir selon besoin Refill if necessary		•					•					•				•		•		•				
Reinigen und ersetzen Nettoyer ou remplacer Clean or replace				 2000h					 2000h					 2000h										
Austauschen Echanger Exchange			 2000h					 2000h					 2000h											
Behälterkapazität I Capacité de récipient I Capacity of tank I	Universal 4				25					25					0,04		0,05		2,2			0,6		
	Tandem/Diagonal 5																							
Schmierstoffe Lubrifiants Lubricants	ISO 3498 FC 2	FC 5	FC 3		HM 68									CB 32				HM 46			VG 150			
	DIN 8659 CL 2	CL 5	CL 3		HLP 68									CL 32				HLP 46			PG 150			
Viskosität Viscosité Viscosity	1,94	4,8	4,7	3,2	64	68	68	64	68	30	32	32	30						46			140	150	150
Bezeichnung Désignation Designation	Velocite 3	Energol HP 5	Morlina Oel 5	Plus 3	Mobil DTE 26	Energol HLP 68	Tellus Oil T 68	Nuto H 68	Plus 68	Mobil DTE 24	Energol HLP-D 32	Plus 32	Nuto H 32	Energol HLP-D 46	Nuto H 46	Mobil DTE 25	Corex HLP-D 46	Tellus Oil 46	Vactra 3	Maccurat 150	Topside A 16-44			
Hersteller Producteur Manufacturer	Mobil	BP	Shell	Aseol	Mobil	BP	Shell	Esso	Aseol	Mobil	BP	Aseol	Esso	BP	Esso	Mobil	Motorex	Shell	Mobil	BP	Aseol			